

STUDENT HANDBOOK

Undergraduate Programme

2020-2021



MESSAGE FROM THE VICE CHANCELLOR

A warm welcome to LUMS—your home to learn, grow and give back to every part of Pakistan that you come from. The diversity within LUMS is our greatest strength where differences in language, race, class, religious affiliation, or gender are celebrated. This diversity will enrich your learning just as much as what you will learn from your instructors' expertise.



Transitioning to university life is challenging both in terms of higher academic standards (more work!) and self-sufficiency (individual responsibility). So, here are 3 practical tips to immerse yourself in the LUMS experience. First, read your course outlines and create a schedule that shows due dates for ALL of your assignments, tests and exams for the semester. This will give you a sense of your overall workload. Second, make it a priority to set aside the time that you need to do weekly course work to meet the deadlines. Third, it is easy to procrastinate and fall behind – which is the number one reason for distress and poor results. Instead, be proactive, find peers, study groups, and teachers who will help you from the get-go. Trust me, support is what the LUMS family is all about.

You will start like no other cohort has! The global pandemic has forced everyone to sharpen their online skill sets which are expected from 21st century graduates. The online experience comes with as many opportunities as it does challenges which we are learning to navigate. And when you look back at your learning at LUMS you will be glad to have experienced the best of what both online and in class courses offer in helping you to better prepare for your career aspirations. I urge you to participate in all of the orientation activities and especially the “Welcome to My Class” sessions which will give you a sample of what, and how you will learn online. Online and blended learning is here to stay at LUMS and will be complemented by your classroom and campus experiences.

Your most memorable learning will occur outside the classrooms. It might be during the times you are immersed in one of the many LUMS Societies, in serving as a member of the Student Council, in service learning to support the disadvantaged, or for that matter, participating any number of sports and extra-curricular events. The key is to get involved from the start!

I look forward to welcoming you virtually and in person. Best of luck to each and every one of you!

Dr Arshad Ahmad
Vice Chancellor, LUMS

DISCLAIMER

This catalogue represents the most accurate information available at the time of publication in August 2020. The University reserves the right to correct, or otherwise change any information without prior notice at its sole discretion.

The most updated version is available at the Office of the Registrar portal:

<http://portal.lums.edu.pk/RegistrarOffice> > Documents to Download > Student Handbooks and Policies

Lahore University of Management Sciences

Sector U, D.H.A, Lahore Cantt.

Lahore, 54792, Pakistan.

Tel: +92 42 3560 8000

Website: www.lums.edu.pk

Office of the Registrar Contact Information:

Portal: <http://portal.lums.edu.pk/RegistrarOffice>

Email: helpdeskro@lums.edu.pk

Vision

LUMS is Pakistan’s leading research-intensive university, excelling in teaching and driven by a philosophy of learning without borders. LUMS provides an integrated curriculum, uniting disciplines to focus on solving the grand challenges of South Asia and beyond.

Mission

LUMS aspires to achieve excellence in national and international leadership through unparalleled teaching and research, holistic undergraduate education, and civic engagement to serve the critical needs of society.

It seeks to accomplish this mission as a unified institution with cutting-edge research, a modern and rigorous curriculum and socially responsible outreach to the nation and region.

Core Values

Merit

LUMS adheres to merit as the sole criteria in its decision making. This applies to all aspects of its operations, from selection of faculty and staff, to admission and evaluation of students.

Academic Freedom

We believe in the pursuit of knowledge and value the freedom to explore different disciplines without borders. We respect the right of our community members to express their ideas and encourage freedom of thought.

Integrity

Integrity is the cornerstone of our philosophy and an integral part of all our interactions. We hold ourselves to the highest standards and inculcate a culture of ethical conduct, trust, respect, fairness, and develop the same commitment in our students to ensure that they are responsible global citizens with strong character.

Diversity

Our diversity is our hallmark feature that enriches our community’s experience. This is evident in the variety of programmes, disciplines and the different viewpoints, ethnicities and minorities represented on campus. Our exchange programmes and multicultural platform enables our students to embrace diversity and develop a broader perspective on collaboration.

Tolerance

We are committed to creating a positive and safe environment that thrives on freedom of thought. Our community members are encouraged to express unique point of views and engage in polite and respectful exchange of ideas and opinions.

Excellence

We strive for excellence in all our activities; from the creation of new knowledge through scholarship and research to utilizing our learnings for the benefit of society.

Non-Profit Status

LUMS is a federally chartered university and is approved as a non-profit organization under section 2(36) of Income Tax Ordinance, 2001 in terms of provisions of Clause 63 of Part IV of Second Schedule to the Ordinance. Any individual or organization making donations to LUMS is entitled to a tax credit under section 61 of Income Tax Ordinance, 2001. Moreover, the University has been granted exemption from the levy of income tax under Section 159 of the Ordinance, and thus, tax is not deductible on payments made to the University.

TABLE OF CONTENTS

ABOUT LUMS	01
SCHOOLS AT LUMS	03
Suleman Dawood School of Business.....	03
Mushtaq Ahmad Gurmani School of Humanities and Social Sciences	04
Syed Babar Ali School of Science and Engineering	06
Shaikh Ahmad Hassan School of Law	08
Syed Ahsan Ali & Syed Maratib Ali School of Education	09
UNDERGRADUATE PROGRAMME POLICIES AND REGULATIONS	10
1. Academic Year*	11
2. Student Categories**	11
3. Undergraduate Programme Policies.....	11
3.1. Undergraduate Programme Duration and Structure	12
3.2. University Core.....	13
3.3. University Distribution Requirements.....	13
4. Registration of Courses.....	15
4.1. Course Descriptions	15
4.2. Course Outlines.....	15
4.3. Online Course Evaluations by Students.....	15
5. Phases of Course Registration	16
5.1. Enrollment Phase I	16
5.2. Enrollment Phase II	16
6. Add/Drop and Withdrawal Periods for Regular Courses and Directed Coursework	16
6.1. Add/drop period through Zambeel	16
6.2. Add Only day.....	16
6.3. Add/Drop by approval.....	16
6.4. Drop Only period*	17
6.5. Withdrawal Period	17
6.6. Enrollment Wipeout Process	18
7. Student Status and Course Load.....	18
7.1. Regular Semester	18
7.2. Summer Semester.....	18
8. Directed Course Work (Courses Requiring Exceptional Method of Registration)	19
8.1. Senior Project (SPROJ).....	20
8.2. Independent Study (IS)	21
8.3. Directed Research Project (DRP):	21
8.4. Audit Internship	22
9. Courses that Require a Separate Mention	22

9.1. Remedial Course in Writing & Communication	22
9.2. Language Courses	22
9.3. Waiver for Islamic Studies.....	23
10. Pre-Requisites of Courses	23
11. Cross-listed Courses	23
12. Course Repeat and Replace Policy.....	23
12.1. Policy for Thrice Failure in a Core Course.....	24
13. Course Audit	24
14. Course Cancellation	24
15. Major Declaration and Allocation Process for First year students	24
15.1. SDSB First Year Students Major Declaration	25
15.2. MGSBSS Sophomores Major Declaration.....	25
15.3. SBASSE First Year Students Major Declaration	26
15.4. SAHSOL First Year Student Major Declaration	26
15.5. Change in Major/School.....	26
16. Joint Major	27
17. Double Major.....	27
18. Minor Declaration	28
18.1. Rules for Minors	29
19. Withdrawals	29
19.1. Voluntary Withdrawal from the University and Programme	30
19.2. Semester off from Campus.....	30
19.3. Withdrawal from all courses in a semester	30
19.4. Withdrawal from a course in a semester	31
19.5. Involuntary Withdrawal	31
19.6. Unauthorized Withdrawal	31
20. Transfer Students	32
20.1. Credits for Courses Taken at Institutions under the LUMS Exchange Programme	33
20.2. Credits for Courses Taken by LUMS Students at Other Institutions	34
21. Academic Performance	34
21.1. Student Evaluation	34
21.2. Grading Policy.....	35
21.3. Calculation of Semester GPA	36
21.4. Calculation of Cumulative GPA (CGPA)	36
21.5. Grade Review Policy	37
21.6. Grade Change Policy.....	38
21.7. Course Pass/Fail Policy	38
22. Attendance Policy	39

22.1. BA (Honours)/BS/BSc (Honours) Programmes	39
22.2. B.A.-LLB (Honours) Programme (LL. B Years I, II, and III)	39
23. Examinations	39
24. Make-up Policy for Graded Instruments	39
24.1. Medical Cases.....	41
24.2. Death in the Immediate Family	41
24.3. Extracurricular Activities	41
24.4. Visa/Employment Cases	42
24.5. Weddings, Other Emergencies	42
25. Academic Standing	42
25.1. Academic Warning	42
25.2. Probation and Separation	42
25.3. Readmission upon Separation	44
25.4. After Withdrawal or Separation	46
26. Graduation Tracking	46
26.1. Graduation Audit Form (GAF).....	46
26.2. Other Graduation Clearance Requirements	47
26.3. Graduation Denied	47
26.4. Name on Transcript and Degree.....	47
26.5. Degree before Convocation (DBC)	48
26.6. Award of Regular Degree on the Convocation Day	48
26.7. University Clearance, and Security Refund	48
27. Academic Honours at LUMS	49
27.1. Honours.....	49
27.2. Medals.....	49
27.3. Medals – Specialization (Major)	50
27.4. Undergraduate Semester Wise/End of the Year Academic Recognition	50
28. Important Policies regarding Code of Conduct at LUMS	51
28.1. Some Norms of the University	51
28.2. On-Campus Smoking Policy	52
28.3. Illegal Drugs and Alcoholic Beverages	53
29. Sexual Harassment	53
30. Disciplinary Examinations and Appeals Committee (DEAC)	54
31. Student Disciplinary Committee (DC)	54
31.1. Petition.....	54

31.2. DC Decision Implementation	54
31.3. Assignments	56
31.4. Unprofessional Conduct	56
31.5. What is Plagiarism?	56
31.6. Procedure for Handling Grievances	58
ACADEMIC DEPARTMENTS & PROGRAMME OUTLINES	59
SULEMAN DAWOOD SCHOOL OF BUSINESS (SDSB)	60
The Accounting and Finance (ACF) Programme	62
The Management Science (MGS) Programme	69
Public Management Minor	82
Computational Finance Minor	83
Office of Undergraduate Student Advising SDSB (OUSA - SDSB)	84
MUSHTAQ AHMAD GURMANI SCHOOL OF HUMANITIES AND SOCIAL SCIENCES (MGSHSS)	87
MGSHSS Core Curriculum	88
Department of Humanities and Social Sciences	91
The Anthropology/Sociology Programme	91
The Political Science Programme	94
The History Programme	98
The English Programme	100
Minors in Humanities and Social Sciences	102
Comparative Literary and Cultural Studies (CLCS) Minor	105
Gender and Sexuality Studies (GSS) Minor	106
Department of Economics	108
The Economics Programme	108
The Politics and Economics (Joint Major) Programme	111
The Economics and Mathematics (Joint Major) Programme	113
Economics Minor	115
MGSHSS Major Declaration/Change And Inter-School Transfer Requirements	116
Academic Advising at MGSHSS	117
SYED BABAR ALI SCHOOL OF SCIENCE AND ENGINEERING (SBASSE)	121
Department of Biology	125
Department of Chemistry and Chemical Engineering	129
Department of Computer Science	135
Department of Electrical Engineering	138
Department of Mathematics	143
The Economics and Mathematics (Joint Major) Programme	145
Department of Physics	149
SBASSE Minors	153
Biology Minor	153

Chemistry Minor.....	154
Computer Science Minor.....	155
Mathematics Minor.....	155
Physics Minor.....	156
Academic Advisement at SBASSE.....	157
SHAIKH AHMAD HASSAN SCHOOL OF LAW (SAHSOL).....	158
B.A.-LLB (Honours) Programme.....	159
Academic Advising at SAHSOL.....	166
SYED AHSAN ALI & SYED MARATIB ALI SCHOOL OF EDUCATION (SOE).....	168
SOE Undergraduate Academic Programmes.....	168
ADMINISTRATIVE OFFICES.....	171
Office of the Registrar (RO).....	172
Office of Academic Advising.....	172
Office of Programme Enhancement (OPE).....	173
Office of International Affairs (OIA).....	173
Office of Admissions (OA).....	175
Office of Financial Aid (OFA).....	176
LUMS National Outreach Programme (NOP).....	179
Office of Accessibility And Inclusion (OAI).....	181
Office of Student Affairs (OSA).....	184
Office of Finance.....	205
Office of Advancement.....	209
LUMS Learning Institute (LLI).....	211
Centre for Continuing Education Studies (CES).....	213
The Gad and Birgit Rausing Library.....	214
Information Systems and Technology (IST).....	221
General Administration Services Department (GAS).....	225
Other Facilities Available at LUMS.....	230
USEFUL CONTACTS.....	232
SUBJECT AREAS AND COURSE CODE PREFIX TABLE.....	233
GLOSSARY.....	234

ABOUT LUMS

History

LUMS is a national University, established by sponsors belonging to the country's leading private and public sector corporations. The goal of the sponsors was to develop an institution which would provide rigorous academic and intellectual training and be a feasible alternative to leading universities abroad.

The National Management Foundation (NMF), the sponsoring body of the University was incorporated in November 1984 and was granted a charter by the Government of Pakistan for establishing LUMS, in March 1985, with the president of Pakistan being designated the role of the Chancellor of the University. Through this charter, the University was given the legal right to establish degree -granting programmes.

The Board of Trustees, the policy-making body of the University, comprises leading members of the business community, academia and representatives of the government. The principal functions of the Board are to set broad policy guidelines and to review the operations of the University. The Board of Governors, the sponsors of LUMS, are responsible for raising the necessary funds for the University's operation and maintenance. Many board members are representatives of the business community and form a crucial link between the University and the industry.

In 1986 LUMS launched its Business School with a world-class MBA Programme (the School has been renamed as the Suleman Dawood School of Business). In 1994, LUMS started a BSc (Honours) Programme in Economics and Computer Science. Over subsequent years this evolved to include more specializations. In 2000, the School of Arts and Sciences was formed to oversee the undergraduate programme at LUMS. Later, Master's programmes in Computer Science, Computer Engineering and Economics were added, followed by the launch of doctoral programmes in Computer Science, Computer Engineering and Mathematics. In addition, an Executive MBA programme, a Bachelors programme in Accounting and Finance, and a PhD programme in Management were added to the programmes offered by the Suleman Dawood School of Business. This year, three new programmes, namely, MS in Business and Public Policy, Technology Management and Entrepreneurship, and Healthcare Management and Innovation were introduced. In 2003, a five year, integrated, BA -LL.B degree was added to the list of programmes offered by the School of Arts and Sciences.

As the Programmes and departments expanded, it became apparent that the scope and diversity of the programmes offered by the School of Arts and Sciences demanded more meaningful division and focus. Hence, in 2006, School of Humanities and Social Sciences was established, which was named the School of Humanities, Social Sciences and Law in 2008. In 2012, it was renamed the Mushtaq Ahmad Gurmani School of Humanities and Social Sciences. The School currently oversees the Social Sciences and Economics departments. This year, the School also launched a new minor in Gender and Sexuality Studies. A separate law school, Shaikh Ahmad Hassan School of Law was also announced and is functional now. Syed Babar Ali School of Science and Engineering previously the School of Science and Engineering, was launched in 2008 and comprises the departments of Computer Science, Electrical Engineering, Mathematics, Physics, Chemistry & Chemical Engineering, and Biology. The School offers Undergraduate, Graduate and Doctoral Programmes in these disciplines.

Approved by the Board of Trustees in 2017, the Syed Ahsan Ali and Syed Maratib Ali School of Education (SOE) is now established as the fifth school at the University, offering an MPhil in Education Leadership and Management and a minor in Education.

At LUMS, we believe in education without borders. The Centres and Offices have been created to make way for tangible and lasting solutions to the communities we serve, locally and beyond. Exciting discoveries are made, and new scholarship is created here through a synergistic relationship between theory and practice.

SCHOOLS AT LUMS

Suleman Dawood School of Business

Management education has been offered at LUMS since the university was founded in 1986. The current Suleman Dawood School of Business (SDSB) was instituted following the generous support received over the years by the family of the late Mr. Sul eman Dawood, a prominent entrepreneur and business leader of Pakistan. The case study teaching pedagogy provided a challenging and relevant curriculum for business education that has been advanced by Harvard Business School and the Ivey Business School at Western University. Today, the study programmes at SDSB combine the case study method with other blended learning innovations.

The school closely collaborates with various centres including the Rausing Executive Development Centre (REDC), which offers short executive courses, and the Centre for Business and Society. LUMS maintains a deep relationship with the business community, helping it to keep the curriculum relevant to the needs of business organizations and ensuring that the students and faculty stay exposed to the dynamics of the management world. Business leaders actively interact with both faculty and students through frequent visits, seminars, and as guest speakers, and their perspectives enrich the classroom experience. Additionally, industry linkages are strengthened by the involvement of faculty in teaching and training in the executive development programmes that are attended annually by more than 2,000 senior executives and managers.

The Suleman Dawood School of Business (SDSB) offers a four-year BSc (Honours) degree in the following majors:

- Accounting and Finance
- Management Science

In addition to the above majors, SDSB offers a Minor in the following disciplines:

- Public Management
- Computational Finance

SDSB's vision is to develop ideas and people to shape business and society. It carries out its mission by advancing ethical and thoughtful leadership, influencing practice and policy through knowledge generation and offering a transformational learning experience.

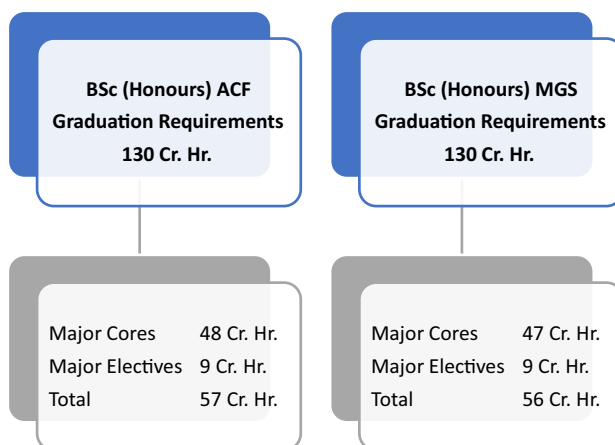

Mushtaq Ahmad Gurmani School of Humanities and Social Sciences

Mushtaq Ahmad Gurmani School of Humanities and Social Sciences (MGSHSS) offers the most innovative programmes for students, along with an invigorating research environment for faculty in the entire South Asian region.

MGSHSS comprises two departments:

- Humanities and Social Sciences, and
- Economics

MGSHSS offers four-year degree programmes in the following majors:

BSc (Honours)

- Anthropology / Sociology
- Economics
- Economics and Mathematics (Joint Major)
- Politics and Economics (Joint Major)
- Political Science

BA (Honours)

- History
- English

In addition to majors, MGSHSS offers Minors in the following disciplines:

- Anthropology/Sociology
- Comparative Literary & Cultural Studies (CLCS)
- Gender and Sexuality Studies (GSS)
- Economics
- History
- English
- Philosophy
- Political Science
- Psychology
- Study of Religion

BSc (Honours) Economics
Graduation Requirement
130 Cr. Hr.

Major Cores 27 Cr. Hr.
 Major Electives 24 Cr. Hr.
 Total 51 Cr. Hr.

BSc (Honours) Politics & Economics
Graduation Requirement
130 Cr. Hr.

Econ Cores 16 Cr. Hr.
 Econ Electives 12 Cr. Hr.
 Politics Cores 12 Cr. Hr.
 Politics Electives 20 Cr. Hr.
 Total 60 Cr. Hr.

BSc (Honours) Political Science
Graduation Requirement
130 Cr. Hr.

Major Cores 12 Cr. Hr.
 Major Electives 40 Cr. Hr.
 Total 52 Cr. Hr.

BSc (Honours) Anthropology / Sociology
Graduation Requirement
130 Cr. Hr.

Major Cores 16 Cr. Hr.
 Major Electives 36 Cr. Hr.
 Total 52 Cr. Hr.

BA (Honours) English
Graduation Requirement
130 Cr. Hr.

Major Cores 8 Cr. Hr.
 Major Electives 44 Cr. Hr.
 Total 52 Cr. Hr.

BA (Honours) History
Graduation Requirement
130 Cr. Hr.

Major Cores 4 Cr. Hr.
 Major Electives 48 Cr. Hr.
 Total 52 Cr. Hr.

BSc(Honours) Economics and Mathematics
Graduation Requirement
130 Cr. Hr.

Econ Cores 28 Cr. Hr.
 Econ Electives 8 Cr. Hr.
 Math Cores 16 Cr. Hr.
 Math Electives 6-8 Cr. Hr.
 Total 58-60 Cr. Hr.

Syed Babar Ali School of Science and Engineering

The LUMS Syed Babar Ali School of Science and Engineering (SBASSE), modelled on some of the leading universities of the world, implements a paradigm shift for science and engineering education in the country, admitting students into a joint science and engineering programme and exposing them to the various scientific and engineering disciplines offered before they are required to choose a major. Its mission is to produce quality graduates who are technically competent problem solvers, and to create knowledge through interdisciplinary research on issues of local and global relevance.

The SBASSE offers a four-year BS degree in the following areas:

- Biology
- Chemical Engineering
- Chemistry
- Computer Science
- Economics and Mathematics (Joint Major)
- Electrical Engineering
- Mathematics
- Physics

In addition to majors, SBASSE offers Minors in the following disciplines:

- Biology
- Chemistry
- Computer Science
- Mathematics
- Physics

BS Biology
Graduation Requirement
131 Cr. Hr.

Major Cores	48 Cr. Hr.
Major Electives	9 Cr. Hr.
Total	57 Cr. Hr.

BS Chemistry
Graduation Requirement
130 Cr. Hr.

Major Cores	47 Cr. Hr.
Major Electives	9 Cr. Hr.
Total	56 Cr. Hr.

BS Computer Science
Graduation Requirement
130 Cr. Hr.

Major Cores	42 Cr. Hr.
Major Electives	15 Cr. Hr.
Total	57 Cr. Hr.

BS Electrical Engineering
Graduation Requirement
133-136 Cr. Hr.

Major Cores	59 Cr. Hr.
Major Electives	17 Cr. Hr.
Total	76 Cr. Hr.

BS Mathematics
Graduation Requirement
130 Cr. Hr.

Major Cores	34 Cr. Hr.
Major Electives	21 Cr. Hr.
Total	55 Cr. Hr.

BS Physics
Graduation Requirement
130 Cr. Hr.

Major Cores	40 Cr. Hr.
Major Electives	18 Cr. Hr.
Total	58 Cr. Hr.

BS Economics and Mathematics
Graduation Requirement
130 Cr. Hr.

Econ Cores	24 Cr. Hr.
Econ Electives	8 Cr. Hr.
Math Cores	11 Cr. Hr.
Math Electives	6-8 Cr. Hr.
Total	49-51 Cr. Hr.

BS Chemical Engineering
Graduation Requirement
135-138 Cr. Hr.

Major Cores	57 Cr. Hr.
Major Electives	18 Cr. Hr.
Total	75 Cr. Hr.

Shaikh Ahmad Hassan School of Law

The Shaikh Ahmad Hassan School of Law (SAHSOL) combines the richness of a liberal arts education with a solid professional training in law. The Law School offers a five-year B.A.-LLB (Honours) degree, fully recognized by the Pakistan Bar Council as a qualifying law degree. LUMS has been offering the BA/LLB programme since 2003; first under the Department of Law and Policy of the School of Humanities and Social Sciences; and since 2012, as one of LUMS' five Schools, housed in its own law school building, benefitting from state-of-the-art student services and facilities.

The B.A.-LLB programme is split into two parts: in the first two years of the B.A. phase, students are introduced to a wide variety of subjects offered by the other schools of LUMS. During this stage of their studies, law students are exposed to concepts and ideas taken from other relevant disciplines such as history, political science and psychology, and are equipped with essential communication and analytical skills. The LLB phase consists of a number of core law courses as prescribed by the Pakistan Bar Council, a wide range of topical elective courses on specialist areas of law as well as practical skills courses, such as Advocacy and Drafting & Opinion Writing. Law students are expected to undertake summer internships at law firms, NGOs and courts.

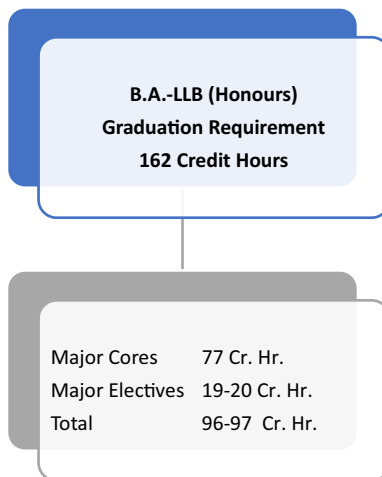

Syed Ahsan Ali & Syed Maratib Ali School of Education

Syed Ahsan Ali & Syed Maratib Ali School of Education is the fifth school at LUMS. The exploratory phase for the School of Education at LUMS was initiated in October 2015, with the objective of enabling LUMS to intervene as a thought leader and change maker in a rapidly expanding educational milieu of Pakistan.

The school offers an intensive full-time MPhil Education Leadership and Management (ELM) programme and an undergraduate minor in Education. The graduate programme at SOE was conceived in response to the rapid expansion in demand for educational services and the resulting explosive growth in Pakistan's education sector. This often-haphazard growth has led to a shortage of well-trained decision-makers and leaders in the sector, such as school principals, managers of school chains, policy analysts and implementers, and higher education administrators. Empowering a diverse student body, SOE aims to produce a new class of educational leaders that will provide strategic direction to a burgeoning education ecosystem.

The school aims to provide for the varying educational needs of a culturally diverse and geographically dispersed student body by preparing them academically, personally, and professionally, and providing them access to opportunities that will allow them to make a difference in the educational landscape.

The Teaching and Learning Initiative (TLI) is a central component of SOE for facilitating students to access practitioners in the education sector. It is envisioned as a vibrant focal point in experiencing field work and hands-on learning in the educational sector. TLI has partnered with a network of schools and educational organizations for the purpose of placing students for the field engagement and the practicum module of the graduate course work. TLI partners include a broad spectrum of educational institutions and organizations including public, private, trust schools, for profit, nonprofit, non-formal as well as Madrassah schools for an enriching varied experience.

Vision:

We seek to operate at the crucial nexus of research, policy and practice, supporting a faculty that is internationally competitive, connected, and relevant. The curriculum, featuring extensive field engagement, will produce graduates capable of becoming strategic leaders, policy researchers, and reflective practitioners, distinctly placed to direct and shape a reimagined and vibrant education reform agenda for Pakistan.

The institution is fueled by the mission to produce future leaders who will *Reflect* thoughtfully, learn to *Redefine* best practices in education, and collectively *Reimagine* an education *Reform* agenda for Pakistan.



Undergraduate Programme Policies & Regulations

UNDERGRADUATE PROGRAMME POLICIES AND REGULATIONS

All students are subject to the University's academic policies and regulations. Students are responsible for ensuring that they meet the University and degree requirements in addition to meeting the academic deadlines.

1. Academic Year*

The academic year at LUMS comprises of two regular semesters, the Fall and Spring semesters. Each regular semester is of 16 weeks. A class scheduled twice a week has 30 sessions in the semester, 15 class sessions for each weekday. Faculty is required to take at least 28 sessions, including midterm examination(s). Two extra sessions can be utilized for regular/review classes (as needed). Graded instruments cannot be taken in these sessions. One week of final examination(s) follows. The Fall semester begins at the end of August and lasts till late-December, while the Spring semester is from mid-January till late May.

**Subject to change owing to COVID-19*

The Summer semester is optional and is of 8 weeks' duration divided into two sessions, I and II, including the final examinations. It is a special accelerated semester with the same contact hours as a regular semester.

2. Student Categories**

The students are categorized according to the number of credit hours earned as follows:

BA/BSc (Honours) and BS Programme

CATEGORY	CREDIT HOURS EARNED
First Year	0 – 30
Sophomore	31 – 60
Junior	61 – 94
Senior	95 – 130 or above

B.A.-LLB (Honours) Programme

CATEGORY	CREDIT HOURS EARNED
First Year	0 – 30
Sophomore	31 – 62
1st Year Law	63 – 94
2nd Year Law	95 – 130
3rd Year Law	131– 162 or above

***For transfer students, the number of credit hours transferred to LUMS count towards the credit hours completed. This grand total, i.e. the number of credit hours transferred and those completed at LUMS, are used in determining the student category.*

3. Undergraduate Programme Policies

Students are required to make/follow a study plan in consultation with their faculty/departmental advisors to complete their degree and major requirements.

The graduation requirements are:

- Successful completion of at least 130 credit hours for the BA-BSc (Honours) programme, 130 to 136 credit hours for the BS programme, and 162 credit hours for the B.A.-LLB (Honours) programme to graduate.
- Completion of all the requirements of at least one major/degree programme.
- Completion of all LUMS courses satisfying degree requirements with a cumulative grade point average (CGPA) of at least 2.00.
- To be a student in good academic and disciplinary standing, and not be involved in any kind of investigation.

3.1. Undergraduate Programme Duration and Structure

The normal duration of the BA-BSc (Honours) and BS programmes is four years. A student can, however, remain enrolled in either of these programmes for a maximum of six consecutive calendar years from the date of admission as a fresh candidate to LUMS.

The B.A.-LLB (Honours) programme is a five-year joint degree with the first two years common with other undergraduate programmes, followed by a three years LLB programme. A student can remain enrolled in this programme for a maximum of seven consecutive calendar years from the date of admission as a fresh candidate to LUMS.

Figure 1 shows the structure of all undergraduate programmes at LUMS. To graduate, students must complete the bin-wise courses belonging to the five categories shown below. For details of individual programme structure, please refer to Academic Departments and Programme Outlines (Section 2).

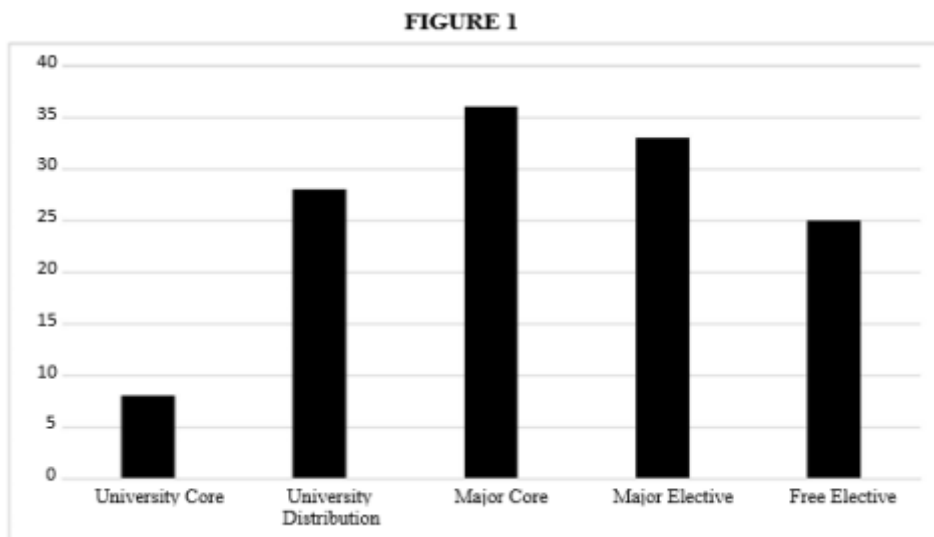

3.2. University Core

The University requires all undergraduate students to study the courses listed below that constitute the University core:

SS 100 Writing & Communication	[4 Credit Hours]
SS101 Islamic Studies (Optional for non-Muslim students)	[2 Credit Hours]
SS 102 Pakistan Studies	[2 Credit Hours]

First year students are required to take University core courses in their first year*. They are pre-registered for the courses and cannot drop them. Students requiring an introductory level remedial course before taking Writing & Communication are pre-registered in a two-credit hour Introduction to Writing (SS 100A) course.

*MGSHSS students, please refer to their school core requirements in Academic Departments and Programme Outlines (Section 2).

3.3. University Distribution Requirements

In addition to the University core, it is mandatory for each student* to complete the University distribution requirements by taking at least seven courses** designated as distribution courses. The distribution requirements ensure that students gain wide exposure to other areas in addition to training in an academic specialty.

The University Distribution Courses are classified into two broad categories:

- In-Group
- Out-Group

Students are required to complete four In-Group and three Out-Group distribution courses. Table 1 lists the In-Group and Out-Group for all majors at LUMS.

*MGSHSS Batch 2022 onwards have no In-Groups. The school core curriculum adequately covers the university In-Group requirement. Batch 2021 would be the last batch to complete In-Groups

**The SBASSE school core requirement adequately covers the University In-Group requirement for Science and Engineering students, hence SBASSE students are required to complete their Out-Group distribution requirement only.

Table 1: Major Wise University Distribution Requirements

SCHOOL	MAJORS	IN-GROUP	OUT-GROUP
SDSB	Accounting and Finance	ECON ¹ , LAW ¹ , MGS ^{1*}	HSS ^{1****} , SE ¹ & EDU ¹
	Management Science	ECON, LAW, ACF ^{1**}	HSS, SE & EDU
MGSHSS****	Economics	MGSHSS Batch 2022 onwards have no in - groups. The school core curriculum adequately covers the university In-Group requirement. Batch 2021 would be the last batch to complete in-groups	LAW & SE (excluding MATH 100)
	Economics and Mathematics (Joint Major)		ACF/MGS (excluding all FINN courses), SE (excluding all Mathematics courses) & LAW
	Politics and Economics (Joint Major)		LAW & SE (excluding MATH 100)
	Anthropology/Sociology		ACF/MGS, SE & LAW
	Political Science		ACF/MGS, SE & LAW
	History		ACF/MGS, SE & LAW
	English		ACF/MGS, SE & LAW
SBASSE	Biology	The SBASSE school core requirement adequately covers the University In-Group requirement for Science and Engineering students, hence SBASSE students are required to complete their Out - Group distribution requirement only.	ACF/MGS, ECON, HSS, LAW & EDU
	Chemistry		ACF/MGS, ECON, HSS, LAW & EDU
	Chemical Engineering		ACF/MGS, ECON, HSS, LAW & EDU
	Computer Science		ACF/MGS, ECON, HSS, LAW & EDU
	Economics and Mathematics (Joint Major)		ACF/MGS, HSS, LAW & EDU
	Electrical Engineering		ACF/MGS, ECON, HSS, LAW & EDU
	Mathematics		ACF/MGS, ECON, HSS, LAW & EDU
	Physics		ACF/MGS, ECON, HSS, LAW & EDU
SAHSOL	Law	HSS, ECON	ACF/MGS, SE & EDU, SCI, ENGG

¹ ECON-Economics, ACF-Accounting and Finance, MGS-Management Science, SE-Science and Engineering, HSS-Humanities and Social Sciences, LAW-Law, EDU – Education

* for SDSB MGS is represented through DISC, for remaining schools MGS represents DISC, MKTG, MGMT & ORCS prefix courses.

** ACF is represented through ACCT, ACF & FINN prefix courses.

*** HSS is represented through ANTH, ENGL, HIST, PHIL, POL, PSY, REL, CLCS, SOC & SS prefix courses.

**** This requirement is applicable only till Batch 2021. For Batches 2022 and onwards, please refer to MGSHSS Core curriculum under Section 2: Academic Departments and Programme Outlines

Distribution requirements are met by introductory level* courses (1XX and 2XX) in a subject area. Additionally, 3XX and 4XX level courses without pre-requisites also count towards the distribution requirement. Distribution courses are of 3 or 4 credit hours.

**An exception is pre-requisites of introductory level courses such as MATH 100: Pre-Calculus (which does not count towards distribution requirements but counts as a free elective).*

ECON 100: Principles of Economics counts towards the distribution requirement for Science and Engineering students as an Out-Group course. In case of HSS (all majors apart from Economics, Politics and Economics, Economics and Mathematics), ACF and Law, ECON 100 is an In-Group course.

Language courses do not count towards distribution requirement. They are letter graded and count towards the Free Elective courses bin requirement.

As a general principle, students cannot count a single course towards more than one requirement, except as defined in the minor policy.

4. Registration of Courses

Semester registration/enrollment is the implementation of the course memo. The course memo is an online course catalogue that contains complete information regarding the courses that are offered by the respective departments in a semester. It is available well before the commencement of the next semester's enrollment. Students are required to plan their courses according to the information available in the course memo and in consultation with their academic advisor/School advisement unit.

4.1. Course Descriptions

Course descriptions facilitate students in course selection for the semester. They are provided by the respective departments/schools, and include information regarding course material, grading components and criteria. They are available in Zambeel before the commencement of enrollment phases of the upcoming semester.

4.2. Course Outlines

Course outlines are available to students enrolled in those courses via the Learning Management System (LMS). These enable the students to understand the detailed requirements of the courses as finalized by the instructors.

4.3. Online Course Evaluations by Students

Students submit the online course evaluations at the end of each semester, prior to the final examination week. During the announced period, the course evaluation forms can be accessed and submitted at <https://evaluation.lums.edu.pk>.

The University provides course evaluation information of previous course offerings. This additional information further facilitates the students in course selection. The previous course evaluations are available at <http://portal.lums.edu.pk/RegistrarOffice>.

5. Phases of Course Registration

The semester course registration is processed in two phases, namely, Enrollment Phases I and II. The Office of the Registrar publishes the semester course registration deadlines for the academic year , and lists details of the process and the respective closure dates for each phase.

Semester enrollment is finalized according to course capacity and eligibility criteria, as defined in the course memo by the respective departments/schools. During the phases of semester enrollment, students provisionally register in requisite courses through their Zambeel self-service. Fee vouchers are accordingly generated by Finance department, with a deadline for the payment of their dues.

For details regarding fee payments, please refer to Section 3: Administrative Offices under the heading Finance Department.

5.1. Enrollment Phase I

This is a school-specific enrollment where students enroll in core and major elective courses according to enrollment appointments for their respective year/level, spread out over a few days.

5.2. Enrollment Phase II

This phase is for students to enroll in distribution and free elective courses. Students (all levels/majors/schools) add their requests by selecting the waitlist option and enrollment is processed according to a random selection. This ensures that all students have an equal chance of enrollment in the requested course.

6. Add/Drop and Withdrawal Periods for Regular Courses and Directed Coursework

Regular Semesters

For regular semesters, Add/Drop period runs for 14 days , starting from 3 calendar days before the start of the semester and continuing till 11 calendar days into the semester. During this period, students may Add/Drop courses. It is further divided into following:

6.1. Add/drop period through Zambeel

Students can add, swap or drop courses through their Zambeel accounts starting from 3 calendar days before the start of semester up to 7th day of the semester.

6.2. Add Only day

After the expiry of add/drop through Zambeel, students have one day (8th day of the semester) on which they can only add or swap courses. Course drop is not allowed on this day except by approval (please see below).

6.3. Add/Drop by approval

This period also starts after the expiry of Add/Drop through Zambeel and ends on the 11th day of the semester. Under special circumstances, students may contact their school coordinator or the coordinator of their major department for course Add/Drop. As appropriate, departments can forward these requests to the Office of the Registrar with the approval of the Department Chair or School Dean for implementation in the system.

6.4. Drop Only period*

This period runs from the 9th day of the semester till the Friday of 5th week of the semester. Students can drop courses up to their specified minimum enrollment limit (Please refer to Section 8. Student Status and Course Load)

*The Drop Only period is further divided according to course drop charges. For further details, please refer to Office of Finance under Section 3: Administrative Offices

Course rosters validating the students enrolled in the courses are communicated to the respective departments/schools at the end of the Add/Drop period, and again after Drop Only period. Students not enrolled in a particular course will not be allowed to attend classes for that course after Add/Drop period, or after Drop Only period for courses which they have dropped. Courses dropped within the Add/Drop period and Drop Only deadline do not appear on the transcript.

6.5. Withdrawal Period

After the expiry of the Drop Only deadline, students cannot drop but may withdraw from courses till the end of the 12th week of a regular semester, as announced in the academic calendar. Students can withdraw from courses via their Zambeel Self Service provided they maintain the minimum load requirement of 12 credit hours. W grade is automatically assigned by the system.

However, under special circumstances, students may be allowed to withdraw from more or all courses bringing their total credit hours to below 12. In such cases, the student should route the request to OSA with proper documentation as to why this is necessary. Following OSA approval, the student will be withdrawn from the necessary courses and W will be assigned to all such courses and visible on the transcript.

Please note that within the duration of the undergraduate programme, a student can withdraw from a maximum of 6 courses (individually) with a W on transcript, as per defined policy. This condition is not applicable when all courses in a semester are withdrawn simultaneously owing to extenuating circumstances. The W grade is visible on the student's transcript and will not be removed even if the student successfully completes the course in a subsequent semester.

The fee for a withdrawn course will not be refunded.

After the course withdrawal deadline, as announced in the academic calendar, students do not have the option of discontinuing the course(s). Discontinuation of course(s) will result in F grade or a grade assigned according to the percentage of course instruments attempted. This grade is visible on the transcript and will affect the CGPA.

Please note that withdrawing from all courses in a semester is not the same as applying to take a semester off before the start of classes. (Please refer to Section 20: Withdrawals)

6.6. Enrollment Wipeout Process

In case of non-payment of dues within the deadline, the provisional semester course enrollment will be wiped out. After the wipe-out process, students who pay the University dues may have their enrollment reinstated provided there are spaces remaining in the required courses.

Students who fail to pay the dues after wipe-out will not be eligible to attend the ongoing semester.

Summer Semester

Please note that there is no Add/Drop, Drop Only or Withdrawal period for the Summer semester. Exceptional cases may be catered to with the approval of the Office of Student Affairs subject to proper documentation being provided. Students are advised to consider this before enrolling into the summer semester.

7. Student Status and Course Load

7.1. Regular Semester

Students are required to take a minimum of 12 credit hours to maintain their regular/active student status. First year students (excluding MGS HSS) can take a maximum of 18 credit hours per semester in their first year whereas MGS HSS first year students can take a maximum of 16 credit hours per semester. Undergraduate students in the Sophomore, Junior and Senior category can enroll in up to 20 credit hours in a regular semester.

Students are encouraged to consult with their school advisement unit to devise a balanced plan of study to complete the graduation requirements in a timely manner. This prevents a situation in which students need to take courses over and above the permissible semester limit, in order to graduate with their cohort. Students who end up in this situation will not necessarily be given permission or be granted priority for registering in courses.

However, in extreme cases (physical/psychological disability), at the recommendation of the Office of Student Support Services, the Office of the Registrar may allow a student to take less than 12 credit hours in one or more semesters. The decision is made on a case to case basis. Similarly, graduating students requiring less than 12 credit hours to graduate can also petition to the Office of the Registrar for taking a smaller workload.

Under special circumstances, students may apply to take **one course** beyond the maximum permitted quota of 20 credits in a semester. Such students are required to have a CGPA of 3.4 or above, or they must be seniors who will be able to graduate within the next two semesters with this accommodation. These students must inform their school advisement unit and the Office of the Registrar so that they may be allowed permission to enroll in the extra credits.

7.2. Summer Semester

While there is no minimum enrollment limit for the optional Summer semester, students are allowed to take a maximum of 4 credit hours per session i.e. maximum 8 credits in the Summer semester.

8. Directed Course Work (Courses Requiring Exceptional Method of Registration)

The undergraduate programme allows students to enrich the independent work/research exposure through Directed Course Work. The enrollment procedure for Senior Year Project, Research Project and Independent Study varies from the normal method of registration and requires prior approval. For all such courses, it is the responsibility of the student to ensure that all the formalities of course registration are complete within the deadline specified by the Office of the Registrar.

The different categories for Directed Course Work (DCW) are listed below:

- Independent Study
- Research Project
- Senior Year Project
- Internship

Cumulatively, the Directed Course Work credits (all listed categories included) can be a maximum of 12 credit hours within the degree tenure. For example, Biology and HSS Senior Projects are of 8 credit hours. They are spread as 4+4 credits across two semesters. The students taking these Senior Projects can enroll in a maximum of only 4 additional Directed Course Work credit hours (Independent Study, Research Project, Internship) in their undergraduate academic career.

Students can provisionally register Directed Course Work (Senior Project, Independent Study, etc.) during enrollment phases, using their *Zambee!* self-service. Prior to the registering of courses, the students are required to submit a DCW online application in *Zambee!*.

Applications for DCW registrations open in two rounds in regular semesters as follows:

- First round starts 3 weeks before the commencement of Enrollment Phase I
- Second round starts 1 week before commencement of Add/Drop period

Enrollment in Directed Course Work is confirmed once the online application is approved by the respective department coordinator, faculty supervisor and verified by the Office of the Registrar.

Directed Course Work grades submission deadline is within the semester absolute grading deadline. If the DCW grade is pending, instructor can assign 'I' grade. After the semester absolute grading deadline, a list of students with 'I' grade is sent to the respective department coordinator, instructor and students, mentioning the 6 weeks' deadline (after the absolute grading deadline). In case the grade is not received by this deadline, two weeks' extension deadline is communicated. After this buffer, an 'F' is assigned in the system.

Opting for Directed Course Work remotely:

The following policy applies if a student wants to register for Directed Course Work, while on visiting/exchange programme in another University or the supervisor is not on campus:

- The student must seek prior approval from the respective faculty supervisor.
- The school/department will decide whether to allow/deny the distant DCW registration.

- In case the student is on an exchange programme, the student will have two supervisors, one in LUMS and one at the institute that the student is attending on an exchange programme.
- Student will present the DCW twice, once while on exchange and again on return to LUMS.
- A final grade is awarded by the respective department once both (external & internal) evaluations are complete.
- On intimation from the department, the Office of the Registrar uploads the final grade of the student in the system.

8.1. Senior Project (SPROJ)

During the Senior year, students can opt for a Senior Project (SPROJ) under the guidance of a faculty supervisor. SPROJ provides students with the opportunity to use their foundational academic skills and content knowledge to gain new, deeper levels of understanding. The project must challenge the student's ability and the chosen topic needs to be of significant value to the student, the school, and the community. This directed learning experience involves thinking analytically, logically, and creatively integrating experience and knowledge to form reasoned judgements and solve problems that will help direct future career and educational opportunities.

Important points to consider while opting for SPROJ:

- Senior Project (SPROJ) can be taken in either/both last two regular semesters.
- In case the SPROJ is spread over two semesters, the student must enroll for SPROJ A in the Fall semester and SPROJ B in the Spring semester of the final year of the degree programme.
- If the SPROJ is spread over two semesters and the student enrolls in SPROJ A in the Spring semester and SPROJ B in the Summer semester, then the student is eligible to attend the convocation next year, subject to the completion of degree requirements.
- A student can take only one SPROJ during his/her degree programme tenure.
- A student can enroll in maximum 4 credit hours' SPROJ in a single semester.
- SPROJ is letter graded.
- Senior Project can range from 3 to 6 credit hours depending on the scope/rigor defined by the respective department/school, exceptionally (BIO, HSS & LAW) SPROJ can be of 8 (4+4) credit hours.
- ECON SPROJ can be of 4 (one semester) or 8 (two semesters) credit hours.
- If it is a 6-credit hour SPROJ, then it is split as SPROJ A and SPROJ B, with the respective assigned codes. It is 3+3 credits over two semesters. However, depending on the rigor involved, it can be 4+4, to be completed in two semesters.
- If SPROJ is spread across two semesters, then it is evaluated once completed and the assigned letter grade is uploaded for SPROJ A and B (unless defined by the department).
- SPROJ group members generally range from 2-8 (not individually) depending upon the complexity and workload approved by the respective department/school.
- Depending on the programme structure, Senior Project can be mandatory or optional.
- In case of optional SPROJ, if the student chooses a Senior Project with major area of study relevant to his/her declared major, it counts towards the respective major elective requirement. If the student chooses a SPROJ with major area of study different from his/her declared major, it counts towards free elective requirement.
- The SPROJ prefix for registration is according to the area of study.

- If a group of students choose an SPROJ area different from their declared major, they need to include at least one member in the group with a declared major relevant to the SPROJ chosen area. For example, if students majoring in Economics wish to do SPROJ in ACF, then at least one group member should be an ACF major. Such students are also required to select two supervisors: one from their own area of study and the other from the selected SPROJ area. Such SPROJ applications are approved by the latter supervisor.

Note: If the Senior Project is to be completed in two semesters, then the final grade for SPROJ A & B (registered in two consecutive semesters) is assigned at the end of the second semester. In the interim, there will be no grade assigned for SPROJ A.

In case a multi term project is not completed within the absolute grading deadline for the former term in which the SPROJ B was enrolled, then an I grade may be assigned if 90% of the coursework is complete.

8.2. Independent Study (IS)

Independent Study is an individual effort to study a particular area in Senior year. It may be opted to complete a student's degree requirements, in case an alternate/appropriate course in that subject area is not offered in that academic year. Students, who opt for an Independent Study will individually complete the requirements under the supervision of an assigned faculty member. They will have to take an exam or submit a report at the end of the semester in order to secure a Pass grade in the Independent Study.

Important points to consider while opting for Independent Study:

- A student who has attained Senior status can register for an Independent Study of at most 2 credit hours in a semester, only in case there is no regular course available to fulfil the credit hour or area requirement.
- Students within the allowed programme tenure, can take a maximum of 4 Independent Study credit hours (spread over two semesters) towards the completion of their Bachelor's degree requirements.
- Independent Study can be done only individually and not in a group.
- Independent Study is graded Pass/Fail.
- A Failing grade will affect the CGPA with no credit given, while a Pass grade will contribute towards the earned credits and will not affect the CGPA.

8.3. Directed Research Project (DRP):

In the Junior year, students can opt for a Directed Research Project individually or in a group. Students are enrolled with a supervisor to mentor the project and guide the students to use their creativity, initiative, and develop the research skills needed for further study or work. Upon successful completion, students can take their research further as a Senior Year Project for deeper level of understanding.

Important points to consider while opting for Directed Research Project:

- A student who has attained Junior/Senior status can register for a Directed Research Project of at most 2 credit hours in a semester.
- Students can take a maximum of 4 DRP credit hours towards the completion of their Bachelor's degree requirements, within the allowed programme tenure.
- DRP can be done individually or in a group of maximum 5 members.
- DRP is graded as Pass/Fail.

- A Failing grade will affect the CGPA with no credit given, while a Pass grade will contribute towards the earned credits and will not affect the CGPA.

8.4. Audit Internship

Audit Internship is a mandatory degree requirement for ACF major students. However, it is optional for MGS majors. It is a supervised work experience that provides valuable educational exposure to augment the academic learning of a student. A student may work as an intern in the for profit and non-profit sectors to earn specified academic credits. ACF internships offer students a hands-on opportunity to work in their desired field. They learn how their course of study applies to the real world, making them stronger candidates for jobs after graduation.

Important points to consider while opting for Audit Internship:

- ACF audit internship is a mandatory degree requirement for all ACF students. Students earn four semester credit hours on successful completion of the internship.
- Audit Internship is graded as Pass/Fail.
- A Failing grade will affect the CGPA with no credit given while a Pass grade will contribute towards the earned credits and will not affect the CGPA.

9. Courses that Require a Separate Mention

The following courses have different grading/evaluation criteria.

9.1. Remedial Course in Writing & Communication

The University, following its process, may require certain students to improve their English comprehension and communication skills by taking a remedial course SS 100A Introduction to Writing (IW). The following rules apply in this case:

- Students requiring IW are pre-enrolled on the department/school's recommendation in this course, in their first Fall semester.
- IW is a two-credit hour course. Students are advised to plan their semester workload in such a way that they are well able to focus on this remedial course.
- IW counts towards Free Elective courses as specified in the degree requirement.
- It is letter graded.
- Students who fail this remedial course in the Fall are required to retake it in Spring the next time it is offered. In case of a second failure, the students are required to take IW a third time, in the next Fall.
- A third failure will result in the student's separation from the programme.
- Students who pass SS 100A are eligible to take SS 100 in the next semester.

9.2. Language Courses

The University offers a large number of language courses. The following rules apply in the case of language courses:

- Language courses are offered with the prefix LANG.
- They are letter graded.
- Language courses do not count towards the distribution requirement.
- They count as Free Elective courses as specified in the degree requirement.

9.3. Waiver for Islamic Studies

Non-Muslim students are exempted from taking Islamic Studies, which is a core course for all undergraduate programmes. These students can take the specified course(s)/Independent study approved as a substitute by the HSS department.

10. Pre-Requisites of Courses

The enrollment phases for the next semester commence prior to the final examinations of the current semester.

The registration system recognizes whether the pre-requisite course has been taken by the student or is in-progress. Ideally, all pre-requisite requirements for a course should be met before registering for the course. This may not be possible if a course and its pre-requisite course are offered in consecutive semesters and the result of the pre-requisite has not been declared at the time of registration. In the event that the student fails the pre-requisite course, it is his responsibility to drop the subsequent course unless permission has been obtained from the school's advisement unit to continue with the course and repeat the pre-requisite course at a later stage.

Pre-requisite and subsequent courses (co-requisites) cannot be taken together in a semester.

11. Cross-listed Courses

Some courses are listed in more than one subject area with separate course codes for the relevant areas. A student may register for the course with only one prefix and the course will count towards the chosen area for the duration of the programme. The chosen course code will not be changed in Zambeel after the Add/Drop period. Students should carefully select the correct prefix while registering in cross-listed courses. Cross-listed courses cannot be re-labelled with a different prefix on the transcript but can be counted towards the requirement of another prefix.

12. Course Repeat and Replace Policy

Students may repeat courses with grade replacement. The grade of both the attempts are visible on the transcript but only the best grade is included in the term and cumulative grade point average (CGPA) calculations.

- Students have the option to repeat a course if they have obtained C- or below (including F) grade. Best grade counts in the CGPA calculation. The credits of repeated course(s) count once towards successfully completed credit hours.
- Students who repeat a course in which they have obtained C or above grade will fall under **all grades count policy**.
- The course grade is replaced only if the same course is repeated. Exception to this rule is only given by the head of department and faculty advisor, provided the course repeated for replacement is substantially similar to the original course. This exception is applicable only in case the original course is not being offered again by the department.
- Repeated courses **do not** count towards **honours and awards**, throughout the degree tenure.
- Students who receive an F grade in a core course must repeat it as a graduation requirement.

Note: Above stated Repeat and Replace Policy is applicable to all batches, for courses taken/repeated/replaced (as applicable), from Fall semester 2017-2018 onwards.

12.1. Policy for Thrice Failure in a Core Course

A student has a maximum of two attempts to clear an F grade in a core course. Students unable to pass a core course in three attempts (including the first time a course is taken) are separated from the programme.

13. Course Audit

Course auditing implies that students can sit through classes but are not eligible to participate actively in class discussions and assignments, nor can they take midterm and/or final examinations. No grade shall be assigned to the student. Other details are:

- Audited courses do not appear on the transcript.
- There is no separate University certificate for course audit.
- In order to audit the course, students must apply to the Office of the Registrar on the prescribed form available at <http://portal.lums.edu.pk/RegistrarOffice>. The course audit forms must be submitted by the 7th day into the semester. In case of Summer semester, which is compressed, forms should be submitted by the first day of classes.
- Permission is granted on first-come first-serve basis, depending upon the availability of seats in the course.
- Certain courses may be closed for auditing at the request of the instructor.
- Students may audit courses in a semester even if they have taken the semester off.
- Students cannot audit courses if they have been separated from the University and await readmission.
- Students may take the course as a regular course after auditing it in a previous semester.
- Auditing a course does not merit availing any University facility. Such students are not provided hostel accommodation.
- Students wishing to audit a course are required to pay the requisite fee. (Please refer to Office of Finance for further details).

14. Course Cancellation

Following the University guidelines and as communicated by the respective departments/schools, the Office of the Registrar processes the cancellation of courses offered in a semester. This decision may be taken at any time during initial course registration or Add/Drop period.

15. Major Declaration and Allocation Process for First year students

Students are required to give preferences for major declaration at the end of the first year. MGSHSS students can declare their major at the end of sophomore year. This is an indication that they have spent a year (or two as for MGSHSS) at the University in their admitted school/programme and wish to continue as such for the rest of their stay at LUMS, intending to graduate with their allocated major. Major declaration preferences are submitted through Zambeel at the end of Spring semester each year. In case first year students wish to change their school/programme, they have the option to apply for the change

simultaneously with major declaration. The students are required to submit their online application along with the completed documents listed in Section 16.5

The major allocation decisions are based on the criteria/requirement(s) as defined by the respective departments/schools, listed in Section 15.1 through 15.4. These decisions are communicated to the students by the Office of the Registrar.

The allocation of a major is based on the student's cumulative grade point average (CGPA), available space and the fulfilment of any other requirement(s) laid down by the respective departments. The student is assigned a major at the end of the Spring semester of first year or as specified by respective school. Summer semester CGPA is not included in major allocation.

The major selection requirements of specific Schools are discussed in detail below:

15.1. SDSB First Year Students Major Declaration

SDSB first year students, as per University policy, are required to select preferences for major declaration through their Zambeel self-service at the end of the first academic year at LUMS. The student(s) are allocated a major according to the defined eligibility criteria.

Students have to select from the list of following majors:

- **Accounting and Finance**
- **Management Science**

For further details regarding SDSB major declaration criteria, please refer to respective school section under Section 2: Academic Departments and Programme Outlines

15.2. MGSBSS Sophomores Major Declaration

MGSBSS Sophomores select preferences for major declaration online through Zambeel self-service at the end of the Second year at LUMS. Depending on the availability of space and cut-off CGPA, the student(s) are allocated a major according to the defined eligibility criteria.

Students have to select from the list of following majors:

- **Anthropology / Sociology**
- **Economics**
- **Economics & Mathematics:** CGPA of 3.3 or better, and a minimum B grade in MATH 101 & MATH 120 required
- **Politics & Economics**
- **English**
- **History**
- **Political Science**

For further details regarding MGSBSS major declaration criteria, please refer to respective school section under Section 2: Academic Departments and Programme Outlines

15.3. SBASSE First Year Students Major Declaration

SBASSE first year students apply online through *Zambeel* for a choice of major. Students whose cumulative GPA at the end of the First year is less than 2.00 in a specific group of subjects designated by the department for major declaration may at the discretion of the department, be refused permission to select that major.

The department-wise requirements for SBASSE major allocation are as follows:

- **Biology:** CGPA of 2.00 or better in Biology and Chemistry courses.
- **Chemistry:** CGPA of 2.00 or better in all subjects and a minimum C grade in Chemistry.
- **Chemical Engineering:** CGPA of 2.00 or better in the following subjects: CHEM 101, MATH 101, MATH 120, and CS 100.
- **Computer Science:** CGPA of at least 2.70 or better in the following subjects: MATH 101, MATH 120 and CS 100.
- **Economics & Mathematics:** CGPA of at least 3.3 or better and a minimum B grade in MATH 101 and MATH 120.
- **Electrical Engineering:** CGPA of 2.00 or better in the following subjects: MATH 101, MATH 120, PHY 101, PHY 104 and CS 100.
- **Mathematics:** An average B or better in MATH 101 and MATH 120.
- **Physics:** CGPA of 2.00 or better in the following subjects: MATH 101, MATH 120, PHY 101 and PHY 104.

Once first year students have been assigned a major, they are re-assigned faculty advisors in their majors. Major-relevant academic advisors are better suited to guide them in their subsequent studies, formulate a stepwise course plan and help them choose a career. The approval of these advisors must be obtained for appropriate course registration in the following years.

15.4. SAHSOL First Year Student Major Declaration

SAHSOL first year students are admitted to the Law programme as Law majors from the first day at LUMS. The Law students re-declare their major as Law through their *Zambeel* self-service at the end of the first year. In case Law student(s) wish to change their school/programme at the end of the first year, the availability of space and cut off CGPA criteria in addition to rule(s)/requirement(s) defined by the prospective school/department apply. Students wishing to transfer into the Law programme need to take Law 101 and Law 102 before applying for a transfer. Acceptance into the programme will be subject to the availability of seats and other criteria established by SAHSOL administration.

15.5. Change in Major/School

After due consultation with the faculty advisor and completion of all formal requirements of the process, students can apply for a subsequent change in major/school at the end of the academic year. They are required to submit the major change/inter-school transfer preferences via their *Zambeel* Self Service.

The Office of the Registrar needs to receive the major/school change applications latest by the end of April. The decision regarding acceptance in the major/programme is finalized based on the availability of space, student's CGPA and the fulfilment of requirements set by the respective School/Department. This process is expected to be completed by mid-June.

The application for Major Change/Inter-school transfer is to be submitted online with the following documents:

- Semester by semester course plan to complete graduation requirements, prepared in consultation with the respective departmental coordinator and faculty advisor.
- Reason for change of major/school along with student's undertaking of financial implications in case of non-completion of the degree requirements within eight regular semesters, taking full responsibility of the fee payment for the additional semesters required.
- Parent/guardian's undertaking of financial implications.
- Parent/guardian's CNIC copy.

Please note that all documentary evidence must be furnished latest by the end of April, to process major/school change applications. Incomplete forms will not be entertained. Subsequent to the major declaration/allocation and school/major change (if applicable) at the end of the First year, a change in school/major is allowed **only once** during the remaining tenure of the degree programme.

For this subsequent school change, a non-refundable processing fee of Rs. 30,000 is charged (applicable from Batches 2017/2018 onwards).

University policy for NOP students and students availing financial aid will apply in case of school/major transfer.

In case of inter-school/inter-programme transfer across all schools/majors:

- All grades count in the CGPA
- The roll number is changed according to the programme requirement.

16. Joint Major

Joint majors provide the richness of two undergraduate major areas. Currently, the University offers Joint Majors in Politics and Economics, and Economics and Mathematics. The degree requirements for Joint Majors are defined and completed within the minimum 130-credit hour undergraduate degree completion requirement.

17. Double Major

After having declared a major, students may opt for a second major (space and fulfilment of other requirements permitting) in their Junior/Senior year, after due consultation with their faculty advisors.

Students need to fulfil the following requirements for a double major:

- Successful completion of minimum 160 credit hours.
- Students pursuing a double major need to complete the University core and the University distribution requirements according to the primary declared major.
- The students are required to complete the core and elective requirements of their primary major.
- They also must complete the core and elective requirements of their secondary chosen major.
- Students must take free electives to complete the minimum degree requirement of 160 credit hours.
- The students are required to maintain a minimum CGPA of 2.5 throughout the programme tenure.

- The maximum time allowed to complete the requirements of the double major is six years from the year of admission at LUMS.
- Students wishing to pursue a double major need to fill the double major declaration form available at the Office of the Registrar portal: <http://portal.lums.edu.pk/RegistrarOffice>.

For further information on Double Major at SBASSE, please see Section 2: Academic Departments and Programme Outlines

18. Minor Declaration

A University minor serves to broaden students' horizons and expand the range of options available to them. Students can complement the study of the major by selecting a minor in an adjacent or related area, thereby sharpening their understanding and deepening the knowledge acquired in their principal area of specialization. A minor can also serve as a basis for and facilitate interdisciplinary study and inquiry. Students also have the option of selecting a minor in an area completely unrelated to their major and can elect to explore particular areas of interest by selecting a discipline much farther afield. Students are in no way constrained or restricted in their choice of a minor and are not obliged to justify their selection by demonstrating its relevance to a particular field or area of specialization.

Minors are being offered in the following University approved areas under their respective departments:

- Anthropology and Sociology
- Biology
- Chemistry
- Comparative Literary & Cultural Studies (CLCS)
- Computational Finance
- Computer Science
- Economics
- Education
- English
- Gender and Sexuality Studies (GSS)
- History
- Mathematics
- Philosophy
- Physics
- Political Science
- Psychology
- Public Management
- Study of Religion
- Urdu

For further information regarding minors please refer to Section 2: Academic Departments and Programme Outlines.

18.1. Rules for Minors

The following rules are applicable to Minors at LUMS:

1. Students intending to minor in a particular area of study should select from the list of minors approved by the University.
2. Students intending to complete a minor should successfully complete a minimum of 6 regular courses, carrying 3 or 4 credits each (for a total ranging from 18 to 24 credit hours), in some combination of required core courses (100, 200 level) and electives.
3. Senior Projects, Independent Studies, or courses with fewer than 3 credits do not count towards the minor.
4. Students intending to complete a minor should achieve a minimum GPA of 2.75 in that area of study (in the six or more courses that make up the minor).
5. Students intending to minor in a particular area cannot count a 100-level course as an elective.
6. Students intending to minor in an area of study must complete at least two electives at the 300 level or higher in that area.
7. The (three) courses that make up the University core, Writing & Communication, Pakistan Studies, and Islamic Studies cannot contribute towards the minor.
8. Of the courses that satisfy the In-Group and Out-Group requirements, no more than one can be used to fulfil the requirements for the minor.
9. A course that is cross listed with another discipline can satisfy the requirements for a major or a minor but cannot be counted twice.
10. Students intending to minor in an area in SSE cannot count more than one SSE core course towards the minor.
11. Politics and Economics (joint major) cannot minor in either Politics or Economics.
12. Economics and Mathematics (joint major) cannot minor in either Economics or Mathematics.
13. The minor requirements can be completed within the credit limit of 130/138 by following a carefully chalked course plan and by taking appropriate courses as free electives to count towards the minor. These students might need to take additional credit hours for the completion of the minor requirements.
14. The minor will only be displayed on the final transcript, NOT on the degree.
15. Students will not be given preference in course enrollment based on their minor requirements.
16. The minor is a look back option and should be declared only at the time of graduation, once the graduation requirements are fulfilled, by submitting the minor form available at <http://portal.lums.edu.pk/RegistrarOffice>. A student cannot declare a minor once the GAF has been submitted as the transcript is already finalized and hence cannot be changed.

All schools have additional requirements for the minor, and students intending to pursue a minor must ensure that they acquaint themselves with them.

For further details, please refer to Section 2: Academic Departments and Programme Outlines.

19. Withdrawals

Withdrawals are broadly categorized as:

1. Voluntary Withdrawal from the University and programme results in the permanent cancellation of the student's active status at LUMS.
2. Semester off from the campus results in withdrawal from that semester only and deactivation of the student's enrolled status for that particular semester.

3. Withdrawal from all courses in a semester, approved by OSA, owing to extenuating circumstances, resulting in all 'W' grades on the transcript for that particular semester
4. Withdrawal from a course in a semester resulting in a 'W' grade on the transcript for that particular course.

Note: Withdrawing from all courses in a semester is **NOT** equivalent to taking a semester off.

19.1. Voluntary Withdrawal from the University and Programme

Students may withdraw voluntarily from the University/programme at any time during the semester. Students wishing to withdraw must inform their faculty advisor in person and submit an online application via their Zambeel self-service, citing the reason for withdrawal. A system-generated notification is sent to relevant offices of the University as necessary. The online clearance process is initiated by the Office of the Registrar and the student is required to follow this process, starting with the return of the LUMS Smart card to the Vigilance department.

Once this process is concluded and the student's university withdrawal request is approved, the student's status is permanently deactivated, and the student is no more deemed a regular student at LUMS. A student who withdraws from the university is eligible to apply afresh or as a transfer student. In case of a transfer student, the student must take admission in another HEC-recognized institution and complete one year of study before applying to LUMS.

19.2. Semester off from Campus

Students may plan to take a regular semester off by submitting an online application via their Zambeel self-service and in consultation with their faculty advisor/school advising unit. In order that this application may be acknowledged and processed by the aforementioned authorities in time, the last day to apply for this will be the day before the commencement of classes for that semester. In case no application is received, it would be treated as Unauthorized Withdrawal. Please refer to Section 20.6 for more details.

- The probationary status of a student remains the same on re-joining LUMS after taking a semester off.
- Taking a semester off may result in a delay in graduation up to a year or even more.
- In case of structured programmes, taking a semester off is discouraged and should be done after consulting the school's advising unit.
- Any semesters taken off will be included in the required degree completion time limit.
- A student cannot take more than two consecutive semesters off.
- First year students are not allowed to withdraw from their first semester.

As the summer semester is optional, there is no need for students to submit this application.

19.3. Withdrawal from all courses in a semester

In extreme emergencies, students can voluntarily withdraw from a semester after the commencement of classes, provided there are medical grounds or circumstances beyond their control. Students are required to submit the online withdrawal application via their Zambeel self-service and upload proper documentation/medical certificate for verification by the Office of Student Affairs (OSA). If the

documentation provided is based on misrepresentation, it is treated as a serious disciplinary matter and the student can be separated from the university. Students on probation, who are allowed to withdraw from a semester, can resume their studies in the following semester with their probationary status unchanged.

19.4. Withdrawal from a course in a semester

Students may withdraw from course(s) till the end of the 12th week of a regular semester, as announced in the academic calendar. Students can withdraw from course(s) via their Zambeel Self Service provided they maintain the minimum load requirement of 12 credit hours. “W” grade is automatically assigned by the system. Please refer to Section 7 for more details.

19.5. Involuntary Withdrawal

In extreme cases the University may insist on a student’s involuntary withdrawal if, according to the judgment of the University officials, the student:

- Poses a threat to the lives or safety of him/herself or other members of the LUMS community.
- Has a medical/psychological condition or demonstrates behaviour that seriously interferes with his/her education and that of the members of the LUMS community.

The involuntary withdrawal process is initiated after thorough verification by the school’s advisement unit, student counsellor and other relevant University officials.

Depending on the severity of the threat, a student’s involuntary withdrawal is categorized as:

19.5.1. Involuntary Withdrawal from the University

On processing of the involuntary withdrawal, the student status is permanently deactivated, and the student is no more deemed a regular LUMS student.

19.5.2. Involuntary Withdrawal from the Semester

In cases where it is judged that the student is able to recover/cope, the student is allowed to take the semester off, on the condition that s/he will provide certain documentation to the OSA before being considered for re-joining. This includes, but may not be limited to, a petition for resumption of studies, medical documentation and an academic plan approved by the student’s school advisement unit. This documentation will be verified by the OSA and the student will be required to have clearance interviews with the Head of OSA and the student counsellor.

These requirements are verified by the Office of Student Support Services, and if recommended, the student may be allowed to resume studies.

The degree completion time criterion is not relaxed.

19.6. Unauthorized Withdrawal

Students who leave the University without prior permission to withdraw are considered to have resigned and their admission stands cancelled.

A maximum of 3 attempts are made via email and a letter to contact such students who are absent from the University without prior information. Students are asked to enroll in their courses within the enrollment period.

Finally, a warning letter and an email is issued to students stating that they are required to complete documentation to take the semester off. If they fail to respond within one week of issuance of this third warning, they are issued an unauthorized withdrawal letter from the programme.

In case it comes into university's knowledge that a LUMS student is simultaneously enrolled in another Regular programme, in another university, he/she will be separated from LUMS with immediate effect.

20. Transfer Students

The following policy holds in case of transfer from other recognized institutions to LUMS undergraduate programme:

- Of the total graduation requirement of 130 credit hours, at least 72 credit hours must be completed at LUMS.
- If credit is given for courses taken at other educational institutions, then credit hours for these courses count towards the graduation requirement as well as major and/or minor requirements. A maximum of 58 credit hours can be transferred but the grades obtained in the completion of these credit hours are not used in the computation of the CGPA at LUMS.
- The Admissions Committee decides the credit limit that can be transferred to LUMS.
- Like other undergraduate students at LUMS, transfer students must graduate within a maximum of six consecutive calendar years from the date of admission. This duration is reduced by one calendar year for every 30 credit hours transferred to LUMS.
- The number of credit hours transferred and those completed at LUMS are used to determine student category, for example, first year student or sophomore.
- Upon admission to LUMS, for a transfer of credits, the student must submit the official, attested course outlines for courses taken at the previous institution to the Office of Admissions. Mere submission of course descriptions and reading material will not be accepted for course evaluation in lieu of proper course outlines. These are then forwarded to the Office of the Registrar for instructors' evaluations within respective departments. Transfer of credits can only be processed after approvals from the concerned departments, subject to satisfying the University defined guidelines below:
 - Course outline/content matching equivalent course at LUMS.
 - Classroom contact hours.
 - Assignment rigour.
- Only courses with B and above grades are eligible for transfer, if approved.
- Only grade C and above that is achieved in courses taken at LUMS will be transferred for external incoming students. To ensure that the rigour of courses is upheld, in the event that somebody takes up a course and gets into LUMS in the following year (next year), it will be at the discretion of the department/school to evaluate and decide whether the course content is still up-to-date and valid for a transfer. The credits of these courses are included in the completed credits, whereas the course grades are neither visible on the transcript nor included in the CGPA calculation.

- A course can only be transferred if evaluated as equivalent to a course offered at LUMS. **Credit given for the courses taken before admission to LUMS will not count towards the semester credit limit required for End of the Year awards.**
- A transfer student can request for a re-evaluation of his/her course outline by sending an email to RO till the first week of the Add/Drop period of that particular semester. After Add/Drop, no student is allowed to request for a second round of re-evaluation of the course outlines.

20.1. Transferred Credits for Courses Taken at Institutions under the LUMS Exchange Programme

Exchange programmes provide an opportunity for LUMS students to study abroad and for foreign students to study at LUMS. The Office of International Affairs (OIA) at LUMS manages student exchange programmes with specific renowned universities throughout the world. Details of these programmes are periodically announced to the student body at LUMS and they are encouraged to apply. For more information, please refer to the section Office of International Affairs under Section 3: Administrative Offices

Before leaving, students should look at the courses they wish to take at the institution they will be visiting as exchange students. Ideally, detailed outlines should be submitted to the Office of International Affairs for onwards submission to the relevant LUMS department(s) for evaluation prior to leaving. Once approved, the Office of International Affairs must inform the Office of the Registrar, so these credits can be counted towards the degree requirements. Also before proceeding, visiting/exchange students are required to inform the Office of the Registrar and apply for semester-off for the period they intend to take courses outside LUMS. The application is submitted on the approved form within the communicated deadline. Students may apply for semester off by submitting an online application via their Zambeel self-service.

Respective departments follow the below defined University criteria for course evaluation:

- Course outline/content matching an equivalent course at LUMS.
- Classroom contact hours.
- Assignment rigour.

On successful completion of the exchange programme students can apply for credit transfer, as per the evaluated course outlines, through the Office of the Registrar after submitting the hardcopy of the transcript of the exchange programme at Office of International Affairs (OIA).

Only courses with B and above grade are transferred. The credits of these courses are included in the completed credits, whereas the course grades are not included in the CGPA calculation.

The maximum number of credits that can be transferred in one semester is equal to the credits which a student can take in a semester at LUMS.

Credits taken during exchange programme count towards the semester credits requirement for the End of the Year awards. In case, students qualify for the End of Year Awards, awards at the time of graduation and for top positions (based on the number of credits), only then, grades of the transferred courses are taken into consideration towards the CGPA/SCGPA requirement of equal to or greater than 3.60. This is to ensure that the university defined CGPA/SCGPA awards' criteria is maintained.

Grades of the courses transferred will not be shown on the transcript or count towards the Semester GPA/CGPA/SCGPA.

20.2. Transferred Credits for Courses Taken by LUMS Students at Other Institutions

Before leaving, students must obtain prior approval to take courses at other institutions as visiting students. This is done by providing the detailed course outlines to their School Dean's office for onwards submission to the respective department(s) for evaluation. Once approved, the School Dean's office must inform the Office of the Registrar so these credits can be count towards the degree requirements.

It is the student's responsibility to ensure that s/he takes only the approved courses at the host institution, to avoid rejection of course credit transfer by the respective department(s), based on the course content provided later. Credits for these courses are transferred to LUMS subject to meeting the criteria of B grade or above. On successful completion of the visiting semester, students can apply for credit transfer as per the evaluated course outlines, through the Office of the Registrar after submitting the hardcopy of transcript at RO.

Credits taken as visiting students count towards the semester credits requirement for the End of the Year awards. In case, students qualify for the End of Year Awards, awards at the time of graduation and for top positions (based on the number of credits), only then, grades of the transferred courses are taken into consideration towards the CGPA/SCGPA requirement of equal to or greater than 3.60. This is to ensure that the university defined CGPA/SCGPA awards' criteria is maintained.

Graduating seniors wishing to take their final semester abroad are strongly advised to ensure that the courses they plan to take at the other institution will satisfy their remaining graduation requirements at LUMS. A failure to do so may result in a delay in graduation.

Grades of the courses transferred will not be shown on the transcript or count towards the Semester GPA/CGPA/SCGPA .

21. Academic Performance

Course grades are visible to the students in their Zambeel self-service, once they are finalized by the course instructor and are then posted in Zambeel by the Office of the Registrar.

21.1. Student Evaluation

Students are formally evaluated by the faculty through appropriate instruments, as specified in the course outline. The defined course instruments are used in grading the course. These may typically include but are not limited to the following:

- Quizzes
- Assignments
- Projects
- Class participation
- Examinations

The instructor informs students about the weightage assigned to each instrument. This is mentioned in the course outline and it is used for evaluating student performance in the course.

21.2. Grading Policy

Course grades are based on cumulative performance in defined instruments.

The final grades are assigned as follows:

Table 2
Letter Grades and their Numeric Equivalents

	LETTER GRADE	NUMERIC EQUIVALENT
Exceptional	A+	4.0
Outstanding	A	4.0
Excellent	A-	3.7
Very Good	B+	3.3
Good	B	3.0
Average	B-	2.7
Satisfactory	C+	2.3
Low Pass	C	2.0
Marginal Pass	C-	1.7
Unsatisfactory	D	1.0
Pass	*P	-
Fail	F	0.0
Withdrawn	**W	-
Incomplete	***I	-
In Progress	****IP	-
Transfer	*****T	-

Grading at LUMS is based on relative performance. However, for some courses, absolute grading is used. This information is mentioned in the course outline.

A+ and **F** are absolute grades. The other grades (**A** to **D**) may be awarded on the basis of relative performance.

***P** grade will contribute towards the earned credits and will not affect the CGPA

****W** has no numeric equivalence and credit hours for withdrawn courses will not count towards the credit hours taken in the semester.

*****I** grade is awarded if a student has completed 90% of the course work (DCW) in the semester and the remaining is to be completed in 6-8 weeks into the next semester (Summer not counted). After the semester absolute grading deadline, a list of students with I grade is sent to the respective department coordinators/instructors and students, mentioning the 6 weeks' deadline. In case the grade is not received by this deadline, two weeks' extension deadline is communicated. After this buffer, an F is assigned on the system. If not repeated and replaced, F grade will count towards Semester GPA, CGPA and SCGPA.

In the case of "I" grade, once the result of the course is announced, the I grade is replaced by attained grade. The semester GPA and CGPA are recomputed and the student academic record is updated accordingly.

If the Senior Project is to be completed in two semesters, then the final grade for SPROJ A & B (registered in two consecutive semesters) is assigned at the end of the second semester. In the interim, there will be no grade assigned for SPROJ A.

In case a multi term project is not completed within the absolute grading deadline for the former term in which the SPROJ B was enrolled, then an I grade may be assigned if 90% of the coursework is complete.

*******T** in the transcript grades column, signifies that the respective course credits have been approved and transferred to LUMS.

21.3. Calculation of Semester GPA

Semester GPA, CGPA and SCGPA are calculated and are based on all courses' grades attained at LUMS. Accordingly, GPAs made visible on the transcript truly reflect the academic performance of a student.

The GPA in a particular semester, i.e., the Semester Grade Point Average, is calculated using the following method:

- The instructor assigns a certain letter grade to a student in a particular course. The numeric equivalent of that grade is provided in Table 3.
- The grade points for all the courses taken in that particular semester are calculated and added together.
- The sum is then divided by the total number of credit hours taken in that semester. The quotient is the Semester GPA.

Table 3
Semester GPA Calculation

COURSES TAKEN	LETTER GRADE	NUMERIC EQUIVALENT	COURSE CREDIT HOURS	GRADE POINTS
Course 1	A	4.0	4	16.0
Course 2	B+	3.3	4	13.2
Course 3	F	0.0	3	0.0
Course 4	W	-	3	-
Course 5	C+	2.3	4	9.2
TOTAL			15	38.4

$$\text{Semester GPA} = \frac{\text{Sum of Grade Points}}{\text{Total Credit Hours attempted}} = \frac{38.4}{15} = 2.56$$

While semester GPA is calculated using all credit hours attempted in the semester (15 in the above example), it is only the successfully completed credit hours (12 in the above example) that count towards the graduation requirements.

Note: Credit hours for withdrawn courses and courses with an F grade neither count towards graduation requirements nor towards the successfully completed credit hours for the semester.

21.4. Calculation of Cumulative GPA (CGPA)

The calculation of Cumulative Grade Point Average (CGPA) follows the same procedure. In this case the calculation is based on all the courses taken since joining the undergraduate programme.

An illustrative example with hypothetical data for CGPA calculation is worked out in Tables 4 and 5:

Table 4
CGPA Calculation (Semester 1)

COURSES TAKEN	LETTER GRADE	NUMERIC EQUIVALENT	COURSE CREDIT HOURS	GRADE POINTS
Course 1	A	4.0	4	16.0
Course 2	B+	3.3	4	13.2
Course 3	F	0.0	3	0.0
Course 4	W	-	3	-
Course 5	C+	2.3	4	9.2
TOTAL			15	38.4

$$\text{Semester GPA} = \frac{\text{Sum of Grade Points}}{\text{Total Credit Hours attempted}} = \frac{38.4}{15} = 2.56$$

In this example, the student has a semester GPA of 2.56 at the end of Semester 1. S/he has attempted 15 course credit hours and successfully completed 12 credit hours, as s/he failed in course 3.

Table 5
CGPA Calculation (Semester 2)

COURSES TAKEN	LETTER GRADE	NUMERIC EQUIVALENT	COURSE CREDIT HOURS	GRADE POINTS
Course 6	A	4.0	3	12.00
Course 7	B-	2.7	4	10.8
Course 8	B+	3.3	3	9.9
Course 9	C+	2.3	3	6.9
TOTAL			13	39.6

$$\text{Semester GPA} = \frac{\text{Sum of Grade Points}}{\text{Total Credit Hours attempted}} = \frac{39.6}{13} = 3.04$$

$$\text{CGPA} = \frac{\text{Sum of All Grade Points}}{\text{Total Credit Hours attempted}} = \frac{38.4 + 39.6}{15 + 13} = 2.79$$

Furthermore, at the time of graduation, SCGPA (Specialization CGPA) is also visible on the transcript and is calculated on the basis of **major cores, major electives and free electives in the area of the major**.

Above mentioned method is applicable even if a student has taken courses beyond the defined credit limit requirement of a degree programme.

21.5. Grade Review Policy

There may be instances when a student believes that there is a discrepancy in his/her final grade. A review of grade plea is acceptable only in the case of a computational error.

If a student wishes to dispute a grade, he or she needs to contact the course instructor. If the instructor does not agree, the student may appeal to the head of the department and in extreme circumstances, to the Dean of the School within two weeks after the final grade is visible in his/her Zambeel self-service.

21.6. Grade Change Policy

In the grade review process, if the student's request is justified and change in grade is approved, then only the instructor of the course can file a grade change petition to the Office of the Registrar within the deadline, using the Grade Change Petition Form available at the Office of the Registrar portal <http://portal.lums.edu.pk/RegistrarOffice>. Department staff/TAs cannot sign in lieu of the instructor. Approval of the head of the department and School Dean is mandatory for the grade change to come into effect.

In case the instructor is no longer associated with LUMS, the head of the department is authorized to review the grade change request.

21.7. Course Pass/Fail Policy

The purpose of the course Pass/Fail policy is to provide students with the opportunity to take courses of interest outside of their major field of study and to learn without concern for the grade having an impact on their GPA. This policy encourages learning diversity and provides students, who have not decided upon a major, the opportunity to explore different areas of study.

The important points regarding this policy are:

- It is the prerogative of individual instructors as to whether they wish to allow their course to be taken as Pass/Fail. The student should only proceed to apply for Pass/Fail for a course if the instructor agrees.
- First year students in their first semester are excluded from this policy.
- A student can choose to designate a course as Pass/Fail till the same date as the Drop Only deadline
- Pass/Fail courses can only count towards the free electives' requirement.
- Hence Pass/Fail courses cannot be taken from within the major core OR elective courses, (even if such courses are in excess of the major requirements), OR count towards the University Distribution requirements.
- In case of a change of major, if the courses previously taken as Pass/Fail fall under the new major core, major elective, or In/Out group bin requirements of the new major, the courses must be repeated with letter grading scheme.
- Pass/Fail courses do not count towards fulfilment of a minor.
- A course designated as Pass/Fail can be repeated only with Pass/Fail grading scheme. Similarly, a course already taken as letter grade cannot be converted into Pass/Fail at the time of repeat/replace.
- Up to 10 credit hours can be taken as Pass/Fail during the entire degree tenure, inclusive of all SWR courses, Independent Study, Directed Research Project, Internship (in case of SDSB students) and any other course previously graded as Pass/Fail.
- C or higher grade attained in a course which has been designated as Pass/Fail will not be visible on the transcript and will not count towards the calculation of Semester GPA, Cumulative GPA and Specialization CGPA. Only the attained Pass/Fail grade is visible on the transcript.
- In a Pass/Fail designated course, a Pass grade is awarded, if the attained cumulative percentage in the course is equivalent to a C or higher grade, as per the grading scale applied to the entire class.
- A Pass grade will have no effect on the CGPA and the credit for the course is earned, whereas a Fail grade will negatively count towards the CGPA calculation with no credit given for the course.
- Pass/Fail Courses are not converted to letter grade for the computation of Honours and Awards. However, these credits will count towards the credit hour requirement for DHL.

22. Attendance Policy

22.1. BA (Honours)/BS/BSc (Honours) Programmes

Students are expected to attend all classes to take full advantage of the learning opportunities. They also need to avoid missing surprise quizzes so that the course grade is not negatively affected.

Some instructors require attendance to be mandatory (with a penalty for missing classes) and have substantial grade reduction associated with absences, as given in the respective course outline for each course.

22.2. B.A.-LLB (Honours) Programme (LL. B Years I, II, and III)

In the B.A.-LLB (Honours) programme, attendance is mandatory. Missing four or more cases can result in the penalty of a reduction of one letter grade from a student's eventual overall letter grade. Furthermore, anyone who is ten minutes late for a class is marked absent, unless s/he has a legitimate excuse communicated through prior notification to the teacher or in exceptional cases, formally communicated after class to the instructor or TA.

23. Examinations

The Office of the Registrar allocates auditoriums for conduction of examinations. As a norm, the mid-term and final examinations follow the regular class meeting pattern. Students are strongly advised to take courses keeping this in mind. As a norm, large classes and courses requiring combined examinations are planned on the weekends or the late evening time slot during weekdays. Students are required to take examinations as scheduled. For missed examinations, refer to Policy No. 24 on Make-up Policy for Graded Instruments.

The following additional detail relates to the conducting of examinations at LUMS:

- During an examination, a student may not leave the auditorium without the permission of the invigilator. If allowed, only one person at a time is allowed to go out of the room.
- No question papers and answer books are to be taken out of the examination room during the examination.
- All students are required to bring their LUMS student smart card for the examination. The invigilator and/or instructor reserves the right to check the ID of the students.
- Mobile phones and other communication devices are not allowed in the examination venue.
- The duration of an examination is determined by the instructor and no extension in the time is given unless allowed by him/her.
- Students are not allowed to enter the examination room if they are late by more than 30 minutes. No extra time is granted.
- Students may not leave the auditorium till 45 minutes of the examination time has elapsed.
- In case of natural/medical emergencies, students may be allowed to leave the examination room accompanied by an invigilator.

24. Make-up Policy for Graded Instruments

The purview of this policy shall include all instruments/sub instruments of a course.

Absence from examinations is permissible only in extreme situations, beyond the control of the student. These include medical cases, death in the immediate family, extracurricular activities (where the student is officially representing LUMS), visa cases (for higher studies) and other emergencies.

In such circumstances, student, or someone on his/her behalf, must submit an application to the instructor (in case of instrument less than or equal to 10% of the aggregate) OR the Office of Student Support Services (in case of all instruments worth more than 10% of the aggregate) along with other required documents within three days of missing a graded instrument. The possible options include assigning average grade based on performance in other instruments, allowing a retake of the instrument or denying the petition and assigning a zero score for that instrument. In the case of an instrument with multiple sub instruments, such as quizzes, the instructor may apply best (N-X) policy.

An average score is not awarded for quizzes that are missed due to late enrollment in course(s).

For any individual instruments that constitute less than or equal to 10% of the aggregate, the instructor shall have the prerogative to mark the student an average of his/her performance in the course or take a makeup examination after ascertaining the circumstances of the missed instrument. In these cases, student may contact the relevant instructor for necessary approval.

For any individual instrument that constitutes more than 10% of the aggregate, a request for scheduling a make-up exam must be made by the student or someone on his/her behalf, on the Make-up Exam Petition Form which is to be submitted to the Office of Student Support Services (SSS) along with the other required documents, **either prior to or within three days of the exam**. The petition is processed by the SSS after due diligence and the student is notified of the decision, at most within a week. It may either be fully accepted or with penalty in case of inadequate documentation.

If the petition for any instrument filed at the SSS is accepted, the instructor is notified by the SSS and a makeup exam is scheduled by the instructor within two weeks of the original exam.

For all approved cases, there is no grade reduction on makeup exams. The make-up exam can also be substituted by an "average score" by the instructor, according to the student's performance in the rest of the course instruments.

- **If the petition is accepted with penalty** for marginal cases, the instructor has the discretion to either take a make-up or assign an average score with up to 20% grade reduction as penalty.
- **If the petition is declined by the SSS**, the instructor still has the discretion to take a makeup exam or assign an average score.
- In both cases, the marks are subject to a mandatory up to 20 % grade reduction as deemed fit by the instructor.

If the make-up exam option is taken, the make-up exam must be conducted by the instructor within two weeks of the original exam date, in case of a regular semester and within a week in case of a final graduating semester.

Private arrangements for make-up examination between a student and an instructor are not allowed.

Students who miss a scheduled make-up exam will not be given a second chance. Students who have already attempted an instrument cannot petition for a makeup examination for the same instrument.

Makeup exam petitions shall only be entertained for ONE of the two major instruments in a course (e.g. either the midterm exam or equivalent or, the final exam or equivalent).

An average score is not awarded for quizzes that are missed due to late enrollment in course(s). Make-up exam policy is applicable to the below mentioned situations:

24.1. Medical Cases

The student must first consult with the LUMS Medical Center, a 24-hour service on campus. Subject to verification of the ailment based on the prescription and referral over the serious nature of the illness deemed enough for the instrument to be missed, a makeup exam petition should be filed to the SSS within days of the exam date. This written assessment from the LUMS physician on duty must be obtained while the student is ill. The SSS may further consult with the Medical Center to decide on such petitions.

In cases where the student is out of station, or at a distance from the campus and is seriously ill, the student should submit complete information on the medical treatment, i.e., copies of the clinical reports, hospitalization details, etc. to the Office of Student Support Services, upon his/her return to the University after recovering from illness

In extreme cases, where it is not possible for the student to see the doctor, the student should immediately write to SSS (osa@lums.edu.pk) to inform of the predicament for consideration on merit, explaining why it was not possible to see the physician at the LUMS Medical Center.

24.2. Death in the Immediate Family

In the unfortunate event of a death in the immediate family (parents, siblings, or grandparents only), students should file a makeup exam petition to the SSS within a week of the demise. The Office of Student Support Services may need to verify the documentation and will inform the student regarding the decision.

24.3. Extracurricular Activities

If a student is proceeding to participate in an event which is considered prestigious by the University, the patrons of the relevant societies/clubs should try to negotiate a date for the event with the event organizers that does not conflict with the midterm/final exam schedule. If the negotiations fail, the patron should inform the SSS at a minimum one week in advance and get prior permission from the Dean Student Affairs, for the students to participate in the event.

In case of an international event, one extra day before and after the event to account for travel logistics, can be petitioned for. Extra days spent on private extension of the trip will not be permissible for petitions for leaves.

In case of sports events, students participating in:

- HEC inter-varsity events,
- games organized on national/regional or international scale at a minimum University level,
- inter-varsity competition organized by a University or LUMS itself – with more than two teams participating,
- an international fixture

- may file a petition three days in advance of the event. All sports events other than the ones prescribed in this policy are declined.

The course outline can specify the maximum number of petitions for extra-curricular activities that are allowed in a course and the penalty for missing a class. Furthermore, the course outline may state that a student will not be eligible for an examination if s/he has not attended a certain number of classes

24.4. Visa/Employment Cases

Students who have applied for a study or immigration visa or employment at any organization (in case of senior students) and have been called for an interview on the date of an exam are allowed a makeup exam without grade reduction. Such students should submit complete supporting documents to the Office of Student Support Services within three days of the interview. Cases for all visas other than the ones indicated in this policy are declined.

24.5. Weddings, Other Emergencies

Petitions for wedding/marriage events of self or siblings only shall be permissible. All assorted documentation must be provided for the purpose within three days to the SSS.

For other emergencies, the student will apply to the SSS either prior to or within three days of the exam, with the provision of adequate documentation that establishes the emergency.

25. Academic Standing

Academic standing is a measure of the student's academic achievement, relative to his/her degree requirements. It determines the eligibility to continue in the chosen academic plan and to qualify for graduation.

To remain in good academic standing, students are required to maintain a minimum CGPA of 2.00 at the end of each regular semester and during their study.

25.1. Academic Warning

Academic warning (unlike probation based only on CGPA) is based on the regular semester GPA as well. A warning letter is issued to indicate that students must seriously focus on their studies, as they run the risk of being put on probation if they do not improve their academic performance.

Warning letters are issued:

- If the Semester GPA in any regular semester falls below 2.00, regardless of the CGPA.
- If CGPA is below 2.50 but is above 2.00.

25.2. Probation and Separation

The academic performance of a student is closely monitored by the Office of the Registrar, especially during his/her warning and probation period. Students who fail to demonstrate a marked improvement in their academic performance while on probation are separated from their respective academic programmes.

Students may go on probation without receiving an academic warning beforehand.

A student is placed on academic probation as listed below:

- If the CGPA falls below 2.00 at the end of any regular semester.
- If the CGPA of the student is below 2.00 for two consecutive regular semesters (Fall and Spring), then s/he is separated from the programme.

Note: If the academic performance of a student improves and CGPA is equal to or above 2.00 then the student regains good academic status.

25.2.1. Probation/Separation Conditions for First year students

If Semester GPA in any semester falls below 2.00, regardless of the CGPA the student is advised (by respective department/faculty advisor) to take less semester workload. Such students will not be allowed to take more than 14 credit hours in the semester.

In case of first year student, if the CGPA falls below 2.00 at the end of the Fall semester (first semester after admission), the student is placed on probation in the next regular semester, i.e. Spring semester. After the Spring semester, if CGPA remains below 2.00 then the student is separated from the academic programme with immediate effect.

Please recall that first year students are not allowed to take the first semester off. If a first year student while on probation takes the second semester off, s/he is placed on academic probation in the semester that s/he re-joins.

25.2.2. Probation/Separation conditions in the Subsequent Years at LUMS

In the subsequent years, the probation period can be extended over a maximum of two regular semesters (Fall or Spring).

To this end, Probation Semester GPA (PSGPA), which is the cumulative CGPA since the beginning of probation, is tracked. The PSGPA ascertains the student's performance subsequent to probation and determines whether student continues to be on probation or is to be separated. Figure 1 presents these conditions.

Probation Semester GPA (PSGPA): Process Flow Diagram

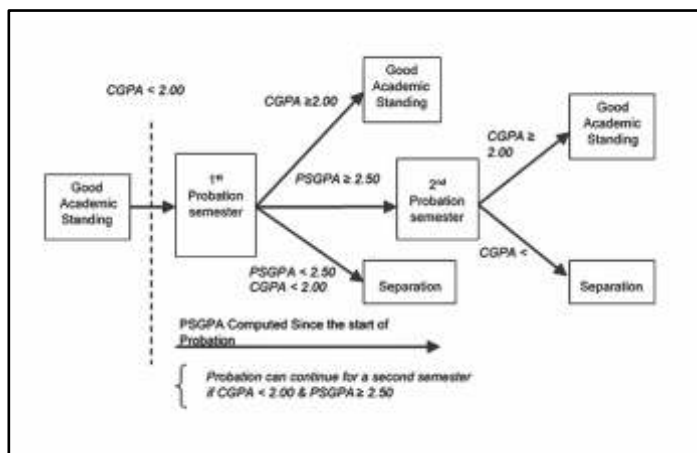

Probation is extended for only one regular semester for students having a PSGPA equal to or more than 2.50 at the end of first regular probation semester, while the CGPA is still below 2.00.

If the CGPA remains below 2.00 at the end of second probation semester, the student is separated from the programme.

Students on probation, who are allowed to withdraw from a semester, can resume their studies with their probationary status unchanged. Please note that decisions regarding academic standing are taken at the end of regular semesters only.

Senior Year Students: For courses, which are spread over two consecutive semesters (e.g. Senior Projects), grades are finalized at the end of the course. Students will receive the same finalized grade in each semester over which the course was spread. As a result, if the student's CGPA falls below 2.00 in two consecutive semesters, the student are separated from the programme with immediate effect. In such cases separation from the programme takes place without the student being placed on probation.

25.2.3. Curb on Co-Curricular Activities for Students on Probation

For students on probation, involvement in co-curricular activities should be limited till the regaining of good academic standing. Students on probation cannot take part in extracurricular activities and events which will result in them missing graded instruments at LUMS.

Students on probation cannot serve as office bearers or shoulder responsibility in any student organization, club, society or extracurricular activity. It is the student's responsibility to inform the respective organization and resign from such a position. Failing to act responsibly may expose the student to disciplinary proceedings.

25.2.4. Probation and Separation Letters

Students who are placed on probation or are separated from the Programme are informed via email and letters. Probation and separation letters are also dispatched to parents through courier service on their mailing addresses available in Zambeel.

25.3. Readmission upon Separation

Students separated from the programme based on academic performance are eligible to apply for readmission. For further information, refer to the Readmission Conditions in Section 25.3.2.

The Disciplinary Examination and Appeals Committee (DEAC), following the University defined guidelines, has the discretion to accept or reject applications. Readmission is offered only in those cases in which there is clear evidence that the causes leading to poor academic performance in the past have been removed.

All readmission applications should be addressed to the Convener, Disciplinary Examination and Appeals Committee and sent to the Office of the Registrar, LUMS for deliberation by the committee.

If senior year students, i.e. students who have completed 95 or more credit hours, are eligible for separation (For Law students, the senior category is determined at 118 or more credit hours), the Disciplinary Examination and Appeals Committee may recommend continued probation, suspension (mandatory separation for a fixed number of semesters) or any other conditions applicable on a case to case basis.

In cases where senior category readmitted students are eligible for separation ; the above-mentioned policy is not applicable. The conditions specified in their readmission letter are applied to such students and they are separated with immediate effect.

25.3.1. Continuation of Semester after receiving Separation Letter

Students subsequently separated from the programme based on their academic performance , but enrolled in the Summer semester (immediately after separation), are given **the option** to drop the course(s) without any penalty, if they inform the Office of the Registrar before mid-semester. In such cases, the courses are removed from the transcript and fee is refunded.

However, if the student does not opt to drop courses taken in the Summer semester, the courses will show on the transcript with the grades assigned by the instructor(s). In case of readmission, the Summer course grades are not counted towards the CGPA but the credits are transferred subject to meeting the readmission criteria.

The above policy regarding Summer Semester is also applicable in case of final separation of a student.

25.3.2. Readmission Conditions

- Students are only eligible to apply for readmission within two weeks from the issuance date of the separation letter.
- Students who are separated on academic grounds and then are readmitted are placed on academic probation for the rest of their stay at LUMS.
- Readmission fee is applicable as per University policy.
- Students can be readmitted only once.
- Students separated from the programme based on disciplinary action will not be considered for readmission, nor will they be eligible to apply as fresh candidates.
- It is mandatory for students separated from the programme on academic grounds to take next regular semester off unless the DEAC decides otherwise.
- All courses taken by a student at LUMS will show on the transcript, even if the student has been readmitted.
- Courses with grade C+ or above are given as credits on readmission.
- Credit hours of courses for which credit is given on readmission count towards the graduation requirements, but the course grades are not included in the calculation of CGPA and specialization GPA.
- After readmission, in the first regular semester (Fall or Spring), the students are required to obtain a minimum semester GPA of 2.50. Please note that as per University policy, the academic standing decisions are taken at the end a regular semester. They are required to maintain a minimum CGPA of 2.00, thereafter, at the end of each regular semester to continue with the programme. In case their CGPA dips below 2.00 in any regular semester, they are separated from the programme without any warning.
- In case of readmission, the student must finish the undergraduate programme within the maximum allowable time for the respective programme i.e. six years (BS/BA-BSc) and seven years (B.A.-LLB) from the original date of joining LUMS.
- Readmitted students who are subsequently finally separated from the programme on academic grounds cannot apply as fresh candidates.

- Once a student has been separated from LUMS (at any stage) on academic grounds and has not been readmitted, s/he is allowed to apply as a fresh candidate only once.

25.4. After Withdrawal or Separation

Students who withdraw, are separated or leave the University without informing the Office of the Registrar at any time during the year may apply for online clearance using Zambeel self-service. Upon successful online clearance from all respective departments, the student is entitled to get his/her final settlement done from LUMS. In case a student does not get clearance or does not complete the clearance process, the security deposit is not refunded.

Online clearance is mandatory for the student to be eligible for the issuance of any official university document.

26. Graduation Tracking

To fulfil the graduation requirements students must be in good academic standing. They cannot graduate while being on academic probation.

The process for graduation is defined below:

26.1. Graduation Audit Form (GAF)

To assess if all the graduation requirements have been fulfilled, students in their final semester are required to confirm in Zambeel that they wish to graduate.

Only the students who complete their graduation requirements in their final semester, i.e., the Spring semester (in case of late/early graduates in the prior Summer or Fall semester) of the academic year and submit their Graduation Audit Form (GAF) within the announced deadline, are allowed to participate in the upcoming annual convocation. Once the GAF has been submitted and requirements have been verified by the respective department/school and the Office of the Registrar, the student's course enrollment is locked.

Please note that a different major other than the one assigned in Zambeel cannot be declared at the time of submission of GAF. This rule holds true even if the student has fulfilled the graduation requirements for that particular major

All students who are eligible for graduation in a particular year, irrespective of their enrollment year, are in competition for graduation honours.

Students who are involved in a disciplinary case and have not fulfilled the penalty, may not be allowed to participate in the convocation ceremony.

Students with outstanding dues, or with their status on hold by the Financial Aid Department may be allowed to attend the convocation ceremony. For all such students, the academic documents remain on hold till the University decisions in their regard are fulfilled and the University clearance process is complete.

Students wishing to withdraw their GAF application, s/he should inform the Office of the Registrar within 14 days after the semester final examination week. Withdrawal requests after the deadline will not be entertained.

26.2. Other Graduation Clearance Requirements

The clearance of graduating students by all departments at LUMS is done through Zambeel. Office of Student Support Services (SSS), which falls under the Office of Student Affairs, initiates the clearance process for the tentative graduating students.

Students need to fulfil the following requirements for Graduation Clearance:

- Submit an undertaking and return the specified items to the respective departments, latest by the deadline announced by the OSA.
- Return all borrowed books and other issued material to LUMS library, student clubs, IST etc.
- Clear any outstanding dues.

If any item is pending against a graduating student, the respective department will update the requisite status in the student Zambeel self-service. Each student is able to view status of his/her clearance in Zambeel. If dues are pending, student will receive fee voucher in his/her self-service. To avoid any hindrance in graduation, the dues must be cleared within the stipulated deadline.

Only students fulfilling the clearance requirements are allowed to attend the annual convocation and receive degrees.

Students who do not wish to attend the Annual Convocation after confirmation should inform the Office of the Registrar within 14 days after the semester final examination week.

Students willing to attend the convocation after declining the initial request to attend also need to inform the Office of the Registrar within 14 days after the semester final examination week.

Note: Any request after the above-mentioned deadlines will not be entertained.

26.3. Graduation Denied

A student's name is removed from the list of graduating students if:

- The student is unable to fulfil his/her graduation requirements in the final year or final semester
- The student is involved in an unprofessional/disciplinary/Values & Ethics (V&E) incident or is barred from attending the convocation by the relevant Committee.

In case of ineligibility to graduate, students are informed by the Office of the Registrar.

26.4. Name on Transcript and Degree

After admission to LUMS is confirmed, student profiles are created in Zambeel. The information in the profiles is transferred from the on-line admission application filled by the admitted student. After enrollment and registration, it is the prime responsibility of the student to review his/her respective profile during the LUMS Orientation Week. If there is any discrepancy, especially in the name and/or the date of

birth, the student should get it rectified by submitting a duly filled Personal Information Form at helpdeskro@lums.edu.pk available at RO Portal.

The name on the transcript and degree is printed from the information available in Zambeel, which is considered final.

Note: As per the instructions of the Higher Education Commission, Pakistan (HEC), the name, father's name and the date of birth of a student must be the same throughout his/her educational testimonials such as Matriculation, Intermediate, Bachelors and Masters onwards to PhD Degrees/Transcripts, as well as on Computerized National Identity Card/ Passport. Otherwise, the documents will not be attested by HEC.

26.5. Degree before Convocation (DBC)

Upon successful completion of degree requirements and issuance of the final transcript, student can apply for his/her degree prior to the convocation. The Office of the Registrar charges the student and issues the DBC. This degree is printed with text "Degree before Convocation" (DBC). The DBC must be returned before or upon receiving the regular degree at convocation.

All LUMS dues must be settled before a request is placed for DBC, or else the degree is not issued and remains on hold till the dues are settled.

26.6. Award of Regular Degree on the Convocation Day

On the day of Convocation, degrees are awarded only to the graduating student in person. After the convocation, graduates may authorize their representative to collect the degree from the Office of the Registrar on their behalf on working days between 1500 hrs to 1700 hrs, by writing to RO and providing CNIC or LUMS Smart card details of the authorized person.

26.7. University Clearance, and Security Refund

Once admitted, all students upon leaving the University, must go through the University clearance process. The Security amount which is deposited by a student at the time of admission is refundable, after graduation/withdrawal/separation/admission cancellation/unauthorized withdrawal from the respective programme through LUMS Online Clearance Process.

A student who has withdrawn from LUMS, has been separated/dismissed/expelled, has had his/her admission cancelled or has left the University without informing at any time during the year, should apply for clearance using Online Clearance (Zambeel Self-Service) System. The online clearance process is initiated by the Office of the Registrar and the student is required to follow this process starting with the return of the LUMS Smart card to the Vigilance department. It can also be dispatched at the following address to process security refund: Security Office, Vigilance, LUMS, Lahore.

The student is entitled to his/her final settlement by LUMS upon successful (online) clearance from all respective departments. University documents (transcripts/letter/attestations) are issued by the university subject to successful online clearance.

27. Academic Honours at LUMS

The academic honours encompass end of semester recognition, end of the year recognition and all the way up to honours and medals at the time of graduation. Please note that repeated courses do not count towards honours and awards, throughout the degree tenure.

The University has defined policies to recognize high achievers and best performing students as discussed in detail below:

27.1. Honours

At the time of graduation, excellence in academic performance is recognized, according to the below listed criteria:

- Graduation with High Distinction CGPA of 3.8 and above, mentioned on transcript and award of High Distinction plaque and certificate.
- Graduation with Distinction CGPA of 3.6 to 3.79, mentioned on transcript and award of Distinction plaque and certificate.
- Graduation with High Merit CGPA of 3.30 to 3.59, mentioned only on transcript.
- Graduation with Merit CGPA of 3.10 to 3.29, mentioned only on transcript.

27.2. Medals

- At the time of graduation, all graduating students compete for the medals/awards.
- If an external transfer student secures highest GPA among the students of his/her graduating major s/he will be considered for awarding of medal along with the any other regular student as per his/her performance and eligibility criteria.
- However, if a student who obtains admission at LUMS with 58 credits (after completing 58 credits at the host university) and takes another exchange semester at another university but does not complete 72 credits at LUMS, will not be considered for a medal.

27.2.1. National Management Foundation (NMF) Gold and Silver Medal for Overall Top Positions

- The student with the best academic record, having the highest CGPA within the range 3.90 to 4.00, receives a gold medal for overall first position.
- The student with the second highest CGPA, which should not be less than 3.60, receives a silver medal for overall second position.

In case there is a tie for the overall first position and the overall second position, the tie is broken according to the following University defined criteria:

- CGPA is extended up to 6 decimal places for comparison; the student with the highest CGPA thus established, is eligible for the medal.
- If the tie still remains, the highest number of A+ or A grades obtained in 3-4 credit hour courses are counted. The student with the highest number of A+ or A grades will qualify for the medal.
- In case the tie remains, both students receive the gold medal and there is no silver medal.

- If the overall first position is not tied, then for the overall second position, in case of a tie, the above defined University process is followed.

27.3. Medals – Specialization (Major)

At the time of graduation, student with the best academic performance in the area of specialization (major), having SCGPA equal to 3.85 or higher and CGPA equal to 3.60 or higher, receives the major gold medal.

In case there is a tie for the top position in the area of specialization, the tie is broken according to the below University defined criteria.

- SCGPA is extended up to 6 decimal places for comparison; the student with the highest SCGPA, thus established, is eligible for the medal.
- If tie is not broken, the student with the higher CGPA will qualify for the medal.
- In case the tie still remains, the highest number of A+/A grades that count towards the major are considered. The student with the highest number of A+ or A grades will qualify for the medal.
- In case the tie remains, both students will receive the specialization gold medal.

27.4. Undergraduate Semester Wise/End of the Year Academic Recognition

At the end of each regular semester/academic year (Fall and Spring semester only), students who have performed exceptionally well are placed on the Semester and/or End of the Year Dean’s Honour List. The following criteria must be met by the undergraduate students for academic recognition.

Semester (regular) recognition: Students who have successfully completed at least 16* credit hours in a regular semester and have achieved a semester GPA of 3.60 or above (computed based on the courses taken in Fall or Spring semester, not applicable in case of Summer semester) are placed on Dean’s Honour List. The remarks “Placed on Dean’s Honour List” are mentioned on the transcript. There is no University ceremony for such a recognition.

**Not applicable in case of final semester before graduation.*

End of the Year recognition: Top position holders with the best academic performance are recognized, as per University policy.

In case of a tie in the end of the year award for overall top position in each category (Sophomore, Junior, Senior), the following University defined criteria is followed:

- CGPA is extended up to 6 decimal places for comparison; the student with the highest CGPA, thus established, is eligible for the top position.
- If the tie still remains, the highest number of A+ or A grades obtained in 3-4 Cr. Hr. courses are counted. The student with the highest number of A+ or A grades will qualify for the top position.

After considering the grades, if a tie still remains, then the student who has completed highest number of credits (in the particular academic year) will qualify for the top position.

Students are also placed on the End of the Year Dean’s Honour List upon successful completion of at least 32 credit hours in an academic year (two regular semesters: Fall and Spring only), with a Cumulative GPA of 3.60 or higher (CGPA calculated since admission term).

Only in the case of first year students, the minimum credits to be completed in order to be eligible for DHL is 30 Cr. Hrs. (instead of 32), the CGPA should however still be 3.60 or above. For the remaining years, it is mandatory to complete 32 credit hours as mentioned above. This is applicable to all schools at LUMS.

Such students are acknowledged with remarks “Placed on Dean’s Honour List for the academic year (XXXX - XXXX)” mentioned on the transcript. A University ceremony is also held in their honour and a certificate is awarded.

28. Important Policies regarding Code of Conduct at LUMS

One of the aims of the programmes at LUMS is the development of personal and professional ethics among students. Students are expected to conduct themselves as professionals in all aspects of their life at LUMS. Fines may be imposed in case of violation of norms of the University.

Unprofessional behaviour can also result in dismissal from the programme. A student dismissed for unprofessional behaviour will not be considered for readmission. Professional conduct covers a wide range of activities, from interpersonal behaviour to maintaining and enhancing the professional values of the University. In case of any doubt about appropriate behaviour, students must immediately consult their class coordinator, Head of Department for their major, Faculty Advisor or any member of the faculty.

The University expects all LUMS students to take responsibility of their actions on campus as well as off-campus. Their behaviour should reflect a respect of law and their contractual obligations, a consideration of the rights of others, the University code of conduct in academic and non-academic matters, and shared standards of considerate and ethical behaviour.

Students at LUMS are aided in their academic pursuits by various individuals and groups, including faculty, academic advisors, programme coordinators and staff at the Office of the Registrar and the Office of Students Affairs. However, each student is ultimately responsible for knowing and complying with all the information, policies, procedures and deadlines listed in this handbook. Questions should be directed to the appropriate offices.

28.1. Some Norms of the University

- Students are to maintain proper decorum and etiquette and adhere to accepted local social norms while interacting with their peers, faculty members, guest speakers and the staff at LUMS. The same sensitivity should be exhibited in their dress code.
- While on campus, students are expected to dress formally for interviews, class presentations, seminars by guest speakers, and other academic events.
- In public places like library, auditoriums, computer labs, and the Pepsi Dining Centre, disruptive behaviour is considered unprofessional. Students should refrain from being noisy in the corridors as this disturbs the classes.
- Students must not engage in any activity that may result in damage to the University property.
- Students should not indulge in behaviour, within or outside LUMS, which may tarnish the image of the University.
- Smoking is not allowed indoors. Please see the smoking policy below.

- Phones in the faculty and staff office areas are not to be used by students.
- Activities such as eating, and drinking can only be carried out in designated areas. Food and drinks, except for water, are not allowed in classrooms, discussions rooms, computer labs and the library.
- Students are expected to keep the campus clean! Littering on campus is completely unacceptable.
- It is the student's responsibility to ensure that the security, rules, regulations and behavioural norms of the University are not violated by their guests.
- Students should not be late for classes and should not leave the classroom when the class is in session, except under exceptional circumstances with the permission of the instructor.
- During class, the instructor should not be interrupted by any of the following:
 - Late arrivals.
 - Unsolicited comments by students.
 - Disruptive behaviour of students, exchange of notes and cross talk.
 - Ringing of mobile phones.
- Students should adhere to all the rules stated in the course outlines for their respective courses.

28.2. On-Campus Smoking Policy

As part of the University's commitment to the health, comfort and safety of all members of its community while respecting individual choice, the following on-campus smoking policy applies to all students, faculty, staff, as well as all guests, contractors, vendors and temporary workers visiting the campus.

Non-Smoking Rules: Smoking is **prohibited inside or at the entrance of any University building**, substantially enclosed workplace, and University vehicles. (A substantially enclosed workplace is one which has a ceiling or roof and where openings - other than doors and windows - constitute less than half of the enclosure). The smoking of *sheesha* or other similar contraptions is strictly prohibited all over campus at all times.

Smoking Rules: Smoking is permitted in open spaces at a **suitable and reasonable distance from any building entrance or enclosed space** to avoid smoke drifting through open doors or windows or people having to pass through a smoking area to access a building. Smoking within faculty apartments is at the discretion of the apartment occupant, but respecting the health and safety precautions, it is the responsibility of smokers to be considerate to and mindful of non-smokers and campus safety. Cigarette waste should be disposed of properly in a safe manner in designated outdoor ashtrays. Fire hazard, campus safety and cleanliness should be considered in disposing of cigarettes and ash. Smokers are held responsible for any violations.

Compliance: Non-compliance of this policy can result in fines and possible disciplinary action. Visitors refusing to comply with the policy shall be asked to leave the campus.

Implementation: Effective implementation of the policy depends upon the courtesy, thoughtfulness, respect, and consideration of all members of the LUMS community; smokers as well as non-smokers. It is the responsibility of all members of the University community to comply with and help implement this policy. Relevant members of the campus community have the responsibility to communicate this policy to new members or visitors, vendors, contractors or other temporary staff visiting the campus.

28.3. Illegal Drugs and Alcoholic Beverages

The following actions specific to contraband drugs, alcoholic beverages and other intoxicating substances shall be considered a serious misconduct and a violation of the Student Code of Conduct at LUMS.

- a. Possession or consumption of opiates, cocaine, marijuana, hashish, alcoholic beverages or other intoxicating substances.
- b. Offering to sell, obtain or facilitate the availability of these substances.
- c. All students who are sitting in a circle of students where these substance (referred to in 'a') are being consumed, are considered as possessing and/or consuming these substances and shall be liable for the punishment of their possession and use accordingly.

29. Sexual Harassment

Harassment is a violation of human rights, is demeaning to human dignity and is unacceptable in a healthy work and academic environment, specifically one in which scholarly pursuit may flourish. LUMS will not tolerate sexual harassment of any member of the LUMS family and will strive through education and deterrence to create an environment free from such behaviour on its premises.

LUMS is guaranteed to be a safe space for all those who inhabit the institution in any capacity. To this end, any harassment, sexual or otherwise, is strictly prohibited under LUMS policy and national law.

Sexual harassment often (but not necessarily) involves a power dynamic, for instance between a supervisor and employee, a teacher and a student, or junior and senior colleagues. These cases may involve an exchange for some benefit or some threat of harm, or they may simply take advantage of the power dynamic to create or condone an environment of harassment. Unfortunately, in such cases, not only is the power dynamic help create a space conducive to harassment, but may also make it more difficult to report.

“Harassment” includes, directly or by implication,

- i. any unwelcome sexual gesture or advance,
- ii. persistent and unwelcome flirting, request for sexual favors, sexual innuendo,
- iii. verbal or written communication (whether electronic or otherwise) of a loaded nature,
- iv. non-consensual physical conduct of a sexual nature including assault, exploitation and sexual violence;
- v. sexually demeaning attitudes;
- vi. stalking;
- vii. causing interference with work performance or creating an intimidating, hostile or offensive campus environment, or
- viii. the attempt or threat to punish the complainant for refusal to comply to requests for sexual favour, or
- ix. the placing of a sexual favour as a condition for employment, promotion, grades or evaluation of a person’s professional engagement in any activity.

Sexual harassment can be physical or psychological in nature. It may be perpetrated using electronic media as well as in person. An aggregation of incidents can constitute sexual harassment even if one of the incidents considered on its own would not constitute harassment.

This list is not exhaustive, and individual behaviours may be found to constitute harassment by the Inquiry Committee using this definition as a guideline.

The committee can be reached with complaints of sexual harassment at harassment@lums.edu.pk or shic@lumsedu.pk. For further details regarding basic terms, policies, and procedures regarding sexual harassment at LUMS, please refer to the Office of Accessibility and Inclusion under the Section 3: Administrative Offices.

30. Disciplinary Examinations and Appeals Committee (DEAC)

The DEAC is responsible to interpret and enforce the academic regulations of the university and to approve exceptions to them as circumstances warrant. The committee is also responsible to take up cases regarding academic standing and readmission.

31. Student Disciplinary Committee (DC)

Matters relating to violation of professional norms are referred to the Disciplinary Committee. When a case is referred to this Committee, it conducts a detailed investigation. After providing a hearing to the student(s) and reviewing the extent of the misconduct, the Committee has the authority to take decisions and impose penalties (including separation from the programme).

Serious violations, such as cheating, plagiarism, use of unfair means, and unprofessional conduct may lead to discontinuation of any financial assistance from LUMS and even separation from the programme.

In case of disciplinary action, all future financial aid may be cancelled, and students will not be allowed to graduate unless they return all previously disbursed financial aid along with accrued interest and penalties for delayed payments, if any. These penalties are applied by the committee after thorough deliberation on a case to case basis.

31.1. Petition

The student(s) against whom a decision has been taken may petition to the Disciplinary Appeals Committee (DAC) within 3 working days for a review of the disciplinary decision.

31.2. DC Decision Implementation

The applicable course grades for students whose cases are under DC review are assigned once the DC decision is communicated to the Office of the Registrar. A HOLD on the issuance of any requested University documents may be placed till the decision is implemented on Zambeel.

31.2.1. Sanctions for Non-Academic Offenses:

For violations of University-wide rules of conduct, members of the community are subject to several kinds of penalties. The applicability and exact nature of each penalty vary on the severity of the offense and its circumstances. For non-academic misconduct, the following sanctions may be imposed:

1. **Warning:** A formal admonition that does not become part of an individual's permanent record, but that may be taken into account in judging the seriousness of any future violation.
2. **Censure:** University censure can be added to any of the other penalties listed above, except warning. Censure indicates the University's desire to underscore the seriousness of the violation and the absence of mitigating circumstances and to convey that seriousness in response to future authorized inquiries about the given individual's conduct or character.
3. **Disciplinary Probation / Loss of privilege of being TA:** A more serious admonition assigned for a definite amount of time, up to two years. It implies that any future violation, of whatever kind, during that time,

may be grounds for suspension, required withdrawal, or in especially serious cases, for expulsion, from the University. Disciplinary probation appears on an individual's permanent record at the University (but not on the transcript) and may be disclosed by the University in response to requests for which the student has given permission.

4. Educational Sanctions, such as letters of apology, educational workshop, essays or research papers.

5. Reimbursement or Fine: This penalty ought to be awarded only in cases involving vandalism, disorderly conduct and alcohol-related infractions which result in damage to University and/or private property of others.

6. Relocation within or removal from university housing: When appropriate to the infraction, particularly in instances involving anti-social behaviour having a serious impact on the residential community, removal from University housing or relocation within University housing may be awarded as a penalty. In the case of a first-year student or a sophomore, this penalty will be imposed only after consultation with the director of the student's residences.

7. Withholding of degree: In cases involving seniors or graduate students, the University may withhold a student's degree for a specified period of time. In such a case, the student may be permitted to remain on campus to complete his or her academic requirements for the degree.

8. Work hours or Community service

9. Behavioural Requirement: Written conditions imposed by the Disciplinary Committee that establish specified requirements for the student or organization. This may include a restraining order, that is, a prohibition to approach a certain individual or to refrain from certain acts.

10. Suspension of privileges

11. Required Withdrawal: Removal from membership in the University for at least the period of time specified by the suspension, with the suspension to continue until certain conditions, stipulated by the Disciplinary Committee, have been fulfilled. These conditions may include restitution of damages, formal apology, or counselling.

12. Suspension or dissolution of a student organization

13. Separation: Removal from membership in, or employment by, the University for a specified period of time, typically a semester or a full academic year.

14. Expulsion from University: Permanent removal from membership in the University without hope of readmission to the community. Disciplinary sanctions will not normally affect the status of financial aid of a student. However, if good conduct conditions are imposed by an external donor as a condition for award of financial aid, then the financial aid award may be curtailed or suspended by the Office of Financial Aid, to comply with the donor's conditions.

31.2.2. Sanctions for Academic Dishonesty

The Disciplinary Committee will select from the following set of penalties when dealing with cases of academic dishonesty, sorted by decreasing severity. A guilty verdict permanently disqualifies a student from holding a Teaching Assistantship at LUMS. Furthermore, a guilty verdict puts a student on probation, and a repeat academic offense will be given harsher penalty.

- a. Expulsion from the university
- b. F in the course + separation for one year¹
- c. F in the course + separation for one semester
- d. F in the course
- e. Zero in the Instrument²+ Double Letter Grade Reduction (DLGR)
- f. Zero in the Instrument + Letter Grade Reduction (LGR)
- g. Zero in the Instrument + Grade Reduction (GR)
- h. Zero in the Instrument³
- i. Warning Letter

31.3. Assignments

Students should stringently follow the rules and procedures regarding written assignments, class preparation, projects, quizzes and examinations for the course.

No discussion is allowed on an assignment, unless specified by the instructor. Any ambiguity regarding the extent of discussion should be cleared with the concerned instructor.

To avoid delays due to network congestion, students should plan well ahead of their assignment submission deadlines.

31.4. Unprofessional Conduct

Plagiarism, cheating and using other unfair means constitute unprofessional conduct. Unfair means include discussions and exchange of all such class notes and written material between the current classes and former students which may subvert the learning process. Exchanging or passing information to other students over the network during lab exams is considered cheating.

Any forms of unfair means are immediately reported by the instructor to the Disciplinary Committee.

Penalty enforced could also take the form of separation from the programme.

31.5. What is Plagiarism?

Plagiarism is the use, without acknowledgement, of the intellectual work of other people, and the act or representing the ideas or discoveries of another as one's own, in written work submitted for assessment. To copy sentences, phrases or even striking expressions without acknowledgement of the source (either by inadequate citation or failure to indicate verbatim quotations) is plagiarism; to paraphrase without acknowledgement is likewise plagiarism. Where such copying or paraphrasing has occurred, the mere mention of the source in the bibliography shall not be deemed sufficient acknowledgement. Each such instance must be referred specifically to its source. Verbatim quotations must be in inverted commas, or indented, and directly acknowledged.

¹ Separation will be effective from the subsequent semester. For graduating students, the degree will be delayed. Summer semester will not count as penalty for one semester separation, but will count in one-year separation

² "Zero in the Instrument" means zero will be given in the specific academic activity in which plagiarism is committed. For example, if a portion of Assignment 3 in a course is plagiarized, zero will be given in Assignment 3, not in all the assignments of that course.

³ In cases where the instrument has very high weightage, zero in the instrument may be a more severe penalty than just grade reduction. In such cases, the Committee may award only grade reduction after the instrument has been graded.

31.5.1. What is a Source?

Sources are published (print or electronic) primary and secondary material, as well as information and opinions, gained directly from other people.

31.5.2. Types of Plagiarism

Plagiarism falls under two broad categories:

- a. Copying an entire document, or part of a document as your entire paper.
- b. Mosaic plagiarism, i.e., mixing the words and ideas of a source with your own, or mixing the words and ideas of two or more sources without acknowledgement.

Plagiarism usually takes one of these forms:

- Uncited idea: passing off someone else's idea as your own.
- Uncited information or data from a source: not acknowledging the source of any fact, figure, event, statistical data or information provided.
- Verbatim phrase or passage that is not quoted: any direct quotation that is not in quotation marks or indented and not referenced at the end of the quotation.
- Misrepresenting evidence: information from a source that has been changed or taken out of context to suit your paper/argument.
- Dual submission: submitting the same paper or parts of a paper to more than one course/instructor.
- Abetting plagiarism: knowingly helping another student to plagiarize by letting him/her copy your paper. Selling a paper to a student, or by writing all or part of a paper for another student.
- Commercial tutoring services: making use of the services of a tutoring school or term paper company to write papers.

31.5.3. How to Avoid Plagiarism

- Do not leave written work until the last day.
- Do not rely mainly on a single source for information or opinion.
- Do not borrow another student's paper.
- Do not write a paper from borrowed notes.
- Do not write the paper with another student.
- Always Backup your work on a hard drive or USB and make a hard copy wherever possible, to avoid problems created by computer failure.
- Always keep your notes and drafts until a paper has been returned.
- If you feel confused or panicked about time, or if you are having personal problems and cannot concentrate, let your instructor and/or teaching assistant know before the submission deadline.
- **Note taking:** When taking notes from a source, always begin by writing down the full bibliographic information (author, title, date of publication, publisher, place of publication, page numbers). Always distinguish between the author's own words and your own points. Do not take notes by carelessly copying and changing a few words. Take notes in a separate word document. Do not mention sources in your bibliography that have not been mentioned in your paper.

31.5.4. Penalties for Plagiarism

The instructor is required to immediately report a potential plagiarism case to the Disciplinary Committee.

Penalties range from a grade reduction to failing grade or separation from the programme.

31.6. Procedure for Handling Grievances

In attempting to resolve any student grievance, it is the obligation of the student to first make a serious effort to resolve the matter with the individual with whom the grievance originated. For example, in the case of a grade related grievance, the student should first talk to the faculty member concerned. The course instructor retains primary responsibility for assigning grades. The instructor's judgment is final unless compelling evidence proves otherwise. In case of non-resolution at this stage, the proper channel to follow is first the faculty advisor assigned to the student, then the department coordinator/Head of Department, and finally the Dean. It should be kept in mind that a grade review can also result in a grade reduction.



Academic Departments & Programme Outlines

SULEMAN DAWOOD SCHOOL OF BUSINESS (SDSB)

Introduction

The Suleman Dawood School of Business (SDSB) was the first school established at LUMS in 1986. Now, over three decades and more than 4500 graduates later, it is ranked as one of the top business schools in the region. SDSB continues to be the first choice of students in South Asia. This is what makes a partnership with SDSB a worthwhile endeavour.

The school offers a variety of programmes including Bachelor's programmes, with majors in Accounting and Finance and Management Science, an intensive full time MBA, a week-end Executive MBA, and a course-based PhD Management.

LUMS-SDSB maintains a close relationship with the business world, which acts as a source of advice and information. This interaction not only helps to keep the curriculum relevant to the needs of business organizations, but also ensures that the students are exposed to the dynamics of the corporate world.

The school aims at providing for the varying educational needs of a culturally diverse and geographically dispersed student body by preparing them academically, personally, and professionally, and providing them access to opportunities to make a difference.

SDSB has research linkages with highly renowned institutes. They have active student and faculty exchange programmes with 38* universities across the world. Adding to the global appeal of the SDSB family is the highly engaged alumni body placed in 49 countries* all over the world. This global networking provides a holistic perspective to the SDSB experience.

Vision

We develop ideas and people to shape business and society

Mission

- a) To advance ethical and thoughtful leadership
- b) To influence practice and policy through knowledge generation
- c) To offer a transformational learning experience

* Refer to OSA website: <https://osa.lums.edu.pk/content/current-linkages>

* Refer to Alumni Connect Portal

SDSB Undergraduate Academic Programmes

Suleman Dawood School of Business (SDSB) offers two undergraduate programmes in the area of Accounting and Finance (ACF) and Management Science (MGS). Learning goals and objectives of SDSB undergraduate programmes are as follows:

General Learning Goals & Objectives

Goal 1 – Effective Written and Oral Communication

Objective: Students will demonstrate effective writing and oral communication skills.

Goal 2 – Ethical Understanding and Reasoning

Objective: Students will demonstrate that they are able to identify and address ethical issues in an organizational context.

Goal 3 – Analytical Thinking and Problem-Solving Skills

Objective: Students will demonstrate that they are able to identify key problems and generate viable solutions.

Goal 4 – Application of Information Technology

Objective: Students will demonstrate that they are able to use current technologies in a business and management context.

Goal 5 – Teamwork in Diverse and Multicultural Environments

Objective: Students will demonstrate that they are able to work effectively in diverse environments.

Goal 6 – Understanding Organizational Ecosystems

Objective: Students will demonstrate that they have an understanding of economic, political, regulatory, legal, technological, and social environment of organizations.

Major Specific Learning Goals & Objectives

Goal 7 (a) – Discipline Specific Knowledge and Understanding (for ACF Majors)

Objective: Students will demonstrate knowledge of key business disciplines and how they interact, including application to real world situations.

Goal 7 (b) – Understanding the “science” behind the decision-making process (for MGS Majors)

Objective: Students will demonstrate ability to analyze a business problem, design and apply appropriate decision-support tools, interpret results and make meaningful recommendations to support the decision-makers.

The Accounting and Finance (ACF) Programme

The four-year B.Sc. (Honours) programme in Accounting & Finance equips students with analytical and practical skills required to excel in the dynamic and competitive business environment of the world today. The programme prepares students with the knowledge and hands-on experience to process and present accounting information according to the needs of the intended users and enables them to use such information for decision making. The finance component of the programme develops students' understanding of finance theory and practices and how financial decisions interface with financial markets to impact firm value. The programme provides students with solid foundations for graduate studies, professional qualifications, and a variety of exciting and challenging careers within accounting and finance.

The Programme has the following key learning objectives:

- Provide students with the theoretical knowledge, analytical tools and understanding of the current practices to handle a variety of accounting and finance functions
- Prepare students with knowledge and hands-on experience to capture accounting transactions, events and conditions, to report them in accordance with the applicable frameworks to internal and external users for decision making and be able to use such information for decision making
- Develop students understanding of financial theory and practice as it relates to financing and allocation of resources among competing opportunities with the aim of creating value
- Develop students' intellectual capacity to engage in critical thinking, problem-solving and reasoning, enabling them to deal with complex business issues by integrating theory with practice
- Develop understanding of the legal, social, political, economic, and technological environments
- Provide students with opportunities to hone personal and interpersonal skills, including effective communication to enable them to develop as independent, confident and reflective individuals who are capable of taking initiative, when working in and/or leading teams
- Develop students who can appreciate the importance of sustainable and ethical practices and play their role as socially responsible individuals within the local as well as global community

Academic Year

The academic year comprises of two regular semesters,

- Fall Semester
- Spring Semester

Each semester is of fourteen (14) teaching weeks' duration with 5 days per week, ensuring 70 days of academic activity per semester, excluding gazetted holidays and final exams . The Fall semester begins in mid-August and lasts through late December, while the Spring semester is from mid -January through late May.

Programme Structure - Accounting & Finance (ACF)

Accounting and Finance – Table 1

Accounting & Finance	Credit Hours	No. of Courses
Graduation Requirements	130 – 132	43
University Core	8	3
University Distribution	23	7
Out-Group Distribution	9	3
In-Group Distribution	12-14	4
ACF Major Requirements	74	24
Business Core	37	12
ACF Major Core	18	6
ACF Internship	04	1
ACF Major Electives	12	4
University Free Electives	30	10

University Core: 8 Credit hrs. [3 Courses]

Kindly refer to *Section 1: Undergraduate Programme Policies and Regulations (Policy 3.2)*

University Distribution: 23 Credit hrs. [7 Courses]

ACF – Table 2

Group	In-Group	Out-Group
ACF	ECON, LAW, MGS* Courses	HSS, SSE Courses

**MGS courses are represented through DISC prefixes, except for DISC 203 course which is an Outgroup.*

Out-Group Distribution: 09 Credit hrs. [3 Courses]

ACF – Table 3

Code	Course Title	Credits
MATH 101	Calculus I	3
MGMT 252	Logic & Critical Thinking	3
DISC 203	Probability & Statistics	3
	Total	9

Only the above-specified courses will be considered to satisfy the outgroup distribution bin requirements for this programme.

In Group Distribution: 12-14 Credit hrs. [4 Courses]**ACF – Table 4**

Code	Course Title	Credits
MECO 111	Principles of Microeconomics	3
MECO 121	Principles of Macroeconomics	3
ECON/LAW	ECON/LAW/MGS* Courses	3/4
ECON/LAW	ECON/LAW/MGS* Courses	3/4
Total		12-14

**MGS courses are represented through DISC prefixes, except for DISC 203 course which is an Out-group. MECO 111 & 121 courses are equivalent to ECON 111 & 121 courses.*

Business Core: 37 Credit hrs. [12 Courses]**ACF – Table 5**

Code	Course Title	Credits
ACCT 100	Principles of Financial Accounting	3
ACCT 130	Principles of Management Accounting	3
DISC 112	Computer & Problem Solving	4
DISC 212	Introduction to Management Science	3
FINN 100	Principles of Finance	3
MGMT 142	Principles of Management	3
MGMT 212	Business Communication	3
MGMT 242	Business Ethics & Corporate Social Responsibility	3
MGMT 260	Business Law	3
MGMT 400	Strategic Business Management	3
MKTG 201	Principles of Marketing	3
ORSC 201	Organizational Behaviour	3
Total		37

ACF Major Core: 18 Credit hrs. [6 Courses]

The ACF major core courses constitute of **18 credit hours** as part of the requirements.

ACF – Table 6

Code	Course Title	Credits
ACCOUNTING		
ACCT 220	Corporate Financial Reporting I	3
ACCT 250	Auditing	3
ACCT 320	Corporate Financial Reporting II	3
ACCT 370	Applied Taxation	3

FINANCE		
FINN 200	Intermediate Finance	3
FINN 400	Applied Corporate Finance	3
	Total	18

ACF 494 – Internship: 4 Credit hours [Mandatory]

ACF internship (6-8 weeks) is a mandatory degree requirement for all ACF students and students get four semester credit hours for this internship. **A minimum of 6 weeks’ duration is required to complete the internship requirement and partial credit will not be given.** Students will require prior approval regarding the nature of the internship from the ACF Internship Coordinator before taking it up.

The pursuit of an internship is a serious responsibility. During their interaction with the host organizations, students represent the Suleman Dawood School of Business as well as themselves. Their conduct must be representative of the values and norms of Suleman Dawood School of Business. Students are expected to adhere to normal working hours and be extremely attentive towards office timings, organizational norms and the quality of output required by their host organizations.

At the end of the internship, students are required to submit a written report documenting the whole learning experience as thoroughly as possible. It gives them confidence that they have actually made the best of this opportunity, but it also gives them a chance to reflect on their experiences in a more structured manner. Additional guidelines on the required content of the report is provided to students through the LMS.

The report will play a significant role in determining the pass/fail grade for the internship and must be submitted within a week of the internship ending. The report should not exceed 3500 words.

Eligibility Criteria:

The eligibility criteria for the ACF internship is as follows:

1. Minimum eligible CGPA for the said internship is 2.5 or above upon the closure of an academic year (Sophomore/Junior/Senior year).
2. Must have passed CFR I (ACCT 220) course.

ACF Electives: 12 Credit hrs. [4 Courses]

ACF majors are required to take **four elective** courses (12 credit hours); these courses must be taken from either the accounting or finance stream or a combination thereof. Each elective course is of **3 credit hours**. It is upon the students to decide which electives they need to take, keeping in mind that **4 courses** in total are to be completed from either/both streams.

ACF – Table 7

ACCT/FINN 1	3
ACCT/FINN 2	3
ACCT/FINN 3	3
ACCT/FINN 4	3
Total	12

ACF – Table 8

FINANCE	
CODE	COURSE TITLE
ACF 491	Senior Project in Accounting & Finance
FINN 222	Introduction to Mathematics of Finance
FINN 242	Islamic Capital Markets & Instruments
FINN 321	Econometrics
FINN 326	Financial Risk Management
FINN 341A	Financial Institutions & Markets
FINN 353	Investments
FINN 372	Actuarial Sciences and Insurance
FINN 383	Capital Markets & Corporate Governance
FINN 402	Commercial Banking
FINN 403	Financial Modelling
FINN 411	International Finance
FINN 422	Quantitative Finance
FINN 441	Islamic Banking and Finance
FINN 453	Financial Derivatives
FINN 454	Portfolio Management
FINN 455	Fixed Income Securities
ACCOUNTING	
CODE	COURSE TITLE
ACCT 202	Theory & Concepts of Accounting – Islamic Perspective
ACCT 302	Accounting for Islamic Financial Institutions
ACCT 331	Strategic Management Accounting & Control Systems
ACCT 352	Advanced Auditing
ACCT 411	Applied Financial Analysis
ACCT 482	Governance, Risk & Compliance

University Free Electives: 27 Credit hrs. [09 Courses]

The University free electives are to be taken from any area of specialization including ACCT, ENGG, FINN, MGMT, MKTG, ORSC, ECON, MATH, HSS, LAW, BIO, PHY, CS, SCI, SSE etc.

ACF – Table 9

UFE 1	3
UFE 2	3
UFE 3	3
UFE 4	3
UFE 5	3
UFE 6	3
UFE 7	3
UFE 8	3
UFE 9	3
UFE 10	3
Total	30

ACF Programme Duration

The normal duration of the BSc ACF programme is four years. A student can, however, remain enrolled in the programme for a maximum of six consecutive calendar years from the date of admission to LUMS as a fresh candidate.

IMPORTANT: Please note that due to the highly structured nature of the Accounting & Finance major, students are required to take the courses in the assigned sequence as mentioned in the Sample Four Year Plan.

The ACF Programme

Graduation Requirement		130 Credit Hours
University Core		8 Credit Hours (3 Courses)
University Distribution	In Group	14 Credit Hours (4 Courses)
	Out-Group	09 Credit Hours (3 Courses)
	Total	23 Credit Hours (7 Courses)
Major Requirement	Business Core	37 Credit Hours (12 Courses)
	Major Cores	22 Credit Hours (6 Courses, Internship)
	Major Electives	12 Credit Hours (4 Courses)
	Total	71 Credit Hours (22 Courses, Internship)
Free Electives*		30 Credit Hours (10 Courses) *

Sample Four Year Plan** (SDSB 2024)

Codes	Cours	Credits	Codes	Course	Credits
First Year Fall			First Year Spring		
<u>SS 100</u>	<u>Writing & Communication</u>	<u>4</u>	<u>SS 101</u>	<u>Islamic Studies</u>	<u>2</u>
MATH 101	Calculus I [Out-group]	3	<u>SS 102</u>	<u>Pakistan Studies</u>	<u>2</u>
MECO 111	Principles of Microeconomics [In-group]	3	MECO 121	Principles of Macroeconomics [In-group]	3
ACCT 100	Principles of Financial Accounting	3	DISC 112	Computer & Problem Solving	4
MGMT 142	Principles of Management	3	FINN 100	Principles of Finance	3
				<i>University Free Elective 1</i>	3
Total		16	Total		17
Sophomore Fall			Sophomore Spring		
DISC 203	Probability & Statistics [Out-group]	3	MGMT 252	Logic & Critical Thinking [Out-group]	3
ACCT 130	Principles of Management Accounting	3	ACCT 250	Auditing	3
ACCT 220	Corporate Financial Reporting I	3	ACCT 320	Corporate Financial Reporting II	3
FINN 200	Intermediate Finance	3	DISC 212	Introduction to Management Sciences	3
MGMT 212	Business Communication	3		<i>University Free Elective 3</i>	3
	<i>University Free Elective 2</i>	3		<i>University Free Electives 4</i>	3
Total		18	Total		18
Junior Fall			Junior Spring		
MKTG 201	Principles of Marketing	3		<i>ECON/LAW/MGS [In-group]</i>	4
ORSC 201	Organizational Behaviour	3		<i>ECON/LAW/MGS [In-group]</i>	4
	<i>ACF Major Elective 1-ACCT/FINN</i>	3	FINN 400	Applied Corporate Finance	3
ACF 494	ACF Internship	4		<i>ACF Major Elective 2-ACCT/FINN</i>	3
	<i>University Free Elective 5</i>	3		<i>ACF Major Elective 3-ACCT/FINN</i>	3
	<i>University Free Elective 6</i>	3	Total		17
Total		19			
Senior Fall			Senior Spring		
MGMT 260	Business Law	3	MGMT 242	Business Ethics & CSR	3
MGMT 400	Strategic Business Management	3		<i>University Free Elective 8</i>	3
ACCT 370	Applied Taxation	3		<i>University Free Elective 9</i>	3
	<i>ACF Major Elective 4-ACCT/FINN</i>	3		<i>University Free Elective 10</i>	3
	<i>University Free Elective 7</i>	3	Total		12
Total		15			

*The number of courses taken towards these requirements will vary according to the course credit hour which can be of 3 or 4

**The sample plan is a suggested roadmap for timely completion of ACF programme requirements. All courses except ACCT 250 & 320, DISC 112, and MECO 111 & 121 are usually offered on a recurring basis in an academic year (Fall and Spring), hence, students may take them any time as per availability during the recommended year.

<u>University Core</u>	University Distribution	Business Core	Major Core	Major Elective	<i>University Free Elective</i>
Underline	Regular	Bold and Underline	Bold	Bold & Italic	Italic

The Management Science (MGS) Programme

The four-year BSc (Honours) in Management Science programme (MGS) is designed to develop students with a strong foundation in decision methods and data analytical techniques in business management. Students will learn to apply these concepts and techniques in providing new insights and improving operations and managerial decision-making processes across various business functions. A strong technical foundation will allow students the opportunity to pursue graduate studies or a professional career involving the application of business and data analytical skills.

The Programme has the following key learning objectives:

- Develop students with strong problem solving and analytical skills.
- Develop students with a broad technical skill set and the ability to critically analyze problems and apply necessary tools to support the decision-making processes.
- Develop students with an understanding of the modern business environment so that they can appreciate the importance of business and data analytics across various business functions, such as marketing, operations, HR, finance and accounting.
- Develop students' intellectual capacity to engage in critical thinking, problem-solving and reasoning, enabling them to deal with complex business issues by integrating theory with practice.
- Develop understanding of the legal, social, political, economic, and technological environments.
- Provide students with opportunities to hone personal and interpersonal skills including effective communication to enable them to develop as independent, confident and reflective individuals who are capable of taking initiative, working in and leading teams.
- Develop students who can appreciate the importance of sustainable and ethical practices and their role as socially responsible individuals within the local as well as global community.

Programme Structure – Management Science (MGS)

MGS – Table 1

Management Science	Credit Hrs.	# of Courses
Graduation Requirements	130	43
University Core	8	3
University Distribution	23	7
Out-Group Distribution	9	3
In-Group Distribution	14	4
MGS Major Requirements	71	23
Business Core	37	12
MGS Major Core	19	6
MGS Major Electives	15	5
University Free Electives	30	10

University Core: 8 Credit hrs. [3 Courses]

Kindly refer to *Section 1: Undergraduate Programme Policies and Regulation (Policy 3.2)*

University Distribution: 23 Credit hrs. [7 Courses]

MGS – Table 2

Group	In-Group	Out-Group
MGS	ECON, LAW, ACF* Courses	HSS, SSE

**Any course with an ACCT or FINN prefix can be used to fulfil this requirement, except for those ACCT/ FINN courses that are part of the business core.*

Out-Group Distribution: 09 Credit hrs. [3 Courses]

MGS – Table 3

Code	Course Title	Credits
MATH 101	Calculus I	3
MGMT 252	Logic & Critical Thinking	3
DISC 203	Probability & Statistics	3
	Total	09

Only the above-specified courses will be considered to satisfy the outgroup distribution bin requirements for this programme.

In-Group Distribution: 12-14 Credit hours [4 Courses]

MGS – Table 4

Code	Course Title	Credits
MECO 111	Principles of Microeconomics	3
MECO 121	Principles of Macroeconomics	3
ECON/LAW	ECON/LAW/ACF* Course	3/4
ECON/LAW	ECON/LAW/ACF* Course	3/4
	Total	12-14

**Any course with an ACCT or FINN prefix can be used to fulfil this requirement, except for those ACCT/ FINN courses that are part of the business core.*

Business Core: 37 Credit hrs. [12 Courses]

MGS – Table 5

Code	Course Title	Credits
ACCT 100	Principles of Financial Accounting	3
ACCT 130	Principles of Management Accounting	3
DISC 112	Computer & Problem Solving	4
DISC 212	Introduction to Management Science	3
FINN 100	Principles of Finance	3

MGMT 142	Principles of Management	3
MGMT 212	Business Communication	3
MGMT 242	Business Ethics & Corporate Social Responsibility	3
MGMT 260	Business Law	3
MGMT 400	Strategic Business Management	3
MKTG 201	Principles of Marketing	3
ORSC 201	Organizational Behaviour	3
Total		37

MGS Major Core: 16 Credit hrs. [6 Courses]

The MGS major core courses consists of **19 credit hours** as part of the requirements.

MGS – Table 6

Code	Course title	Credits
DISC 231	Operations Management	3
DISC 320	Qualitative & Quantitative Methods in Business	3
DISC 321	Decisions Analysis	4
DISC 322	Optimization Methods in Management Science	3
DISC 323	Decision Behaviour	3
DISC 420	Business Analytics	3
Total		19

MGS Elective Courses: 15 Credit hrs. [5 Courses]

MGS majors are required to take five electives (15 credit hours); as a mix of Finance, Accounting, Productions, Operations Management, Marketing, Human Resource Management etc.

The mix is such that students are required to take “**TWO COURSES**” from the Accounting, Finance, Economics, Organizational Sciences & Marketing Stream and “**THREE COURSES**” from the Operations Research/Information Technology & Mathematics Stream. It is upon the students to decide which electives they need to take; keeping in mind that **FIVE COURSES** are to be completed in totality from the two bins. Students will have the option to complete their MGS major electives through any of the below mentioned combinations;

- 1) Five MGS electives
- 2) Four MGS electives + SPROJ
- 3) Four MGS electives + Internship
- 4) Three MGS electives + SPROJ + Internship

Following is the list of courses across different functional areas that can be taken to complete the MGS major electives requirement.

MGS – Table 7

BIN 1	
ACCT/FINN/ECON/ORSC/MKTG	
Code	Accounting, Finance & Economics
FINN 326	Financial Risk Management

FINN 327	Financial Econometrics I
FINN 321/ECON 330	Econometrics
FINN 353/ECON 363	Investments/Economics of Investment & Finance
FINN 454	Portfolio Management
FINN 325/ECON 334	Time Series Econometrics
ECON 368	Applied Time Series Finance
FINN 422/ECON 461	Quantitative Finance
FINN 441	Islamic Banking & Finance
Code	Organizational Behaviour and Marketing
DISC 331	Project Management
MGMT 373	Personal Effectiveness
MGS 492	Senior Project in General Management
MGS 493	General Management Internship
MKTG 332	Consumer Behaviour
MKTG 392	Brand Management
MKTG 324	Integrated Marketing Communications
MKTG 302	New Media Technologies in Marketing
ORSC 341	Human Resource Management
BIN 2	
Operations Research/Information Technology/Mathematics	
Code	Operations Research
DISC 324	Simulation Modelling and Analysis
DISC 325	Business Data Management
DISC 326	Data Science for Decision Making
DISC 333	Supply Chain & Logistics Management
DISC 335	Transportation & Logistics Management
DISC 336	Production Models
MGS 491	Senior Project in Management Science
MGS 494	Management Science Internship
MKTG 343	Marketing Models
MKTG 344	Data Driven Marketing
ECON 233	Introduction to Game Theory
ECON 262	Mathematical Applications in Economics
ECON 435/MATH 433	Advanced Game Theory
Code	Information Technology
Programming	
CS 200	Introduction to Programming
CS 201	Programming in X
CS 300	Advanced Programming
Algorithms	
CS 210	Discrete Mathematics
CS 310	Algorithms
CS 510	Design and Analysis of Algorithms
CS 511	Advanced Algorithms

Databases	
CS 202	Data Structures
CS 340	Databases
CS 360	Software Engineering
CS 432	Introduction to Data Mining
CS 536	Data Mining
Mathematics	
MATH 343	Optimization Techniques
MATH 344	Numerical Analysis
MATH 432	Stochastic Processes
MATH 439	Applied Probability
MATH 442	Mathematics for Finance
MATH 447	Financial Engineering
MATH 462	Dynamic Systems

Students will also have the option to work on a Senior Year Project (SPROJ) and/or complete a Semester - Long Internship to fulfil the requirement for Management Science electives.

Students will get **three or four** credits for the SPROJ. The nature of the research will determine which bin the SPROJ would suffice. The case for the SPROJ assessment is pre-evaluated by the MGS Coordinator equivalent to a course load branching out from the ACCT/FINN/General Management or Operations Research stream.

Similarly, internship is a good way of getting practical and hands on experience and is **OPTIONAL**. Students will get three credits for the Internship and functional area of Job will determine the bin where it would suffice (either in the ACCT/FINN/General Management or Operations Research stream. Students are required to get prior approval from the MGS Internship Coordinator before taking up the internship.

MGS – Table 8

MGS Major Elective 1	3
MGS Major Elective 2	3
MGS Major Elective 3	3
MGS Major Elective 4	3
MGS Major Elective 5	3
Total	15

University Free Electives: 30 Credit hrs. [10 Courses]

The free electives are to be taken from any area of specialization including ACCT, ENGG, FINN, MGMT, MKTG, ORSC, ECON, MATH, HSS, LAW, BIO, PHY, CS, SCI etc.

MGS – Table 9

UFE 1	3
UFE 2	3
UFE 3	3
UFE 4	3

UFE 5	3
UFE 6	3
UFE 7	3
UFE 8	3
UFE 9	3
UFE 10	3
Total	30

MGS Programme Duration

The normal duration of the BSc MGS programme is four years. A student can, however, remain enrolled in the programme for a maximum of six consecutive calendar years from the date of admission to LUMS as a fresh candidate.

IMPORTANT: Please note that due to the highly structured nature of the Management Science major, students are required to take the courses in the assigned sequence as mentioned on the next page in the Sample Four Year Plan.

The Management Science (MGS) Programme

Graduation Requirement		130 Credit Hours
University Core		8 Credit Hours (3 Courses)
University Distribution	In Group	14 Credit Hours (4 Courses)
	Out-Group	09 Credit Hours (3 Courses)
	Total	23 Credit Hours (7 Courses)
Major Requirement	Business Core	37 Credit Hours (12 Courses)
	Major Cores	19 Credit Hours (6 Courses)
	Major Electives	15 Credit Hours (5 Courses)
	Total	71 Credit Hours (23 Courses)
Free Electives*		30 Credit Hours (10 Courses) *

Sample Four Year Plan** (SDSB 2024)

Codes	Course	Credits	Codes	Course	Credits
First Year Fall			First Year Spring		
<u>SS 100</u>	<u>Writing & Communication</u>	4	<u>SS 101</u>	<u>Islamic Studies</u>	2
MATH 101	Calculus I [Out-group]	3	<u>SS 102</u>	<u>Pakistan Studies</u>	2
MECO 111	Principles of Microeconomics [In-group]	3	MECO 121	Principles of Macroeconomics [In-group]	3
<u>ACCT 100</u>	<u>Principles of Financial Accounting</u>	3	<u>DISC 112</u>	<u>Computer & Problem Solving</u>	4
<u>MGMT 142</u>	<u>Principles of Management</u>	3	<u>FINN 100</u>	<u>Principles of Finance</u>	3
				<i>University Free Elective 1</i>	3
Total		16	Total		17
Sophomore Fall			Sophomore Spring		
DISC 203	Probability & Statistics [Out-group]	3	MGMT 252	Logic & Critical Thinking [Out-group]	3
<u>ACCT 130</u>	<u>Principles of Management Accounting</u>	3	<u>DISC 231</u>	<u>Operations Management</u>	3
<u>DISC 212</u>	<u>Introduction to Management Science</u>	3	<u>MGMT 212</u>	<u>Business Communication</u>	3
<u>MKTG 201</u>	<u>Principles of Marketing</u>	3		<i>University Free Elective 2</i>	3
<u>ORSC 201</u>	<u>Organizational Behaviour</u>	3		<i>University Free Elective 3</i>	3
				<i>University Free Electives 4</i>	3
Total		15	Total		18
Junior Fall			Junior Spring		
	<i>ECON/LAW Elective [In-group]</i>	4		<i>ECON/LAW Elective [In-group]</i>	4
DISC 320	Qual. & Quant. Methods in Business	3	DISC 323	Optimization Methods in Mgmt. Science	3
DISC 321	Decision Analysis	4	DISC 322	Decision Behaviour	3
	<i>University Free Elective 5</i>	3		MGS Major Elective 1	3
	<i>University Free Elective 6</i>	3		<i>University Free Elective 7</i>	3
Total		17	Total		16
Senior Fall			Senior Spring		
<u>MGMT 260</u>	<u>Business Law</u>	3	<u>MGMT 242</u>	<u>Business Ethics & CSR</u>	3
<u>MGMT 400</u>	<u>Strategic Business Management</u>	3		MGS Major Elective 3	3
DISC 420	Business Analytics	3		MGS Major Elective 4	3
	MGS Major Elective 2	3		MGS Major Elective 5	3
	<i>University Free Elective 8</i>	3		<i>University Free Elective 10</i>	3
	<i>University Free Elective 9</i>	3			
Total		18	Total		15

*The number of courses taken towards these requirements will vary according to the course credit hours which can be of 3 or 4

**The sample plan is a suggested roadmap for timely completion of MGS programme requirements. All courses except DISC 112, and MECO 111 & 121 are usually offered on a recurring basis in an academic year (Fall and Spring), hence, students may take them as per availability at any time during the recommended year.

<u>University Core</u>	University	<u>Business Core</u>	Major	Major	University Free
<u>Underline</u>	Distribution	<u>Bold and</u>	Core	Elective	<i>Elective</i>
	Regular	<u>Underline</u>	Bold	<i>Bold & Italic</i>	<i>Italic</i>

MGS 493/494 - Internship: 3 Credit hrs. [Elective]

Below are the guidelines that drives the internship programme for the Management Science (MGS) major at Suleman Dawood School of Business (SDSB). Internship is recommended as an important practical experience, allowing students the opportunity to synthesize their in-class academic learning with real world organizational practice. As an added advantage, the summer internship will give MGS students the advantage of the job market with some work experience related to their major under their belts.

Background Considerations

1. Compensation (credits and payment)

The student compensation for the MGS internship (credit hour terms) be fixed at **3 credit hours** (equivalent to one undergraduate course, and thereby requiring an equivalent amount of effort). Monetary payments by organizations are left at their discretion.

2. Internship Objectives

- Apply business concepts and decision-making tools to real-world scenarios/problems
- Increase proficiency in a specific business: such as human resources management, operations management, marketing, accounting, economics, finance, etc.
- Develop and improve business skills in communication, technology and teamwork.
- Observe (and possibly participate) in business operations and decision-making.
- Meet professional role models and potential mentors who can provide guidance, feedback, and support.
- Expand network of professional relationships and contacts.
- Develop a solid work ethic and professional conduct, as well as a commitment to ethical conduct and social responsibility.

3. Target Organizations

Given the unique skillset acquired by MGS scholars by their Junior year, placements are made at organizations where students are able to apply some of the tools they have learnt during the course of their studies. The Career Services Office (CSO) will match identified host organizations to student profiles and their work preferences. However, students are also encouraged to bring in their own contacts in prospective organizations for the purpose.

4. Time of Internship and Credit

The internship will take place during the student's Junior or Senior year during the Summer break. The internship is 6-8 weeks long, and **3 credits** are awarded for its completion. As a rule of thumb, **at least six weeks** of continuous work at the host organization's premises (or recommended site) is given a full credit. Partial credit will not be given. Students are expected to adhere to normal working hours and be extremely attentive towards office timings, organizational norms and the quality of output required by their host organizations. The pursuit of an internship is a serious responsibility. During their interaction with the host organizations, students represent the Suleman Dawood School of Business as well as themselves. Their conduct must be representative of the values and norms of Suleman Dawood School of Business.

5. Assurance of Continued Learning during the Internship

In order to ensure that an internship continues as a learning situation and that the intended relationship between intern and host organization continues during the internship tenure,

- (i) The student is encouraged to seek the faculty sponsor's assistance if any problems of communication arise or if he/ she finds that learning opportunities are being reduced or restricted.
- (ii) A number of reports are required to be submitted by the student to the CSO at the start of the internship, during the internship and after its completion. Details are provided by the Programme Coordination Office (PCO) - SDSB. Internships will not be given credit without the submission of these deliverables.
- (iii) The faculty sponsor/ CSO may make site visits during the course of the internship, and feedback is obtained by work supervisors periodically.

Reports Required:

1. Internship Proposal/Design Statement

Students are expected to be partially responsible for the design of the internship undertaking. It is recommended that students prepare a short 'internship design statement' which should be prepared in tandem with their supervisor at the host organization. This is submitted alongside the one-week report.

The proposal should contain the following elements:

- Career goal of student
- Learning objectives for the internship (the "Internship Objectives" in I-2)
- Description of place of internship (and on-site work, if any) and functional area within which placement has been done.
- Name, designation and contact of supervisor.
- Expected work to be completed during the internship.
- The student's preparation for the internship (such as related coursework covering the industry, if any)
- Additional comments, if any.

2. Approval Procedures: Internship output and evaluation for credits

At the end of the internship, students are required to write an 8-10-page report (1.5 spaced, 11 font size, printed on both sides, with annexures), assessing one or more aspect of the organization that they were exposed to and their detailed output therein. The report must clearly state the nature of work undertaken, lessons learnt, and the output given to the host organization. This report must be routed to the faculty supervisor through the CSO Office within a week of the internship ending.

Students must also submit a concise one-page summary of their experiences within the organization. This is a separate document from the internship report. This would include a personal evaluation of whether they felt this was a worthwhile experience, and how it could be improved. This is routed to the faculty supervisor through the CSO Office as well.

The host organization will also be requested to fill an evaluation form giving feedback on student behavior, the quality of the output and professionalism and whether the internship met their own expectations.

Partial credit for incomplete internships will not be given. Credits are given once the faculty supervisor is satisfied with the internship visit/call, host organization's evaluation of the student and the final internship report.

General Rules and Policies

Senior Year Project (SPROJ) / Independent Study (IS) Policy

Please refer to page Policy No. 8 under Section 1: Undergraduate Programme Policies and Regulations for university wide policies applicable to Directed Course Work.

Senior Projects and Independent Studies are intended to provide students with an opportunity to integrate and apply what they have learned from the courses in their major programmes. It should demonstrate an ability to formulate an original research question/problem along with the appropriate research methods to investigate the question posed. The study should report findings and explain their implications and ramifications in detail.

The form of the Senior Project /Independent Study varies with the substance of the student's major programme and the student's specific learning goals

Some forms which a Senior Project/ Independent Study may take are as follows:

- An original Research Project using a method such as surveys or interviews.
- An original research question about an organization's management or financial reporting practices.
- A critical review of the scholarly literature on some aspect of the student's major field.
- An analysis of a company's financial or management process.
- A paper based on an internship with a business or a non-profit organization, detailing or critically analyzing some management issues.

These examples are mere suggestions for guidance purpose only and are not meant to be exhaustive in any way. Students are encouraged to be creative and should come up with a project that will contribute to the existing body of knowledge.

The Senior Project / Independent Study must be completed in the student's last year / Senior year.

The process of planning a Senior Project/ Independent Study should begin by the start of the semester prior to the semester in which the student is registering for the project. However, it is useful to start thinking about it even earlier. To enhance learning outcomes students should work closely with faculty supervisors in the process of planning and carrying out the project as detailed below.

- 1. Select a topic and the potential supervisor** at least one semester before students plan to begin working on the project. Selecting a topic will involve three elements: choosing the subject students will be working on, the approach to the subject, and the form the project will take. The process of

selecting a topic should involve consultation with the proposed supervisor. Full time, Visiting & Adjunct faculty members can supervise Senior Projects and Independent Studies at SDSB.

- 2. Write a proposal** before the semester in which students plan to complete the project. The project proposal explains what the project is all about, how students plan to carry it out, and what students hope to learn by doing it. The proposal should specify:

The questions students want to answer or problems they want to address

- How students plan to address them, i.e., the form their project will take
- The methods that students plan to use, e.g., statistical analysis, archival research, textual analysis, qualitative research, etc.
- Materials students intend to use (a bibliography will often answer this question)
- The courses & experiences that have prepared students to undertake this project
- The area that students think this proposal should be counted towards.
- The number of credit hours' students are hoping to gain from this Senior Project / Independent Study
- A rough timeline for the completion of the project
- The scope of work to be undertaken by each member of the group

- 3. Work with the supervisor to:**

- i) make any revisions needed to clarify the project proposal, and
- ii) identify an area of ACF OR MGS where the project should be ideally counted towards.

- 4. Approval from the department:**

The department will review the proposal and if needed call a meeting to discuss the proposal. Based on the results of this meeting, the department will finalize the following:

- i) The number of credit hours (3 to 4) for Senior Project spanned over a semester and 6 for a year (1 to 2) for Independent Studies.
- ii) Any suggestions on scope of the work.

- 5. Registration for Directed Course Work:** The students will register for the Directed Course Work through the online module from their Zambeel self-service. The DCW requests will be sent to the Undergraduate Programme Coordination Office Coordinator and the respective supervising faculty. After their approval, the requests will be forwarded to RO for further processing.

The total limit for DCW credit hours is 12 including internship credits.

Approval is subject to the following criteria being met:

	Senior Project	DRP	Independent Study
Number of Students	2 – 6	1 – 5	1
Number of Credit Hours	4 – 6	1 – 2	1 – 2
Supervisor's Approval	Yes	Yes	Yes
Department's Approval	Yes	Yes	Yes
RO's Approval	Yes	Yes	Yes
Conduction Year	Senior Only	Juniors or Seniors	Senior only
Grading	A+ to F	Pass/Fail	Pass/Fail

It is expected that the Directed Course Work will require significant work from the students to justify the credit units assigned to the project. In general, same grades are given to the entire group. However, at the discretion of the instructor, different grades may be awarded to group members based on objective evidence of differential performance. The instructor may use presentation, viva or other such means along with the written report to assess the students' performance.

For an SPROJ to be counted towards **Accounting OR Finance major electives** the main component of the SPROJ should be based on Accounting or Finance which requires due approval by the ACF Programme Coordinator.

For MGS Majors, the nature of the SPROJ undertaken will determine which bin (BIN 1 or BIN 2) it will fall into. The case for the SPROJ assessment is to be pre-evaluated by the faculty supervisor and approved by the MGS Programme Coordinator.

BIN 1 = General Management

BIN 2 = Management Science

Senior Projects can also be counted towards university free electives.

A Directed Research Project/ Independent Study is counted towards university free electives.

Enrollment Status Requirement and Course Load

All ACF/MGS First year students are required to take at least **12-16 credit hours** in a regular semester to maintain full time status. However, in extreme cases i.e. physical/ psychological disability etc., please refer to Section 1: Undergraduate Programme Policies and Regulation (Policy 7).

Major Declaration/Specialization

The SDSB undergraduate batch of 2024 will have the option of declaring their major (either ACF or MGS) at the end of Spring semester of the First year. In case of capacity constraints, some students may not get the major of their preferred choice. The criteria for major allocation is based on the CGPA of the students at the end of Spring semester of the First year.

The students do have the option to revisit their decision of major choice upon the closure of the Sophomore year and are required to apply through the Major Change Form to process the change.

Interschool Transfer Policy - SDSB

Interschool transfers to Suleman Dawood School of Business (SDSB) may be applicable in case of the following two major scenarios:

a. CGPA greater than or equal to 3.5 (CGPA \geq 3.5)*

Students with a CGPA greater than or equal to 3.5 at the end of First/Sophomore year(s) are eligible for a direct transfer to SDSB Undergraduate Programmes (ACF/MGS), based on their given major preference.

b. CGPA greater than or equal to 3.0 but less than 3.5 (CGPA \geq 3.0 and $<$ 3.5)**

Students with a CGPA greater than or equal to 3.0 but less than 3.5 can be considered for a transfer to SDSB Undergraduate Programmes provided the applicant meets the following two conditions:

- *a. Student has taken at least three ACF/MGS courses by the end of First/Sophomore year(s).
- **b. Student meets the criterion mentioned in (B.1) and CGPA weightage is ≥ 3.3 . **CGPA weightage¹** for such cases is calculated by giving 50% weightage to CGPA of all ACF/MGS courses and 50% weightage to CGPA of courses taken at other schools.

If the afore-mentioned criteria (B.1) and (B.2) are fulfilled, then the student with a CGPA greater than or equal to 3.0 but less than 3.5 can be considered for a transfer based on the recommendation of SDSB Undergraduate Programme Committee and approval of the Associate Dean (Academic Programmes).

Notes:

- i) If a student has taken less than three ACF/MGS courses by the end of the First/Sophomore year(s), then policy stated in clause (A) shall be applicable.
- ii) Students having a CGPA of less than 3.0 at the end of the First/Sophomore year(s) are not eligible to apply for a transfer to SDSB Undergraduate programmes.
- iii) The policy guidelines mentioned above only serve as a screening criterion for the potential pool of applicants; and do not provide any guarantee for the interschool transfers to SDSB, since transfers are contingent upon the availability of seats and approval of the SDSB undergraduate committee.

¹Formula for calculation of CGPA Weightage

$[\text{CGPA of Non ACF/MGS Courses} \times 0.5] + [\text{CGPA of at least three ACF/MGS Courses} \times 0.5]$

Public Management Minor

While the government sector is the largest job provider in Pakistan, there is a considerable lack of quality public management education in the country. Offering a Minor in Public Management gives SDSB a chance to bridge this educational gap and, at the same time, advance its mission to impact the practice of public management

Purpose:

The minor will complement existing majors at LUMS, by providing education and training in managerial, analytical and leadership skills needed, to assume professional roles in public and development sector organizations.

Course and Credit Hours Distribution:

The Minor will consist 18 credits distributed over 6 courses. All University-wide policies pertaining to Minor programmes apply to the Public Management Minor. In addition to those, the following policies will apply to the Minor in Public Management:

1. The following two courses are “Core” courses for the minor:
 - a. MGMT 243 Public Administration
 - b. MGMT 261 Introduction to Policy Analysis

2. The remaining 12 credits for the Minor may be completed by taking a combination of the following elective courses, in accordance with the University policies pertaining to course levels that make up a Minor:
 - a. MGMT 244 Reforming the Public Sector
 - b. MGMT 246 ICT in Government
 - c. MGMT 262 Governance System of Pakistan
 - d. MGMT 263 Contemporary Social Policy Issues in Pakistan
 - e. MGMT 342 Non-profit and Voluntary Organizations
 - f. MGMT 345 Entrepreneurship and Innovation in Education Sector
 - g. MGMT 347 Organizing and Organizations for Social Change
 - h. MGMT 348 Internet Governance and Technology Policy
 - i. EDU 352 Education Policy Analysis
 - j. MGMT 362 Rethinking Policy: Critical Perspectives on Pakistan’s Agricultural Development
 - k. MGMT 364 Women and Public Policy in Pakistan
 - l. MGMT 365 Urban Planning and Development
 - m. MGMT 366/
EDU 362 Monitoring and Evaluation in Public Policy
 - n. MGMT 462 Modern Thought in Social Policy
 - o. MGMT 463 Gender & Global Finance

Computational Finance Minor

The minor in Computational Finance will provide opportunity to students to prepare for higher education in Financial Engineering, Mathematical or Computational finance. Essentially, the students will have the baseline theoretical and empirical knowledge along with hands on expertise in computation, which will serve as entry requirements to specialized master programmes.

Purpose:

The minor will provide students with the theoretical understanding and practical skills to formulate, implement, and evaluate models used by the financial sector to structure transactions, manage risk, and construct investment strategies.

Course and Credit Hours Distribution:

PROGRAMME STRUCTURE (Total Req. 18-24 CR)		
MINOR CORE: Total 7 Credit Hours		
1) Quantitative Finance (with MATLAB)	4 CH	Offered by (SSE)
2) Computational Problem Solving	3 CH	Offered by (SSE)
Orientation: Mathematics + Finance + Computation		
Objective: [Theory (Advanced), Practice (Intermediate)]		

Electives Requirement*: Total 4 courses with minimum 1 course from each skill set		
Financial Modelling	1) Financial Derivatives 2) Portfolio Management 3) Fixed Income Securities	
Data Analysis Tools	1) Introduction to Data Mining 2) Time Series Econometrics 3) Financial Econometrics I 4) Actuarial Sciences and Insurance 5) Numerical Analysis & Simulation (SSE)	
Mathematics	1) Introduction to Mathematics of Finance (with MATLAB) 2) Stochastic Processes I / Advanced Stochastic Processes-1 (SSE) 3) Stochastic Processes-II (SSE)	
SKILL SET ORIENTATION		
Status: Financial Modelling Courses Offered (1,2)	Status: Data Analysis Tools Courses Offered (1,2,3,4)	Status: Mathematics Courses Offered (1, 2)
SKILL SET CONTRIBUTION TOWARDS OBJECTIVES		
Theory + Practice (Advanced)	Practice (Advanced)	Theory (Advanced)

Office of Undergraduate Student Advising SDSB (OUSA - SDSB)

The Office of Undergraduate Student Advising SDSB, aims at providing proactive, prescriptive and developmental advising to the undergraduate students of SDSB from the start of their freshmen year till the time they graduate. The office engages students in a developmental process that helps them clarify and implement individual educational plans consistent with their skills, interests, and values and navigate them in achieving their personal, professional, and educational goals. Our goal is to maximize student retention, facilitate timely graduation and promote holistic student development.

Academic Advisement:

Students are provided the following support and advisement throughout the year:

1. **General Advising:** This advisement caters to general academic and non-academic issues (i.e., academic difficulties, social/personal issues, adjustment issues and minor mental health issues). This advisement is done through appointment or on a walk-in basis.
2. **Semester Planning & Advising:** Students are required to meet their academic advisor at least one month prior to the enrollment for the next semester to discuss semester planning and course selection. Graduating seniors are required to meet their advisor for validation of degree requirements.
3. **Proactive Advising:** Students on warning (with a CGPA 2.50 – 2.00) and probation (with a CGPA below 2.00) are required to meet their academic advisor at least 2 to 4 times a semester. Other students, including readmissions, exchange students or transfers to SDSB from within or outside LUMS are also required to meet their academic advisor for to discuss their graduation plan. Students can meet their academic advisor for advisement on an appointment basis.

To book an appointment with the academic advisor students are required to email at helpdesk-ousa@lums.edu.pk.

Specialized Advisement:

Students are provided support and advisement for the following specific topics:

1. **Major Selection Advising:** Our goal is to assist students with major exploration in order to ensure timely graduation. This advising help students make an informed decision about their major by the end of freshmen year. Students can book their appointments to meet the specialized faculty advisors from the area of Accounting & Finance and Management Science. An Informational session on Major Declaration is also planned once a year. All first-year students and sophomores are required to attend this session.
2. **Career Development and Graduate School Advising:** Career development advisement assists students in matching their academic achievements with their career goals and provides them with a road map to their future. Advisement is also available for students who plan to pursue graduate studies. Specialized Faculty Advisors are available on an appointment basis.

Students can book appointments by sending an email at helpdesk-ousa@lums.edu.pk.

First Year Advising – Peer Advisement and Student Support:

Peer advisement & student support is available for first year students. Our Peer Advisors are students in their junior or senior year at SDSB and undergo a rigorous selection process. They are readily available to provide quality resource information related to curriculum, course planning, advising referrals, university

processes and helping students with adjustment issues at LUMS. First year students are required to meet their assigned Peer Advisors on a mandatory basis (4 meetings per semester). Peer advisors assist with:

1. **Course Enrollment:** During Orientation Week, and subsequently.
2. **Student Support:** They assist students in developing their individual capacity by offering them the required support to alleviate feelings of isolation and disconnection from the university.
3. **University Resource Referrals:** They also act as a guide for freshmen regarding university referrals and resources.

Advisement sessions with Academic Advisors, Specialized Advisors and Peer Advisors are planned throughout the semester for first year students in order to develop a deeper understanding about courses, majors and school policies as given in the student handbook. These sessions also highlight resources available on campus to facilitate students' transition to LUMS. Students can request for meeting appointments by emailing their assigned Peer Advisor. For general academic concerns students can also have a conversation within their Peer Advising Online Support Group.

Online Advising Helpdesk Support:

The Online Advising Helpdesk is for all advising related queries / concerns and scheduling of advising appointments. For any kind of queries related to your academic management, enrollment, major selection/change issues, section change issues, and career counseling, you can drop an email at helpdesk-ousa@lums.edu.pk. Students will receive a reply from the relevant advisor with advice or possible solutions to their problems.

Advising Resources: SDSB's Advising Website will help students in getting detailed information about advising processes and resources which would be helpful for the students throughout their stay at LUMS.

For Appointments and Student Queries: helpdesk-ousa@lums.edu.pk

Website: <https://sdsbadvising.lums.edu.pk>

Office Location: SDSB Building, Ground Floor (left side from the main entrance).

Contact Resources:

<p>Dr. Alnoor Bhimani Dean, SDSB a.bhimani@lums.edu.pk Contact # 0423-5608244</p>	<p>Ms. Atifa Arif Dar Director, Undergraduate Programmes atifa.dar@lums.edu.pk Contact # 0423-5608364</p>
<p>Dr. Syed Aun Raza Rizvi Associate Dean Academics aun.raza@lums.edu.pk Contact # 0423-5608498</p>	<p>Dr Omair Haroon Coordinator, Accounting and Finance Programme omair.haroon@lums.edu.pk Contact # 0423-5608394</p>
	<p>Dr Ussama Yaqub Coordinator, Management Science Programme ussama.yaqub@lums.edu.pk Contact # 0423- 5608577</p>
	<p>Mr. Muhammad Imran Nasim Assistant Manager, Undergraduate Programmes imran.nasim@lums.edu.pk Contact # 0423-5608233</p>
	<p>Ms. Syeda Aroos Nasir Senior Officer, Undergraduate Programmes syeda.nasir@lums.edu.pk Contact # 0423-5608406</p>
	<p>Mr. Bilal Hassan Alvi Officer, Undergraduate Programmes bilal.hassan@lums.edu.pk Contact # 0423-5608000 Ext # 5014</p>
	<p>Ms. Fatima Khalid Assistant Manager - Office of Undergraduate Student Advising (OUSA) fatima_khalid@lums.edu.pk Contact # 0423-5608371</p>

MUSHTAQ AHMAD GURMANI SCHOOL OF HUMANITIES AND SOCIAL SCIENCES (MGSHSS)

The Mushtaq Ahmad Gurmani School of Humanities and Social Sciences is the leading humanities and social sciences programme in the country with an established reputation of producing graduates who have become leaders in understanding and shaping society. Over the decades MGSHSS has earned an international reputation in the field of humanities and social sciences. A community of world-class scholars, the vibrancy of the teaching, the quality of the research and an outstanding curriculum all combine to produce an undergraduate programme of the highest international standards.

At the School we will strive to have our students graduate with the capacity to explore widely and deeply, think creatively and critically, and express ideas clearly and effectively. By realizing their full intellectual and personal potential, students will contribute to the betterment of society in Pakistan and the wider region. MGSHSS aims to nurture individuals to be principled, intellectually engaged, and socially responsible members of society who aspire to change the world around them through inspirational leadership and transformative community participation.

MGSHSS comprises two departments:

- Humanities and Social Sciences, and
- Economics

MGSHSS offers four-year degree programmes in the following majors:

BSc (Honours)

- Anthropology / Sociology
- Economics
- Economics and Mathematics (Joint Major)
- Politics and Economics (Joint Major)
- Political Science

BA (Honours)

- English
- History

In addition to majors, MGSHSS offers Minors in the following disciplines:

- Anthropology / Sociology
- Comparative Literary & Cultural Studies (CLCS)
- Economics
- Gender and Sexuality Studies (GSS)
- History
- English
- Philosophy
- Political Science
- Psychology
- Study of Religion

MGSHSS Core Curriculum

The Mushtaq Ahmad Gurmani School of Humanities and Social Sciences (MGSHSS) has introduced a new Core Curriculum for its undergraduate studies from the class of 2022 onwards. The Curriculum aims to ensure that every student graduating from MGSHSS LUMS with a Bachelor's degree possesses a broad foundation of knowledge and a diverse set of transferable skills. The interdisciplinary nature of the Core will help ensure that students emerge as reflective, empathetic, and historically informed individuals, with an understanding of both global and local current issues.

Based on the LUMS philosophy regarding undergraduate education, the School has created six thematic clusters, from which students are required to take at least one course each over the duration of your degree. These are:

1 st Year	Arts & Humanities Social & Behavioral Sciences STEM
2 nd Year	Contemporary Debates
3 rd & 4 th Years	Great Authors Academic Writing

The Core Curriculum is completed over the course of Bachelor's degree, with three courses in each cluster required in the first year, one course in sophomore year and two courses over junior/ senior years.

In the first year, the students will choose options from Social and Behavioral Sciences, STEM, Arts and Humanities and Writing and Communication (which is currently offered as a University Wide Core). In the second year, the students will choose courses from Contemporary Debates, Islamic Studies and Pakistan Studies (again already offered as University Core). In the third and fourth year, the students will take options from Great Authors and Academic Writing. The Core Curriculum along with the current group of University wide Core Courses add up to 32 credit hours of coursework. The students will still be able to pursue a minor in addition to their respective majors *and* there is ample space to take free electives.

1. All first year students are allowed to enroll in 16 credits ONLY in their first year.
2. Islamic Studies and Pakistan Studies will only be offered for the entering class in the Sophomore year.
3. All students enrolled in Islamic Studies in their respective semesters shall enroll in a contemporary debates course in their sophomore year
4. Majors will be declared in or by the end of the 4th semester of their academic career.
5. Students from Matric system or those who did not take A levels economics MUST take Econ 100. Econ 100 will serve as a Social and Behavioral Sciences course
6. Students with no A levels Mathematics background or from Pre-medical MUST enroll in Pre-calculus. Pre-calculus will serve as a STEM course
7. There are no in-groups for MGSHSS batch 2022 onwards, however, students MUST complete 3 outgroups over the course of 4 years.

FOUR YEAR DEGREE PLAN*

FIRST YEAR		
	Fall (First Semester)	Spring (Second Semester)
Half of the First-year batch will be taking	<ul style="list-style-type: none"> • Writing and Communication • Social and Behavioural Sciences • Arts and Humanities • STEM 	<ul style="list-style-type: none"> • Social and Behavioural Sciences • Arts and Humanities • STEM
Half of the First-year batch will be taking	<ul style="list-style-type: none"> • Social and Behavioural Sciences • Arts and Humanities • STEM 	<ul style="list-style-type: none"> • Writing and Communication • Social and Behavioural Sciences • Arts and Humanities • STEM
	Total Credits= 12-16 ¹	Total Credits= 12-16

¹The CHs will be different for the number of courses taken and the respective CHs of those courses. Students are allowed to enroll in only **16 CHs**.

Please note that the above are mandatory requirements for the first-year students only. The students may enroll in any other introductory level courses (100/200 level courses) to satisfy their remaining credit hour requirements

SOPHOMORE YEAR		
	Fall (Third Semester)	Spring (Fourth Semester)
Half of the Sophomore batch will be taking	<ul style="list-style-type: none"> • Islamic Studies • Contemporary Debates • 2-3 other courses* <p><i>*These courses could range from your 100/200 level major requirements to free electives and/or outgroups</i></p>	<ul style="list-style-type: none"> • Pakistan Studies • 3-4 other courses
Half of the Sophomore batch will be taking	<ul style="list-style-type: none"> • Pakistan Studies • 3-4 other courses 	<ul style="list-style-type: none"> • Islamic Studies • Contemporary Debates • 2-3 other courses* <p><i>*These courses could range from your 100/200 level major requirements to free electives and/or outgroups⁶</i></p>
	Total Credits= 12-20 ²	Total Credits= 12-20

²The CHs will be different for the number of courses taken and the respective CHs of those courses. Students are advised to enroll in 16 CHs, however they can take up to 20 CHs

*Courses that can be taken at any point of student's degree plan outside your school and major. Ideally, they should be taken in the first year or second years

*Please note that this is a sample plan. Apart from university and school core requirements, you have the flexibility to choose your own semester plan which you can customize with the guidance of your academic advisor.

JUNIOR YEAR & SENIOR YEAR		
	Fall	Spring
Junior and Senior Year	<ul style="list-style-type: none"> • Great Authors and/or • Academic Writing • Major Cores • Major Electives 	<ul style="list-style-type: none"> • Great Authors and/or • Academic Writing • Major Cores • Major Electives
	Total Credits= 12-20 ³	Total Credits= 12-20

The students still have the option to take free electives. After they have completed their major cores and major electives, they may choose to take free electives to fulfill their overall degree requirements. Free electives are courses that may be used to fulfill the minor requirements, if the student opts for one, or they can be used to take any course whether part of their major specialization or not. They offer an opportunity to explore different areas of interest.

³The CHs will be different for the number of courses taken and the respective CHs of those courses.

Department of Humanities and Social Sciences

The Humanities and Social Science (HSS) Programme at LUMS provides students with a theoretical framework to examine and develop a better understanding of a complex and interdependent world. It aims to enhance a students' research, analytical, communication and critical thinking skills, so that they are well-suited to pursue a wide range of careers in teaching, public and mental health, counselling, social work, criminal justice, public policy, journalism, and the non-profit sector.

The Department of Humanities and Social Sciences offers the following majors:

- Anthropology/ Sociology
- English
- History
- Political Science

The Anthropology/Sociology Programme

Graduation Requirement: 130 Credit Hours

University Core: 8 Credit Hours

Kindly refer to Section 1: Undergraduate Programme Policies and Regulation (Policy 3.2)

Major Requirements: 52 credit hours (13 Courses)

A student doing a major in Anthropology/Sociology is expected to complete 13 courses in the discipline. Students can achieve this objective through a combination of core and elective courses. The 52 credit hours is spread out as follows:

Major Core Courses: 16 Credit Hours (4 Courses)

Anthropology/Sociology - Table 1

Code	Course Title	Credits
ANTH 100	Introduction to Cultural Anthropology	4
SOC 100	Introduction to Sociology	4

One of the following: ¹

Code	Course Title	Credits
ANTH 320	Qualitative Research Methods	4
Or		
SOC 320	Quantitative Research Methods	4

¹Note that both method courses may be taken as well. In that case, the second method course would be counted as part of the electives

One of the following: ²

CODE	COURSE TITLE	CREDITS
ANTH 310	Classical Theory in Cultural Anthropology	4
Or		
SOC 310	Classical Social theory	4

²Note that both theory courses may be taken as well. In that case, the second theory course would be counted as part of the electives

Major Elective Courses: 36 Credit Hours (9 Courses)

In addition to the Core Courses, students are required to take nine courses from the following electives list, under any of the sub fields of the discipline (this is not an exhaustive list). Of these nine courses, students can take no more than one course at the 100 level, and at least four courses at the 300 or 400 level (of which at least one course has to be at the 400 level). Please note that the electives list may change at any time and the list below will regularly be updated.

Anthropology/Sociology majors will also have the **option** of completing a Senior Project which is equivalent to two courses (8 credit hours) and takes place over two semesters. Students may **not** take a Senior Project to fulfil the **300/400 level major elective requirement**.

Anthropology/Sociology - Table 2

Code	Course title	Credits
ANTH 237	Economic Anthropology: An Introduction	4
ANTH 238	Youth and Globalization	4
ANTH 235	Introduction to Development Studies	4
ANTH 236	Gift of Marcel Mauss: Is Reciprocity a Founding Principle of Society	4
ANTH 246	Political Ecology	4
ANTH 250	Gender and Power	4
ANTH 263	Food and Culture	4
ANTH 265	Parada: Muslim Veiling in South Asia	4
ANTH 266	An Introduction to the Anthropological Study of Kinship	4
ANTH 270	Anthropology of Art	4
ANTH 271	Visual Anthropology and Ethnographic Filmmaking	4
ANTH 276	Ethnography of Social Media	4
ANTH 280	Ethnography of Pakistan	4
ANTH 312	Modernity as a Way of Life	4
ANTH 352	Gender and Development	4
ANTH 360	Anthropology of Religions: Christianity and Islam	4
ANTH 361	Muslim Veiling: The Struggle for Identities in Diasporas	4
ANTH 432	The Anthropology of Globalization	4
ANTH 461	Ritual and Belief: Witchcraft, Magic and Religion	4
ANTH 464	Children of Abraham	4
SOC 223	Sociology of Education	4
SOC 230	Global Cities 1300-2000 A.D.	4

SOC 237	Remaking the Modern World: Technology & Social Change	4
SOC 252	The Scientific Imagination	4
SOC 233	Power, State and Society	4
SOC 235	Sociology of Religions	4
SOC 263	Africa in the World System	4
SOC 271	Deviance and Social Control	4
SOC 292	Masculinities	4
SOC 321	Comparative & International Education	4
SOC 342	Culture, Power and Society	4
SOC 344	Sociology of Intolerance	4
SOC 372	Contention and Rapture	4
SOC 410	Max Weber	4
SOC 412	Political Sociology	4
SOC 432	Colonialism and Colonial Legacies	4
SOC 462	Divided Cities	4
SOC 463	Spatial Politics and Citizenship in Urban Lives	4

In addition to these electives, courses in other streams may also qualify as credit courses for Anthropology/Sociology majors.

Anthropology/Sociology Four Year Sample Plan

As a rule of thumb, students should look to spend their first year taking 100 level courses that introduce them to the broad themes of a discipline. These will include courses such as Introduction to Anthropology, Introduction to Philosophy, Introduction to Political Science, Introduction to Historical Studies, Introduction to Sociology, Introduction to Logic, Human Behaviour etc. These introductory courses must be taken in the first four semesters, so that students can make an informed decision on which major to pursue. Students should also take Writing & Communication in their first year, as solid writing skills will impact many subsequent courses that have a writing component to them. From the second year, 200 level electives in areas of interest should be taken to get breadth in the discipline. Higher-level electives, which explore themes in more depth, should be taken in the third and fourth years. Of the core courses at the 300 level—students are required to take the Research Methods Core Course (ANTH 320 or SOC 320) in their third year and their Theory Core Course (ANTH 310 or SOC 310) in their third or fourth year. Senior Projects take place over the two semesters in the fourth year. Students who wish to pursue one may apply to do so at the end of their third year.

The Political Science Programme

Graduation Requirement: 130 Credit Hours

University Core: 8 Credit Hours

Kindly refer to *Section 1: Undergraduate Programme Policies and Regulation (Policy 3.2)*

Major Requirements: 52 credit hours (13 Courses)

A student doing a major in Political Science is expected to complete 13 courses in the discipline. Students can achieve this objective through a combination of core and elective courses. The 52 credit hours is spread out as follows:

Major Core Courses: 12 Credit Hours (3 Courses)

Political Science – Table 1

Code	Course Title	Credits
POL 100	Introduction to Political Science	4
POL 203	Introduction to Western Political Philosophy	4
POL 221	Introduction to Comparative Politics	4

Major Elective Courses: 40 Credit Hours (10 Courses)

In addition to the compulsory courses, students will need to take 10 courses from the list of electives in any of the following sub-fields of the discipline. They are required to take no more than one course at the 100 level and at least 3 courses at 300 or 400 levels.

1. Political Theory
2. Comparative Politics
3. International Relations
4. Political Sociology and Political Anthropology
5. Political Economy

Please note that this is not an exhaustive list. New courses will be added.

Political Science majors will also have the **option** of completing a Senior Project which is equivalent to two courses (8 credit hours). Students may not take a Senior Project to fulfil the 300/400 level elective requirement.

Political Science – Table 2

Code	Course Title	Credits
Political Theory and Methods		
POL 228	Introduction to Quantitative research method	4
POL 302	Islamic Political Philosophy	4
POL 3212	Contemporary Politics	4
POL 305	Contemporary Debates in Political Philosophy	4

POL 348	The Discontent of Politics	4
POL 442	Governance and its discontent	4
POL 439	Political Systems	4
Comparative Politics		
POL 239	Introduction to Government and Politics of China	4
POL 212	Class Structure in Pakistan	4
POL 220	American Government and Politics	4
POL 321	Comparative Constitutional Law and Politics	4
POL 322	Politics of India	4
POL 3012	Nations and Nationalism: From Theory to Practice	4
POL 324	Marxism and the Modern World	4
POL 328	Politics of Pakistan	4
POL 329	Introduction to African Politics	4
POL 3119	Political Parties	4
POL 3112	Contention and Rupture	4
POL 363	Populism	4
POL 3118	Politics of Culture	4
POL 413	Media and Politics	4
POL 414	Constitutionalism in Pakistan	4
POL 4112	Political Leadership	4
POL 423	Civil Society and Social Movements	4
POL 429	Theories of Civil Military Relations	4
International Relations		
POL 131	Introduction to International Relations	4
POL 230	Theories of International Relations	4
POL 232	The Politics of International Terrorism	4
POL 330	International Politics of South Asia	4
POL 331	Pakistan's Foreign Relations	4
POL 433	Critical Issues in Pakistan's Foreign Policy	4
POL 435	Globalization: Theory and Practice	4
Political Economy		
POL 242	Introduction to Development Studies	4
POL 209	Introduction to Political Economy	4
POL 243	Political Economy of Development	4
POL 341	Political Economy of Pakistan	4
POL 342	IPE: States and Markets	4
POL 4212	Agrarian Change and Peasant Struggle in the Twenty-First Century	4
Political Sociology And Political Anthropology		
POL 263	Political Sociology	4
POL 462	Anthropology of Globalization	4
POL 463	Anthropology of State	4

In addition to these electives, courses in other streams may also qualify as credit courses for Political Science majors.

Political Science Four Year Sample Programme

As a rule of thumb, students should look to spend their first year taking 100 level courses that introduce them to the broad themes of a discipline. These will include courses such as Introduction to Anthropology, Introduction to Philosophy, Introduction to Political Science, Introduction to Historical Studies, Introduction to Sociology, Introduction to Logic, Human Behaviour etc. These introductory courses must be taken in the first four semesters, so that students can make an informed decision on which major to pursue. Students should also take Writing & Communication in their first year, as solid writing skills will impact many subsequent courses that have a writing component to them. From the second year, 200 level electives in areas of interest should be taken to give breadth in the discipline. Higher - level electives, which explore themes in more depth, should be taken in the third and fourth years. Senior Projects take place over the two semesters in the fourth year. Students who wish to pursue one may apply to do so at the end of their third year

Guidelines for Senior Project in Political Science

Application and General Rules for Students

1. Students are required to have a minimum SGPA of 3.0 in order to do the Senior Project. Under exceptional circumstances, supervisors have the discretion to waive this requirement.
2. Students should have successfully completed the Qualitative Research Methods or where appropriate, Quantitative Analysis course before they start their senior project. All those students who have taken ECON 330 \econometrics do not need to take POL 228 or ANTH 320 for the SPROJ enrollment.
3. The application process for the senior project requires the submission of a ONE-page proposal to a potential faculty supervisor prior to the last day of teaching in the Spring semester before enrollment in the Senior Project. The proposal needs to outline a tentative title, aims and objectives, potential research question and methodology. Supervisor will then decide whether to accept the project.
4. Two students may be allowed to do a joint project but they have to justify the need of a partner in terms of the project workload and this need to be demonstrated in the proposal. Only the instructor will allow the students to make group where they seem that projects of two students overlap with one another.
5. Students have to enroll for the senior project in the Fall and Spring semester. Students are expected to work on their projects over the summer, but this CANNOT be a substitute for the Fall or Spring semester.

Grading

1. 20% of the grade is based on presentations and participation in the lunch seminars and colloquiums. Supervisors have the discretion to breakdown the remaining 80% as they see fit. However, students who miss seminars and/or colloquiums are penalized 10% of their grade for each absence.
2. The final paper component of the grade will be an average of the supervisor and second grader's grade.
3. Students can select their second grader in consultation with their supervisor.

SPROJ TIMELINE 2020-2021

- Tentatively, July 31, 2020, Submit ONE -page proposal to potential faculty supervisor. If approved, enrollment in SPROJ
- Full proposal due by the end of Fall 2020.
- Two lunch seminars to be held in Fall 2020
- Colloquium to be held in Mid-April 2021
- May 1, 2021, draft paper to be submitted to supervisor
- Last day of classes in May, submit full paper
- Word limit 8,000-10,000 words and if two students are doing it is 10,000-12,000 words.

The History Programme

Graduation Requirement: 130 Credit Hours

University Core: 8 Credit Hours

Kindly refer to Section 1: Undergraduate Programme Policies and Regulation (Policy 3.2)

Major Requirements: 52 credit hours (13 Courses)

A student doing a major in History is expected to complete 13 courses in the discipline. Students can achieve this objective through a combination of core and elective courses. The 52 credit hours is spread out as follows:

Major Core Courses: 4 Credit Hours (1 Course)

History – Table 1

Code	Course Title	Credits
HIST 100	Introduction to Historical Studies	4
OR		
HIST 101	World Civilizations	4
OR		
HIST 102	Introduction to World History	4
OR		
HIST 124	The World Since 1453	4

Major Elective Courses: 48 Credit Hours (12 Courses)

In addition to the compulsory courses, students will need to take 12 courses from the list of electives in any of the following sub-fields of the discipline. Of these courses, no more than three should be at the 100-level and at least three should be at the 300 and 400 level.

History majors will also have the option of completing a Senior Project, which is equivalent to two courses (8 credit hours). Students may not take a Senior Project to fulfil the 300/400 level elective requirement.

History – Table 2

Core Courses		Credits
HIST 100	Introduction to Historical Studies	4
HIST 101	World Civilizations	4
HIST 102	Introduction to World History	4
Introductory Courses		
HIST 112	Introduction to Archaeology	4
HIST 122	East Asian History	4
HIST 124	The world since 1453	4
HIST 126	Europe from the Neolithic to the 1600s	4

HIST 127	A People's History of Pakistan	4
History of Art and Architecture		
HIST 211	Art of Ancient Cultures	4
HIST 215	Buddhist Art and Architecture in the Subcontinent	4
HIST 216	Islamic Art and Architecture: An Historical Introduction	4
HIST 312	Mughal Architecture Babur to Aurangzeb	4
HIST 314	19th Century Sikh Wall Paintings in the Punjab	4
South Asian History		
HIST 2213	Foundations of Modern South Asian History	4
HIST 3213	The Regional Histories of Pakistan	4
HIST 327	The Mughals and their World	4
HIST 3214	Violence and Conflict in the Post-Colonial State in South Asia	4
HIST 3215	Imperialism and its Discontents in South Asia	4
HIST 439	Gender, Sexuality, and South Asia	4
HIST 422	South Asian History in Transnational Perspective	4
Islamic History		
HIST 232	The Islamic World, 600-1500 CE	4
HIST 334	The Islamic Intellectual Tradition: Hadith, Law and Theology	4
HIST 235	Jihad: A Social, Political and Theological History	4
HIST 3212	Resistance, Reform and Revolution: Islamic Movements Since 1800	4
Global History		
HIST 238	Debating Revolutions	4
HIST 2311	Nature, Power and Modernity	4
HIST 2216	World War Two: An Introduction	4
HIST 2215	The History of Colonial Expansion 1492 to 1919	4
HIST 2211	Modern East Asian History	4
HIST 329	The Cold War	4
HIST 3212	Resistance, Reform and Revolution	4
HIST 3211	China in Revolution, 1911-2011	4
HIST 335	The Urban Experience	4
HIST 436	War, Society and Memory	4

In addition to these electives, courses in other streams may also qualify as credit courses for History majors.

History Four Year Sample Programme

As a rule of thumb, students should look to spend their first year taking 100 level courses that introduce them to the broad themes of a discipline. Students should aim to take courses which would help them to make an informed choice as to which major to take at the School. Consequently, students should choose introductory courses in Anthropology and Sociology, Economics, English, History or Politics. Students should also take Writing & Communication in their first year, as solid writing skills will impact many subsequent courses that have a writing component to them. From the second year and third years, electives in areas of interest can be taken to give breadth in the discipline. It is strongly suggested that students take 100 level courses in their first year, 100 and 200 level courses in their second year, 200 and 300 level courses in their third year, and 300 and 400 level courses in their final year. Students will also have the opportunity to apply to study for a Senior Year Research Project in their final year, if they so wish.

The English Programme

Graduation Requirement: 130 Credit Hours

University Core: 8 Credit Hours

Kindly refer to Section 1: Undergraduate Programme Policies and Regulations (Policy 3.2)

Major Requirements: 52 credit hours (13 Courses)

A student doing a major in English is expected to complete 13 courses in the discipline. Students can achieve this objective through a combination of core and elective courses. The 52 credit hours is spread out as follows:

Major Core Courses: 8 Credit Hours (2 Course)

English – Table 1

Code	Course Title	Credits
ENGL 1000	Introduction to Literature in English	4
OR		
ENGL 1111	The Word and the World	4
OR		
ENGL 3510	Literary Theory	4
OR		
ENGL 4572	Colonial Discourse and Postcolonial Theory	4

Major Elective Courses: 44 Credit Hours (11 Courses)

In addition to the **two compulsory courses**, English majors are required to complete eleven elective courses chosen from the list below. Of these eleven electives at least four should be at 300 or 400 level. Courses offered as electives can vary. The list presented here is not exhaustive and is enriched, as new faculty members join, or existing faculty develops new courses.

English majors will also have the **option** of completing a Senior Project which is equivalent to two courses (8 credit hours). Students may not take a Senior Project to fulfil the 300/400 level elective requirement.

English – Table 2

GATEWAY COURSES		CREDITS
ENGL 1111	The Word and the World	4
ENGL 1000	Introduction to Literature in English	4
ENGL 2912	Introduction to Film Studies	4
AMERICAN LITERATURE		
ENGL 3264	Articulations of Nation; 19th Century American Poetry	4
ENGL 2252	Major Voices in contemporary American Fiction	4
ENGL 3254	Whale of a Tale; 19th Century American Novel	4
ENGL 2152	Gangs, Wizards and Soldiers: Young Adult Literature through the Ages	4

ENGL 2151	The Anti Scooby Doo's: A Selective Survey of Detective Fiction	4
ENGL 2253	Age of Modernism: Early 20th Century American Fiction	4
BRITISH LITERATURE		
ENGL 2353	Early 20th Century British and Irish Fiction	4
ENGL 2354	The Victorian Novel: Charles Dickens to Thomas Hardy	4
ENGL 2364	The Romantic Imagination: British Romantic Poetry	4
ENGL 3131	Greek and Shakespearean Tragedy	4
ENGL 3336	William Shakespeare	4
THEORY		
ENGL 4572	Colonial Discourse and Postcolonial Theory	4
ENGL 4591	Translation Theory	4
MASTERWORKS IN TRANSLATION		
ENGL 2652	Magical Realism	4
ENGL 3654	19th Century European Fiction: Tolstoy and Dostoevsky	4
WORLD ANGLOPHONE LITERATURE		
ENGL 2712	Modern South Asian Literature	4
ENGL 2713	Literature of Conflict	4
ENGL 3111	Literature of the Muslim World	4
ENGL 2132	Words are all we have: Identity Predicament in the Theatre of Absurd	4
ENGL 3152	The City in Literature	4
ENGL 3191	Literary Adaptations and its Discontents	4
ENGL 3711	Imagining Lahore	4
ENGL 3611	I am an Arab: Social & Pol. Dimensions in Contemporary Arab Lit.	4
ENGL 2212	Their Eyes were Watching God: Afro-American Voices in Literature	4
ENGL 2131	Modern Drama	4
ENGL 3112	Women of the Global South	4
ENGL 2111	Thinking like a Mountain: Literature and the Environment	4
ENGL 3150	Contemporary Short Stories	4
ENGL 3151	End of Nature: Disaster and Geopolitics in Envi.Fiction	4
ENGL 3812	African Literature	4

English Four-Year Sample Plan

As a rule of thumb, students should look to spend their first year taking 100/200 level courses that introduce them to the broad themes of a discipline. These will include courses such as Introduction to Literature in English, Introduction to Anthropology, Economics, Introduction to Philosophy, Introduction to Political Science, Introduction to Historical Studies, Introduction to Sociology, Introduction to Logic, Human Behaviour etc. These introductory courses must be taken in the first four semesters, so that students can make an informed decision on which major to pursue. Students should also take Writing & Communication in their first year, as solid writing skills will impact many subsequent courses that have a writing component to them. From the second year, electives in areas of interest can be taken to give breadth in the discipline. The final year should be for Senior Projects and higher-level electives.

Minors in Humanities and Social Sciences

The Department of Humanities and Social Sciences offers minors in a range of disciplines:

1. Anthropology and Sociology
2. Comparative Literary and Cultural Studies
3. English
4. Gender and Sexuality Studies
5. History
6. Philosophy
7. Political Science
8. Psychology
9. Study of Religion

The minor in HSS disciplines should appeal to students pursuing other majors. Students who finds themselves gravitating to Political Science will acquire a deeper perspective on Law and its philosophical underpinnings, a more nuanced understanding of the political debates within the field as well as t he larger political context within which policies are formulated. The minor in the HSS disciplines, emphasizes on the acquisition of intrinsically and instrumentally useful knowledge, as well as the cultivation of critical, analytical, and communication skills. By electing to minor in HSS disciplines, students will emerge from LUMS as well-rounded individuals, endowed with a wide repertoire of transferable skills and a unique insight, which should stand them in good stead as they prepare to embark on their careers.

Rules for HSS Minors

1. Students intending to complete a minor in a particular area should successfully complete a minimum of 6 regular courses carrying 4 credits each (for a total of 24 credit hours) in that area.
2. Students intending to minor in a particular area in HSS are required to complete two (2) core courses and four electives in that area. Of the four electives, at least two should be at the 300 level or above.
3. Politics and Economics majors cannot minor in either Politics or Economics.

Structure of HSS Minors

The two core courses in each of the areas of Anthropology/Sociology, History, and English, Philosophy, Political Science, Study of Religion, and Contemporary Literary and Cultural Studies are listed below:

HSS Minors – Table 1

Anthropology/Sociology
1. ANTH - 100 Introduction to Cultural Anthropology
2. SOC - 100 Introduction to Sociology

HSS Minors – Table 2

History
Any two 100-level History courses

HSS Minors – Table 3

English
1. ENGL – 1000 Introduction to Literature in English
2. ENGL – 1111 The Word and the World

HSS Minors – Table 4

Political Science
1. POL 100 – Introduction to Political Science
2. POL 203 – Introduction to Western Political Philosophy

HSS Minors – Table 5

Psychology
1. PSY 100 – Human Behavior
2. PSY 220 – Abnormal Psychology OR PSY 201 – Cognition

HSS Minors – Table 6

Philosophy	
1. PHIL 100 Introduction to Philosophy OR PHIL 102 Philosophy Gym	
2. PHIL 130 Logic and Critical Reasoning	
In addition, meeting either of the two types of objectives given below for the Philosophy minor, the students' choice of the rest of the four courses are made in accordance with the following specifications.	
<p>Students whose aim is Type 1 may, in consultation with the stream coordinator, choose any four philosophy courses including at least two courses that are pitched at level 300 or higher.</p>	<ul style="list-style-type: none"> • Students whose aim is Type 2 may pick four courses from any of the following recommended course groups. They must ensure that at least two of their courses are at level 300 or higher. • Applied Ethics: Moral Philosophy/Ethics; Applied Ethics; Religion and Science; Philosophy and Economics; any other course with the coordinator's approval. • Ethical Theory: Moral Philosophy/Ethics; Metaethics; Philosophy of Language; Knowledge and Reality; Philosophy and Economics; any other course with the coordinator's approval • Logic and Language: Philosophy of Language; Philosophical Logic; Formal Logic; Analytic Philosophy; Philosophy of Wittgenstein; any other course with the coordinator's approval • Epistemology and Metaphysics: Philosophy of Language; Knowledge and Reality; History of Western Philosophy OR Plato and Aristotle;

	<p>Philosophy of Science/Philosophy of Social Science; Philosophy of Mind; any other course with the coordinator's approval.</p> <ul style="list-style-type: none"> · Political Philosophy: Western Political Philosophy; Moral Philosophy/Ethics; Applied Ethics; Metaethics; Political Economy; Democracy and Difference; any other course with the coordinator's approval.
--	---

HSS Minors – Table 7

Study of Religion
1. REL 210 – Text, Performance, & Religion
2. REL 212 – Religion after Modernity OR REL 211 – Theories and Methods in the study of Religion (Both these courses will be anti-requisite of each other)

HSS Minors – Table 8

Contemporary Literary and Cultural Studies (CLCS)
1. CLCS 1000 – Engaging with Texts and Contexts: Stories of Home and Displacement AND
2. CLCS 3000 – Methods in Comparative Literature OR CLCS 4211 – Research Seminar in Screen Studies OR CLCS 2310 – Fiction Writing Workshop I OR CLCS 3321 – Translation Studies Workshop

Comparative Literary and Cultural Studies (CLCS) Minor

The programme in Comparative Literary and Cultural Studies (CLCS) extends across disciplinary boundaries and methods, asking students to engage with a variety of aesthetic and discursive forms in an attempt to better understand the human condition. In particular, CLCS is interested in enabling students to recognize the structures of power and hegemony that have shaped postcolonial societies and cultures, and consequently to grapple with the productive possibilities—artistic and scholarly—that this recognition engenders. Drawing on methods that broadly lie in the domains of the anthropological, the aesthetic, the literary-historical, the creative, and even the technological, CLCS is an attempt to develop an ethical humanistic engagement with the contemporary world.

Given its comparative underpinnings, CLCS remains committed to offering a curriculum that reflects linguistic histories and diversities across aesthetic and social realms, the scope of inquiry extending from the literary and visual to the quotidian. That is to say, CLCS courses and areas of focus are attentive to the place and development of literary, visual and related aesthetic categories in regional languages such as Urdu and Persian, but at the same time do not disregard the European and colonial histories of modernity that so often inform the cultural contexts of postcolonial societies.

Students of CLCS will emerge with the skills to undertake deep linguistic engagement, as well as with a broad understanding of the processes and constructs that go into the making of national cultures. The programme seeks to train students to go into careers such as print and media journalism, film-making, cultural organization, local government and grassroots work, creative writing, and academia, but does not rule out career options in the corporate and financial world.

CLCS is taught by a faculty who come from disciplines such as linguistic anthropology, comparative literature, Persian and Urdu literatures, film/screen studies, South-Asian studies, and creative practices such as fiction-writing, translation, and film-making. In addition to this permanent faculty, CLCS, through the Gurmani Center, will recruit practitioners such as local journalists, writers, and photographers to spend a semester and offer courses in the programme. The current full-time faculty include Dr. Fatima Fayyaz (Persian language and literature) Dr. Zebunnisa Hamid (film/screen studies), Mr. Zahid Hussain (creative writing, Punjabi language and literature), Dr. Maryam Wasif Khan (comparative literature), Dr. Gwendolyn Kirk (film/screen studies, linguistic anthropology), Ms. Noor Habib (comparative literature, Persio-Urdu poetics), and Mr. Bilal Tanweer (creative writing, translation, and literary studies). Adjunct /Visiting faculty include: Dr. Nasir Abbas Nayyar (modern Urdu literature) and Dr. Zia-ul Hassan (Urdu literature)

Core Courses

CLCS 1000 Engaging with Texts and Contexts (team-taught)

AND

CLCS 3000 Methods in Comparative Literature, **or**

CLCS 2310 Fiction Writing Workshop – I, **or**

CLCS 4211 Research Seminar in Screen Studies, **or**

CLCS 3321 Translation Studies Workshop

Gender and Sexuality Studies (GSS) Minor

Saida Waheed Gender Initiative

The minor in Gender and Sexuality Studies (GSS) includes a combination of foundational courses and electives with an interdisciplinary academic programme focusing on gender and sexuality. The programme's core curriculum builds upon feminist scholarship, incorporating interdisciplinary agendas, intellectual debates, changing methodological practices, and major scholarly shifts that inform the field of gender studies. As a programme committed to critical thinking and social analysis, the GSS minor introduces students not only to the complex histories, cultures, political activities, and expressions of gender and sexuality, but it also raises questions about larger social and institutional formations. Informed by the insights of critical race feminism, feminist critiques of conventional domains of knowledge, and queer inquiries challenging traditional understandings and assumptions about sexuality, this minor is designed to move students beyond simple binary descriptions and contemporary, popularized accounts of gender. Instead, gender is analyzed in the full complexity of its construction over time and using a variety of disciplinary lenses. This interdisciplinary minor will provide opportunities students across the university to broaden their understandings of the changing role of gender and sexuality in Pakistan and globally.

Furthermore, given the cross-disciplinary nature of the cores and electives on offer, the GSS Minor will equip students with the tools to bring critical feminist perspectives across a number of disciplines. This skill-set will be invaluable with the increased focus on the inclusivity of growth, gender inequalities, and a renewed emphasis on the Sustainable Development Goals, particularly by international, non-governmental and government organizations.

Structure

A total of six courses (two core courses and four electives) are required to fulfil the requirements of the GSS minor.

a) Core Courses

The two compulsory core courses are designed to set a foundation for the GSS minor and will provide students with a solid grounding in core concepts, theoretical perspectives, modes of inquiry, and bodies of knowledge used and produced by the discipline.

1. Gender and Power
2. Feminist Theories

a) Elective Courses*

1. Gender and Development
2. Women of the Global South
3. Feminist Political Thought
4. Gender and the Household
5. A Brief History of Feminist Movement in Pakistan

*This is an evolving list and new courses will be added by the department.

Guidelines for Senior Project in HSS Minors (CLCS, GSS, PHIL, PSY or REL)

- These guidelines are specifically for SPROJ taken in the following minors:
 - i. Comparative Literary and Cultural Studies
 - ii. Gender and Sexuality Studies
 - iii. Philosophy
 - iv. Psychology
 - v. Study of Religion

- Senior Projects taken in the aforementioned areas will have minor specific codes rather than the generic SS codes

- Only students pursuing the minor can sign up for a Senior Project in GSS, REL, PSY, PHIL or CLCS. In order to demonstrate this, the student must have taken 4 courses in the minor by the end of their Junior year.

- In the event that a student is not minoring, the Senior Project course code will be in their major.

- Students are advised not to pursue a Senior Project in these minors without having taken 4 courses in the minor by their Junior Spring.

- The Senior Project does not count as part of the six courses required for the minor.

Department of Economics

Economics is often called the “science of choice.” The Economics major helps develop clear and rational problem-solving skills useful in business, government, corporate and non-government sectors. The major not only provides an understanding of economic institutions and how they impact segments of the economy, it also provides students with the skills to solve problems that confront organizations, governments and citizens. The major provides rigorous quantitative tools that allow students to understand the domestic and global economic environment and analyze its impact. The BSc. (Honours) Economics major is a quantitatively oriented programme that provides excellent preparation for graduate studies and careers in economics, business administration, non-government organizations, academia and the corporate sector.

The Department of Economics offers a four-year BSc (Honours) degree in three majors, namely, Economics, Politics and Economics (P&E), and Economics and Mathematics (Econ-Math). It also offers a Minor in Economics.

The Economics Programme

Graduation Requirement: 130 Credit Hours

University Core: 8 Credit Hours

Kindly refer to Section 1: Undergraduate Programme Policies and Regulation (Policy 3.2)

Major Requirements: 51 credit hours (13 Courses)

The Economics Major will require the completion of the 13 courses (51 Credits). The distribution of the courses is as follows:

Economics Core Courses: 27 credit hours (7 courses)

Economics – Table 1

Code	Course Title	Credits
MATH 101	Calculus I	3
ECON 111	Principles of Microeconomics	4
ECON 121	Principles of Macroeconomics	4
ECON 211	Intermediate Microeconomics	4
ECON 221	Intermediate Macroeconomics	4
ECON 230	Statistics and Data Analysis	4
ECON 330	Econometrics	4
	Total	27

Note: The course ECON 230 Statistics and Data Analysis is equivalent to Math 231 Statistics, only if Math 230 Probability has also been taken previously. ECON 230 Statistics and Data Analysis is equivalent to DISC 203 Probability and Statistics.

Economics Elective Courses: 24 credit hours (6 courses)

Students majoring in Economics are required to take any 24 credit hours (6 elective courses), such that **at least two courses are at the 400 level** (Senior requirement). Students may not use a Senior Project (SPROJ) or an Independent Study to fulfil this requirement. Economics SPROJ will not be counted towards Economics elective requirement of 51 credit hours.

Note: Transfer students or the students who go on an exchange programme and fall short of 1 or 2 credits in their economics core or elective courses are allowed to take 1 or 2 credit Independent Study to fulfil graduation requirements. Those falling short of 3 or 4 credit hours can take an Economics elective course in addition to their major requirements.

Specific Courses Required: ECON 100 is a remedial course offered for students with little Background in economic analysis. It is not a core course and will not count towards the 51 credit hours Economics major requirements. However, it is compulsory for students who are from Matric system or did not take A levels Economics.

Free Electives: Can be taken from any specialization to complete 130 credit hours. ECON 100 and all Econ DCW/SPROJ/Independent Study count towards free electives.

BSc (Honours) SPROJ: Students with the necessary preparation may opt to work on a 4-credit hour or 8-credit hour SPROJ. The SPROJ may span one or two regular semesters and will **NOT** count towards the 51 credit hours of Economics elective requirements. It will count towards free electives. The Economics department will provide details regarding its registration process.

Elective Courses for Economics Majors:

CODE	COURSE TITLE
ECON 213	Behavioural Economics
ECON 233	Introduction to Game Theory
ECON 240	Development Economics
ECON 244	Introduction to Environmental Economics
ECON 245	Water Economics
ECON 261	Principles of Finance
ECON 262	Mathematical Applications in Economics
ECON 311	Industrial Organization
ECON 3110	Economics of Organizations and Management
ECON 314	Law and Economics
ECON 317	The Economics of Corruption
ECON 319	Agriculture, Price and Income policy
ECON 334	Time Series Econometrics
ECON 343	Agriculture and Food Policy
ECON 352	International Finance
ECON 363	Economics of Investment and Finance
ECON 3416	Regional Economics
ECON 371	Public Economics

ECON 372	Urban Economics
ECON 411	Advanced Microeconomics
ECON 414	Applied Microeconomics
ECON 417	Readings in the Political Economy of the Media
ECON 421	Advanced Macroeconomics
ECON 425	Applied Macroeconomics
ECON 441	Development Economic Theory
ECON 449	Philosophy and Economics
ECON 466	Financial Crises
ECON 468	Options Swaps and Futures
ECON 469	Advanced Corporate Finance
ECON 4410	Issues in Economic Policy
ECON 4413	Poverty and Income Distribution
ECON 4414	Topics in Energy Economics
ECON 4416	Advanced Urban Economics
ECON 3421	An Introduction to the Methods and Practice of Impact Evaluation

Courses offered as electives can vary. The list presented here is not exhaustive and is enriched, as new faculty members join, or existing faculty develops new courses.

The Politics and Economics (Joint Major) Programme

The Politics and Economics (P&E) Joint Major provides a strong base to those who intend to have knowledge of the political economy. The P&E programme is a carefully constructed major that provides students the opportunity to study two disciplines, as well as areas that cut across traditional departmental and disciplinary lines. Through courses developed and taught by Economics and Political Science faculty, students examine the globalizing world using a variety of conceptual lenses supplied by the social sciences, learn multiple ways of solving problems, and explore areas of inquiry that intersect traditional disciplines. The courses in Politics help students understand the dynamics of political systems, how they affect international relations and how they support a nation, thus realizing their responsibility to the society and the country. The study of Economics prepares students to take part in governmental policy making and changes in economic systems. Economic study not only impacts the individuals but also contribute to the society at large.

Graduation Requirement: 130 Credit Hours

University Core: 8 Credit Hours

Kindly refer to *Section 1: Undergraduate Programme Polices and Regulation (Policy 3.2)*

Economics Core Courses: 16 credit hours (4 courses)

Politics and Economics – Table 1

CODE	COURSE TITLE	CREDITS
ECON 111	Principles of Microeconomics	4
ECON 121	Principles of Macroeconomics	4
ECON 230	Statistics and Data Analysis	4
ECON 330	Econometrics	4
	Total	16

Note: ECON 230 Statistics and Data Analysis is equivalent to Math 231 Statistics, only if Math 230 Probability has also been taken previously. ECON 230 Statistics and Data Analysis is equivalent to DISC 203 Probability and Statistics.

Economics Elective Courses: 12 credit hours (3 courses)

Students majoring in Politics and Economics are required to take any 12 credit hours of Economics courses (3 courses), such that **at least one course is at the 400 level** (Senior requirement). Students may not use Economics core courses, Principles of Economics, Senior Project, or Independent Study to fulfil this requirement.

Note: Transfer students or the students who go on an exchange programme and fall short of 1 or 2 credits in their economics core or elective courses are allowed to take 1 or 2 credit Independent Study to fulfil graduation requirements. Those falling short of 3 or 4 credit hours can take an Economics elective course in addition to their major requirements.

Politics Core Courses: 12 credit hours (3 courses)

Politics and Economics – Table 2

CODE	COURSE TITLE	CREDITS
POL 100	Introduction to Political Science	4
POL 203	Introduction to Western Political Philosophy	4
POL 221	Introduction to Comparative Politics	4
	Total	12

In addition to the core courses, students majoring in Politics and Economics will need to take five elective courses in the discipline of Political Science. Of these, **at least two should be at 300 or 400 level**. A Senior Project in Political Science will count as a 100 or 200 level elective course. For a list of elective Political Science courses please refer to the course lists given under the Political Science Major.

Free Electives: Can be taken from any specialization to complete 130 credit hours. ECON 100 and all Econ DCW/SPROJ/Independent Study count towards free electives.

BSc (Honours) SPROJ: Students with the necessary preparation may opt to work on a 4-credit hour or 8-credit hour ECON SPROJ. The SPROJ may span one or two regular semesters and will NOT count towards the 51 credit hours of ECON requirements. It will count towards free electives.

A POL SPROJ spans two semesters and comprises 8 credit hours. A POL SPROJ will count as a 100 or 200 level POL elective. Students **may not** take a Senior Project to fulfil the 300/400 level POL elective requirement.

The Economics department will provide details regarding registration process for SPROJ.

The Economics and Mathematics (Joint Major) Programme

The Economics and Mathematics Joint Major provides a strong base to those students who intend to pursue further studies at the graduate level in the field of Economics. Students seeking admission to a graduate programme have a higher chance of getting admitted to top ranked schools if they have taken mathematics courses like calculus, real analysis, and linear algebra, during their undergraduate degree programme.

Entry Requirement for the Economics and Mathematics Joint Major:

A student wishing to major in Economics and Mathematics must have the following, at the time of applying for this major:

- 1) A CGPA of 3.3 or above.
- 2) A minimum of B in Calculus-I and Linear Algebra with Differential Equations.

The maximum number of students accepted into this major each year is 30.

Graduation Requirement: 130 Credit Hours

University Core: 8 Credit Hours

Kindly refer to *Section 1: Undergraduate Programme Policies and Regulation (Policy 3.2)*

Economics Core Courses: 28 credit hours (7 courses)

Economics and Mathematics – Table 1

CODE	COURSE TITLE	CREDITS
ECON 111	Principles of Microeconomics	4
ECON 121	Principles of Macroeconomics	4
ECON 211	Intermediate Microeconomics	4
ECON 221	Intermediate Macroeconomics	4
ECON 230	Statistics and Data Analysis	4
ECON 330	Econometrics	4
ECON 411	Advanced Microeconomics	4
Or		
ECON 421	Advanced Macroeconomics	4
	Total	28

Economics Elective Courses: 8 credit hours (2 courses)

Two or more courses with an ECON code are required beyond those listed as core Economics courses. Of these, **at least one must be at the 400 level** (Senior requirement). The Senior requirement cannot be fulfilled by the 400-level course taken as part of the core or by a Senior Project or Independent Study.

Note: Transfer students or the students who go on an exchange programme and fall short of 1 or 2 credits in their economics core or elective courses are allowed to take 1 or 2 credit Independent Study to fulfil graduation requirements. Those falling short of 3 or 4 credit hours can take an Economics elective course in addition to their major requirements

Suggested Economics Elective Courses

It is recommended that students in the Economics and Mathematics major who wish to go on to graduate programmes in economics, consider the following courses for their economics elective courses:

Economics and Mathematics – Table 2

CODE	COURSE TITLE	CREDITS
ECON 233	Introduction to Game Theory	4
ECON 411	Advanced Microeconomics	4
ECON 421	Advanced Macroeconomics	4
ECON 425	Applied Macroeconomics	4
ECON 414	Applied Microeconomics	4

ECON 100 is **mandatory** for students with no prior Economics background.

For a list of Economics elective courses please refer to the course list given under the Economics Major.

Note: ECON 411/421 may count as one elective **ONLY** if the student takes both courses. In such a case, one will count as a core course and the other as an elective. A single course **CANNOT** count both towards the core and elective requirement.

Mathematics Core Courses: 16 credit hours (5 courses)

Economics and Mathematics – Table 3

CODE	COURSE TITLE	CREDITS
MATH 101	Calculus-I	3
MATH 102	Calculus-II	3
MATH 120	Linear Algebra with Differential Equations	3
MATH 230	Probability	3
MATH 203	Introduction to Analysis-I	4

Mathematics Elective Courses: 6-8 credit hours (2 courses)

In addition to the core courses, students majoring in Economics and Mathematics will need to take 2 elective courses in the discipline of Mathematics. **Both courses should be at least 300 level.** For a list of elective Mathematics courses, please refer to the course lists given under the Mathematics Major.

Free Electives: Can be taken from any specialization to complete 130 credit hours. ECON 100 and all Econ DCW/SPROJ/Independent Study count towards free electives.

BSc (Honours) SPROJ: Students with the necessary preparation may opt to work on a 4-credit hour or 8-credit hour ECON SPROJ. The SPROJ may span one or two regular semesters and will NOT count towards the 51 credit hours of ECON requirements. It will count towards free electives. The Economics department will provide details regarding its registration process.

Economics Minor

1. Students intending to complete a minor in Economics should successfully complete a minimum of 6 regular courses carrying 4 credits each (for a total of 24 credit hours) in that area.
2. Students are required to complete three (3) core courses and three (3) electives in that area. The three electives could range from 200, 300 to 400 level courses dependent on whether a student has taken the required prerequisite for an elective. Out of three electives, **at least two electives should be at 300 level or higher**. Intermediate Microeconomics, Intermediate Macroeconomics or Statistic and Data Analysis could be taken as an elective, if not taken as a core. Economics electives exclude Principles of Economics, Senior Project, Independent Study and Directed Research Project.

Economics Core Courses	
1.	ECON 111 Principles of Microeconomics
2.	ECON 121 Principles of Macroeconomics
And any one of the following	
3.	ECON 211 Intermediate Microeconomics
4.	ECON 221 Intermediate Macroeconomics
5.	ECON 230 Statistics and Data Analysis

MGSHSS Major Declaration/Change And Inter-School Transfer Requirements

Major Allocation Requirements

- Completion of all first-year core buckets (Arts and Humanities, Social and Behavioral Sciences and STEM) AND Sophomore bucket (Contemporary Debates). No exception will be given to students starting FALL semester 2020.
- Completion of at least 44 Credit Hours.
- Completion of **at least one course** in the applied programme
- If students do not get their first or second preference, they will be emailed to send in their third preference.

Specific Economics Department requirements

- a. Economics and Mathematics (Joint Major)
 - i. At least B in MATH 101 & MATH 120 is required
 - ii. At least CGPA of 3.3
- b. Politics and Economics (Joint Major)
 - i. Applications will be sorted CGPA wise (priority given to CGPA and not preference)
 - ii. At least one course in Politics and Economics with a good grade⁷
- c. Economics
 - i. Applications to be sorted CGPA wise (priority given to CGPA and not preference)
 - ii. At least one course in Economics with a good grade⁸

Decision of enrollment in remedial course for Batch 2023 is pending. Department will decide when it is time for Batch 2023 to declare major.

Major Change Requirements

- Within HSS Department, major change will be allowed after Junior year (Case by case, departments can reject the application)
- Closed for Economics at the end of junior year (for example cannot move from Politics and Economics to Economics)
- Closed for inter-departments (From HSS to Economics) at the end of junior year. But open for Economics to HSS (case by case, departments can reject the application)
- There will be an assessment of whether students are able to complete the remaining requirements within the remaining time at LUMS (maximum 6 years)

Rejection of application if the student is unable to complete the major timely.

Rejection of application if the Programme Director feels they are not a good fit for the major.

Inter-school Requirements

- Completion of only first-year core buckets (Arts and Humanities, Social and Behavioral Sciences and STEM)
- Completion of at least 27 Credit hours (for inter-school end of first year)
- Completion of at least 44 Credit Hours (for inter-school end of sophomore year)

⁷ At least a B grade.

⁸ At least a B grade

- Completion of **at least one course** in the applied programme
- Good grades⁹ in courses taken in the applied programme
- Inter-school transfer is allowed at the end of first year and at the end of sophomore year

In case any application is rejected, a student in **first year** can re-apply in sophomore year. Sophomores rejected, may not be able to apply again.

First year students will eventually declare the same major in their sophomore year which they applied for in their first year. Submission of application to, for example Economics would not be permitted, if they applied for inter-school transfer to HSS.

Specific Economics Department Inter-school transfer requirements

- Closed in first year
- Open in sophomore year if there are any seats left.
- Priority given to CGPA and not preference

Academic Advising at MGSHSS

Academic advising aims to promote positive outcomes in MGSHSS students by supporting them through their journey at LUMS. It incorporates faculty, students and administrators who give both academic and non-academic guidance. MGSHSS advising works in tandem with the newly introduced online advising system to offer three layers of advising support. Staff academic advisors are always available to help students during enrollment periods and to respond to their academic needs. Faculty advisors offer two mandatory one-on-one meetings with the students each academic year. Apart from these mandatory meetings, students can set up appointments and discuss their academic progress, work planning charts and social adjustment issues. In addition, the Dean's office trains Peer Advising Leaders (PALs) for first year and sophomore classes. These PALs act as the first point of contact for students and work closely with the main advising staff in providing peer to peer advising. Academic advisors help students manage their degree pathways, course selection and combinations, connect with departments and resolve all academic issues.

The Faculty Advisor's Role and Responsibility In Undergraduate Academic Advising:

We are of the opinion that the faculty advisor acts as an understanding and knowledgeable guide to their advisees. Topics that can be discussed with advisees are:

1. Identify educational goals,
2. Connect academic choices to intellectual passions,
3. Time/stress management,
4. Studying strategies, reading strategies,
5. Academic integrity,
6. Development of skills and attitudes that will lead to success.

Advisor Details and Meetings:

The students are required to log on to their campus community, via Zambell account. They will find their advisor detail there. These lists are updated throughout the semester. There are 2 mandatory meetings

⁹ At least a B grade. In case grade is below, interview is necessary before finalizing a decision

throughout a year, one in each semester. However, for walk -ins and appointments, students must check online for the advisor available slots. It is considered best practice to contact/meet with the allocated advisor at least five times during a year.

For any kind of queries related to their academic management, enrollment, major selection/change issues, section change issues, and career counseling, students can drop an email at the school's official advising email address.

Website: <https://mgshssadvising.lums.edu.pk/>

Office Location: Dean's Wing MGS HSS. (main entrance side of MGS HSS Academic block, first floor)

Official Email: undergradadvising.mghss@lums.edu.pk

Contact Resources

<p>Dr. Ali Khan Dean, MGSHSS akhan@lums.edu.pk</p>	<p>Sophiya Anjum Dean's office, MGSHSS sophiya@lums.edu.pk</p> <p>Eilya Mohsin Dean's Office, MGSHSS eilya.mohsin@lums.edu.pk</p> <p>Hira Javied Dean's Office, MGSHSS hira.javied@lums.edu.pk</p>
<p>Dr. Hassan Karrar Head of Department, HSS hkarrar@lums.edu.pk</p>	
<p>Dr. Ali Hasanain Head of Department, Economics hasanain@lums.edu.pk</p>	<p>Mohammed Jamshaid Iqbal Economics jamshaid.iqbal@lums.edu.pk</p> <p>Maria Usman Economics maria.usman@lums.edu.pk</p>
<p>Dr. Sadaf Ahmad Programme Director, Anthropology and Sociology sadafah@lums.edu.pk</p>	<p>Mehreen Jamil Anthropology/Sociology, HSS mehreen.jamil@lums.edu.pk</p>
<p>Dr. Saba Pirzadeh Programme Director, English saba.pirzadeh@lums.edu.pk</p>	<p>Zofia Javed English, HSS zofia.javed@lums.edu.pk</p>
<p>Dr. Yunas Samad Programme Director, Political Science yunas.samad@lums.edu.pk</p>	<p>Salman Amin Political Science, HSS salman.amin@lums.edu.pk</p>
<p>Dr. Ali Usman Qasmi Programme Director, History ali.qasmi@lums.edu.pk</p>	<p>Zofia Javed History, HSS zofia.javed@lums.edu.pk</p>
<p>Dr. Shabbir Ahsen Programme Director, Philosophy sahsen@lums.edu.pk</p>	<p>Mehreen Jamil Philosophy, HSS mehreen.jamil@lums.edu.pk</p>
<p>Dr. Imran Rashid Programme Director, Psychology rashid@lums.edu.pk</p>	<p>Mehreen Jamil Psychology, HSS mehreen.jamil@lums.edu.pk</p>
<p>Dr. Nauman Faizi Programme Director, Study of Religion nauman.faizi@lums.edu.pk</p>	<p>Zofia Javed Study of Religion, HSS zofia.javed@lums.edu.pk</p>
<p>Ms. Rabia Nafees Shah Programme Director, Writing and Communication rabia.nafees@lums.edu.pk</p>	<p>Zofia Javed Writing and Communication, HSS zofia.javed@lums.edu.pk</p>

<p>Dr. Nauman Faizi Programme Director, Islamic Studies Nauman.faizi@lums.edu.pk</p>	<p>Zofia Javed Islamic Studies, HSS zofia.javed@lums.edu.pk</p>
<p>Dr. Shayan Rajani Programme Director, Pakistan Studies shayan.rajani@lums.edu.pk</p>	<p>Salman Amin Pakistan Studies, HSS salman.amin@lums.edu.pk</p>
<p>Mr. Bilal Tanweer Center Head, Gurmani Center for Languages and Literature Bilal.tanweer@lums.edu.pk</p>	<p>Aroosa Subhani Gurmani Center aroosa.subhani@lums.edu.pk</p>
<p>Dr. Maryam Wasif Khan Programme Director, Comparative Literary and Cultural Studies (CLCS) maryam.wasif@lums.edu.pk</p>	<p>Aroosa Subhani CLCS, Gurmani Center aroosa.subhani@lums.edu.pk</p>
<p>Dr. Gwendolyn Sarah Kirk Programme Director, Language gwendolyn.kirk@lums.edu.pk</p>	<p>Aroosa Subhani Language, Gurmani Center aroosa.subhani@lums.edu.pk</p>
<p>Dr. Nida Kirmani Programme Director, Gender and Sexuality Studies (GSS) nida.kirmani@lums.edu.pk</p>	<p>Aimen Majeedullah GSS, HSS aimen.majeedullah@lums.edu.pk</p>

SYED BABAR ALI SCHOOL OF SCIENCE AND ENGINEERING (SBASSE)

SBASSE offers a four-year BS degree in the following areas:

- Biology
- Chemistry
- Chemical Engineering
- Computer Science
- Economics & Mathematics
- Electrical Engineering
- Mathematics
- Physics

Graduation Requirements for SBASSE Majors:

REQUIREMENTS	CREDIT HOURS
Graduation Requirements	130-136
University Core	8 (3 courses)
University Distribution	9-12 (3 courses)
SBASSE Core	34
Major Requirements	50-76 (depending on the discipline)
Major Core required Courses	34-59
Major Electives	9-21
Free Electives	19-21 (6 for EE and CHE)

University Core and Distribution Requirements:

The University core requirements are of 8 credit hours, while the Out -Group Courses entail taking 3 courses outside the SBASSE.

University Core Courses:

Kindly refer to Section 1: Undergraduate Programme Policies and Regulation (Policy 3.2)

University Distribution Courses:

In-Group - The SBASSE core courses adequately meet the “four course requirements” outside your major, but within your group/area.

Out-Group - Kindly refer to Section 1: Undergraduate Programme Policies and Regulation (Policy 3.3)

SBASSE Core Courses:

The SBASSE core courses are of 34 credits which are divided into the following:

Biology	04 Credit hours
Chemistry	04 Credit hours
Computing	03 Credit hours
Electrical Engineering	01 Credit hours
Mathematics	09 Credit hours
Physics	10 Credit hours

SBASSE Elective*	03 Credit hours
Economics & Mathematics	08 Credit hours

***IMPORTANT:** The SBASSE Elective is an essential component of the SBASSE core curriculum. Students are required to enroll in any one 3 credit hour course offered by SBASSE in their Sophomore year or beyond. The SBASSE Elective must be outside a student’s major area of study but within SBASSE. It must be a 200+ level course.

For EE Majors PHY-204: Electricity and Magnetism will count towards their SBASSE Elective.

For CS and CHE Majors: (MATH 102) Calculus II will count towards their SBASSE Elective.

Major Core Requirements

For each SBASSE major these are:

Biology	48 Credit hours
Chemistry	47 Credit hours
Computer Science	42 Credit hours
Chemical Engineering	57 Credit hours
Economics & Mathematics	24/11 Credit hours
Electrical Engineering	59 Credit hours
Mathematics	34 Credit hours
Physics	40 Credit hours

Major Elective Requirements

Students pursuing different majors must enroll in elective courses offered by their department. The list of electives offered is fluid and can vary from one semester to another. Students may choose to follow a “stream” if offered by a particular department. Students must take a minimum of 9 credit hours from this category of courses; the maximum number of credit hours obtained from major elective courses varies depending on the discipline as follows:

Biology	09 Credit hours
Chemistry	09 Credit hours
Chemical Engineering	18 Credit hours
Computer Science	15 Credit hours
Economics & Mathematics	8/6-8 Credit hours
Electrical Engineering	17 Credit hours
Mathematics	21 Credit hours
Physics	18 Credit hours

Free Electives

In addition to the major core and major elective courses, students must enroll in courses categorized as “free electives”. The free electives may be “scattered” LUMS -wide or may be “concentrated” and used towards obtaining any one of the minor degrees offered by MGSHTS, SBASSE or SDSB. The total number of credit hours obtained from courses that are in the “free elective” category vary depending on the discipline as follows:

Biology	20 Credit hours
Chemistry	20 Credit hours
Chemical Engineering	06 Credit hours
Computer Science	19 Credit hours
Economics & Mathematics	25-30 Credit hours
Electrical Engineering	06 Credit hours
Mathematics	21 Credit hours
Physics	18 Credit hours

Structure of SBASSE Core

Credit hour distribution across SBASSE majors:

SBASSE – Table 1

Discipline	University Requirements (University Core+ Out-Group)	SBASSE Core Requirements	Major Requirements			
			Major Core	Major Elective	Free Elective	Total
Credit Hours						
Biology	20	34	48	9	20	131
Chemistry	20	34	47	9	20	130
Chemical Engineering	20	34	57	18	6	132-135*
Computer Science	20	34	42	15	19	130
Electrical Engineering	20	34	59	17	6	133-136*
Mathematics	20	34	34	21	21	130
Physics	20	34	40	18	18	130
Economics & Mathematics	20	34	35	16	25	130

* Depending upon University Distribution

First Year Courses

SBASSE – Table 2

FALL SEMESTER		CREDITS
MATH 101	Calculus I	3
PHY 101	Mechanics	4
CHEM 101	Principles of Chemistry	3
CS 100	Computational Problem Solving	3
EE 100	Engineering Laboratory	1
SS 101	Islamic Studies	2
PHY 100	Experimental Physics Lab 1	2
TOTAL		18

SPRING SEMESTER		
MATH 120	Linear Algebra with Differential Equation	3
PHY 104	Modern Physics	4
BIO 101	Introductory Biology	3
BIO 100	Biology Laboratory	1
CHEM 100	Experimental Chemistry	1
SS 100	Writing & Communication	4
TOTAL		16

Sophomore Year Courses

SBASSE – Table 3

SPRING SEMESTER		CREDITS
MATH 230	Probability	3
TOTAL		3
SSE XXX	SSE Elective (one 200+ course outside the major but within school)	3

Double Major Policy for SBASSE Students

After having declared a major, student may opt for a second major (space and fulfilment of other requirements permitting) no later than the start of sixth semester at LUMS, after due consultation with their faculty advisors. Completion of requirements of both majors does not automatically allow a student to claim a double major degree without declaring it beforehand in a timely manner.

Students need to fulfil the following requirements for a double major:

- Requirements of national and international accreditation bodies should be accounted for both majors in double major. Any course or credit-hours requirements and degree title should not contradict the official rules outlined by the respective accreditation body for that degree.
- For major(s) in SBASSE, the major selection requirements specified in the student handbook should be met.
- Successful completion of minimum 160 credit hours.
- Successful completion of SBASSE School Core requirements including courses and labs.
- A request for double major must be accepted by both the departments (majors).
- Students pursuing a double major need to complete the University core and University distribution requirements according to the primary declared major.
- The students are required to complete the core and elective requirements of both majors. This includes completion of major core and elective and school core and elective. In case of overlap in core and elective requirements (cross-listed courses) double counting is permitted.
- Minimum CGPA requirement for declaration of double major should be 3.00 and above. The students are required to maintain a minimum CGPA of 2.50 throughout the programme tenure.
- The maximum allowed time to complete the requirements of double major is six years from the year of admission at LUMS.
- Students wishing to pursue a double major need to fill the double major declaration form available at the Office of the Registrar portal: <http://portal.lums.edu.pk/RegistrarOffice>.

Department of Biology

Biology Core Courses

Biology department offers undergraduate programme in the following areas of specialization:

Molecular and Cellular Biology

Computational Biology

CODE	COURSE TITLE	CREDITS	PRE-REQUISITES
BIO 212	Biochemistry	3	BIO 101: Introductory Biology & CHEM 101: Principles of Chemistry
BIO 231	Computational Biology I	3	BIO 101: Introductory Biology & CS 100: Computational Problem Solving
BIO 216	Molecular Biology	3	BIO 101: Introductory Biology
BIO 221	Genetics	4	BIO 101: Introductory Biology
BIO 300	Methods in Molecular Biology	4/3	(BIO 212: Biochemistry & BIO 216: Molecular Biology) OR (BIO 216: Molecular Biology & BIO 221: Genetics) OR (BIO 212: Biochemistry & BIO 221: Genetics)
BIO 313	Cell Biology	3	BIO 216: Molecular Biology
BIO 314	Virology & Microbiology	3	BIO 216: Molecular Biology
BIO 331	Computational Biology II	3	(BIO 231: Computational Biology I) & (MATH 230: Probability)
BIO 401	Seminar in Biology – I	1	BIO 221: Genetics & BIO 212: Biochemistry & BIO 313: Cell Biology
BIO 402	Seminar in Biology- II	1	BIO 221: Genetics & BIO 212: Biochemistry & BIO 313: Cell Biology
BIO 415	Developmental Biology/	4/3	BIO 221: Genetics &

	Mechanisms of Development		BIO 313: Cell Biology
CHEM 311	Chemical Thermodynamics	3	CHEM 101: Principles of Chemistry & MATH101: Calculus I
CHEM 230	Organic Chemistry Lab I	2	CHEM 231: Fundamentals of Organic Chemistry
CHEM 231	Fundamentals of Organic Chemistry	3	CHEM 101: Principles of Chemistry
BIO 491	Senior Project-I	4	N/A
BIO 492	Senior Project-II	4	N/A
	TOTAL	48	

Biology Elective Courses

CODE	COURSE TITLE	CREDITS	PRE-REQUISITES
BIO 318	Neuroscience	3	BIO 313: Cell Biology
BIO 5311	Biostatistics	3	MATH 230: Probability
BIO 519	Immunology	3	BIO 216: Molecular Biology
BIO 521	Epigenetics/ Gene Regulation and Epigenetics	3	BIO 216: Molecular Biology & BIO 221: Genetics
BIO 532	Network Biology/ Biological Networks	3	BIO 101: Introductory Biology & CS 100: Computational Problem Solving & (MATH 230 OR MATH 234: Probability OR Probability with Statistics)
BIO 513	Biophysical Methods/ Biophysical Techniques	4/3	BIO 212/ CHEM 251: Biochemistry
BIO 535	Computation Proteomics / Protein Informatics	3	CS100: Computational Problem Solving AND (BIO231: Computational Biology I OR BIO212: Biochemistry OR BIO216: Molecular Biology)
BIO 522	Cancer Biology	3	BIO 313: Cell Biology

BIO 534	Systems Biology	3	(BIO 216: Molecular Biology OR BIO 212: Biochemistry OR CHEM 251: Biochemistry) & MATH 120: Linear Algebra with Differential Equations
BIO 536	Computational Genomics	3	CS 100: Computational Problem Solving AND (BIO 216: Molecular Biology OR BIO 221: Genetics OR BIO 231: Computational Biology I OR CS 232: Computational Biology I) AND (MATH 120: Linear Algebra with Differential Equations OR MATH 220: Linear Algebra I
Any other 300+ level course offered by the Department			
TOTAL REQUIRED CREDITS		9	

Biology – Programme Structure

Graduation Requirement		131 Credit Hours	
University Core		8 Credit Hours (3 Courses)	
University Distribution	Out-Group	9-12 Credit Hours (3 Courses)	
SBASSE Cores		34 Credit Hours (13 Courses)	
Major Requirement	Major Cores	48 Credit Hours	The number of courses taken towards these requirements will vary according to the course credit hour which can be of 3 or 4 credits
	Major Electives	9 Credit Hours	
	Total	57 Credit Hours	
Free Electives*		20 Credit Hours	

Sample Four Year Plan

Course Title		Credits	Code	Course Title	Credits
First Year Fall			First Year Spring		
CHEM 101	<u>Principles of Chemistry</u>	<u>3</u>	<u>BIO 100</u>	<u>Biology Laboratory</u>	<u>1</u>
PHY 104	<u>Mechanics</u>	<u>4</u>	<u>BIO 101</u>	<u>Introductory Biology</u>	<u>3</u>
MATH 101	<u>Calculus I</u>	<u>3</u>	<u>CHEM 100</u>	<u>Experimental Chemistry</u>	<u>1</u>
CS 100	<u>Computational Problem Solving</u>	<u>3</u>	<u>PHY 104</u>	<u>Modern Physics</u>	<u>4</u>
PHY 100	<u>Experimental Physics Lab I</u>	<u>2</u>	<u>MATH 120</u>	<u>Linear Algebra with Differential Equations</u>	<u>3</u>
EE 100	<u>Engineering Laboratory</u>	<u>1</u>	<u>SS 100</u>	<u>Writing & Communication</u>	<u>4</u>
SS 101	<u>Islamic Studies</u>	<u>2</u>			
Total		18	Total		16
Sophomore Fall			Sophomore Spring		
BIO 216	<u>Molecular Biology</u>	<u>3</u>	BIO 212	<u>Biochemistry</u>	<u>3</u>
BIO 221	<u>Genetics</u>	<u>4</u>	BIO 231	<u>Computational Biology I</u>	<u>3</u>
CHEM 231	<u>Fundamentals of Organic Chemistry</u>	<u>3</u>	CHEM 230	<u>Organic Chemistry Lab I</u>	<u>2</u>
SS 102	<u>Pakistan Studies</u>	<u>2</u>	<u>MATH 230</u>	<u>Probability</u>	<u>3</u>
	University Distribution	3-4		<u>SBASSE Elective**</u>	<u>3</u>
				University Distribution	4
Total		15-16	Total		18
Junior Fall			Junior Spring		
BIO 300/500	<u>Methods in Molecular Biology Laboratory</u>	<u>4</u>	BIO 415/515	<u>Developmental Biology/Mechanisms of Development</u>	<u>4</u>
BIO 313	<u>Cell Biology</u>	<u>3</u>	BIO 314	<u>Virology and Microbiology</u>	<u>3</u>
BIO 331	<u>Computational Biology II</u>	<u>3</u>	CHEM 311	<u>Chemical Thermodynamics</u>	<u>3</u>
	University Distribution	3-4	<u>BIO XXX</u>	<u>Major Elective</u>	<u>3</u>
	<u>Free Elective</u>	<u>3-4</u>		<u>Free Elective</u>	<u>3-4</u>
Total		16-18	Total		16-17
Senior Fall			Senior Spring		
BIO 401	<u>Seminar Course</u>	<u>1</u>	BIO 402	<u>Seminar Course</u>	<u>1</u>
BIO 491A	<u>Senior Project A</u>	<u>4</u>	BIO 491B	<u>Senior Project B</u>	<u>4</u>
<u>BIO XXX</u>	<u>Major Elective</u>	<u>3</u>	<u>BIO XXX</u>	<u>Major Elective</u>	<u>3</u>
	<u>Free Elective</u>	<u>3-4</u>		<u>Free Elective</u>	<u>3-4</u>
	<u>Free Elective</u>	<u>3-4</u>		<u>Free Elective</u>	<u>3-4</u>
Total		14-16	Total		14-16

*Credit Hours taken towards free electives will vary according to the number of credit hours taken for the University Distribution (Out group).

**The SBASSE Elective requirement is one course of 3 credits to be taken outside the major, but within SBASSE, in Sophomore year or beyond.

<u>University Core</u>	University Distribution	<u>SBASSE Core</u>	Major Core	Major Elective	<i>Free Elective</i>
Underline	Regular	Bold and Underline	Bold	Bold and Italic	<i>Italic</i>

Department of Chemistry and Chemical Engineering

Chemistry Core Courses

CODE	COURSE TITLE	CREDITS	PRE-REQUISITES
CHEM 231	Fundamentals of Organic Chemistry	3	CHEM 101: Principles of Chemistry
CHEM 230	Organic Chemistry Lab I	2	CHEM 231: Fundamentals of Organic Chemistry
CHEM 233	Molecular Spectroscopy	3	CHEM 231: Fundamentals of Organic Chemistry
CHEM 251	Biochemistry	3	CHEM 101: Principles of Chemistry & BIO 101: Introductory Biology
CHEM 221	Molecular Symmetry I	3	CHEM 101: Principles of Chemistry
CHEM 313	Special Topics in Physical Chemistry	3	CHEM 101: Principles of Chemistry
CHEM 314	Quantum Chemistry	3	CHEM 101: Principles of Chemistry & MATH 101: Calculus I
CHEM 324	Inorganic Chemistry I	3	CHEM 101: Principles of Chemistry
CHEM 320	Inorganic Chemistry Lab	2	CHEM 324: Inorganic Chemistry I
CHEM 332	Chemistry of the Organic Functional Groups	3	CHEM 231: Fundamentals of Organic Chemistry
CHEM 311	Chemical Thermodynamics	3	CHEM 101: Principles of Chemistry & MATH 101: Calculus I
CHEM 334	Advanced Organic Chemistry	3	CHEM 332: Chemistry of the Organic Functional Groups
CHEM 342	Analytical Chemistry I	3	CHEM 101: Principles of Chemistry
CHEM 410	Physical Chemistry Lab	2	CHEM 311: Chemical Thermodynamics
CHEM 430	Organic Chemistry Lab II	2	CHEM 230: Organic Chemistry Lab I & CHEM 332: Chemistry of the Organic Functional Groups
CHEM 491	Senior Project I	3	N/A
CHEM 492	Senior Project II	3	N/A
	TOTAL	47	

Chemistry Elective Courses

CODE	COURSE TITLE	CREDITS	PRE-REQUISITES
CHEM 261	Functional Materials for Modern Devices	3	CHEM 101: Principles of Chemistry
BIO 216	Molecular Biology	3	BIO 101: Introductory Biology
CS 200	Introduction to Programming	4	Sophomore Standing
CS 202	Data Structures	3	CS 200: Introduction to Programming
MATH 210	Introduction to Differential Equation	3	MATH 101: Calculus I
PHY 212	Quantum Mechanics I	3	PHY 104: Modern Physics
CHEM 218	Environmental Chemistry	3	CHEM 101: Principles of Chemistry
PHY 204	Electricity and Magnetism	3	PHY101: Mechanics
CHEM 352	Introduction to Drug Discovery & Development	3	CHEM 101: Principles of Chemistry
BIO 313	Cell Biology	3	BIO 101: Introductory Biology & BIO 216: Molecular Biology
CHEM 315	Nanoscale Science & Colloidal Chemistry	3	CHEM 101: Principles of Chemistry
CHE 260	Principles of Chemical Engineering	3	CHEM 101: Principles of Chemistry
CHE 313	Material Science and Engineering	3	CHEM 101: Principles of Chemistry
CHE XXX	Chemical Engineering Thermodynamics	3	CHE 210 OR CHEM 311
CHEM 424	Organo-Transition Metal Chemistry And Catalysis	3	CHEM 221: Molecular Symmetry I
CHEM 522	Inorganic Materials Chemistry	3	CHEM 324: Inorganic Chemistry I
CHEM 523	Organo-Transition Metal Chemistry	3	CHEM 324: Inorganic Chemistry I
CHEM 515	Polymer Science and Technology	3	CHEM 101
CHEM 534	Retrosynthesis	3	CHEM 334: Advanced Organic Chemistry
CHEM 433	Nanomedicine	3	CHEM 101: Principles of Chemistry
MATH 102	Calculus II	3	MATH 101: Calculus I
CHEM 432	Bio-Organic Chemistry	3	CHEM 231: Fundamentals of Organic Chemistry
PHY 312	Quantum Mechanics II	3	PHY 212: Quantum Mechanics I
CHEM 497	Directed Research	1-2	
TOTAL REQUIRED CREDITS		9	

Chemistry – Programme Structure

Graduation Requirement		130 Credit Hours	
University Core		8 Credit Hours (3 Courses)	
University Distribution	Out-Group	9-12 Credit Hours (3 Courses)	
SBASSE Cores		34 Credit Hours (13 Courses)	
Major Requirement	Major Cores	47 Credit Hours	The number of courses taken towards these requirements will vary according to the course credit hour which can be of 3 or 4 credits.
	Major Electives	9 Credit Hours	
	Total	56 Credit Hours	
Free Electives*	20 Credit Hours		

Sample Four Year Plan

Code	Course Title	Credits	Code	Course Title	Credits
First Year Fall			First Year Spring		
<u>CHEM 101</u>	<u>Principles of Chemistry</u>	<u>3</u>	<u>BIO 100</u>	<u>Biology Laboratory</u>	<u>1</u>
<u>PHY 101</u>	<u>Mechanics</u>	<u>4</u>	<u>BIO 101</u>	<u>Introductory Biology</u>	<u>3</u>
<u>MATH 101</u>	<u>Calculus I</u>	<u>3</u>	<u>CHEM 100</u>	<u>Experimental Chemistry</u>	<u>1</u>
<u>CS 100</u>	<u>Computational Problem Solving</u>	<u>3</u>	<u>PHY 104</u>	<u>Modern Physics</u>	<u>4</u>
<u>EE 100</u>	<u>Engineering Laboratory</u>	<u>1</u>	<u>MATH 120</u>	<u>Linear Algebra with Differential Equations</u>	<u>3</u>
<u>PHY 100</u>	<u>Experimental Physics Lab I</u>	<u>2</u>	<u>SS 100</u>	<u>Writing & Communication</u>	<u>4</u>
<u>SS 101</u>	<u>Islamic Studies</u>	<u>2</u>			
Total		18	Total		16
Sophomore Fall			Sophomore Spring		
<u>CHEM 231</u>	<u>Fundamental of Organic Chemistry</u>	<u>3</u>	<u>CHEM 233</u>	<u>Molecular Spectroscopy</u>	<u>3</u>
<u>CHEM 221</u>	<u>Molecular Symmetry - I</u>	<u>3</u>	<u>CHEM 251</u>	<u>Biochemistry</u>	<u>3</u>
	<u>SBASSE Elective**</u>	<u>3</u>	<u>CHEM 230</u>	<u>Organic Chemistry Lab - I</u>	<u>2</u>
	University Distribution	3-4	<u>MATH 230</u>	<u>Probability</u>	<u>3</u>
<u>SS 102</u>	<u>Pakistan Studies</u>	<u>2</u>		University Distribution	3-4
				<i>Free Elective</i>	3
Total		14-15	Total		17-18
Junior Fall			Junior Spring		
<u>CHEM 314</u>	<u>Quantum Chemistry</u>	<u>3</u>	<u>CHEM 313</u>	<u>Special Topics in Physical Chemistry</u>	<u>3</u>
<u>CHEM 324</u>	<u>Inorganic Chemistry I</u>	<u>3</u>	<u>CHEM 320</u>	<u>Inorganic Chemistry Lab</u>	<u>2</u>
<u>CHEM 332</u>	<u>Chemistry of Organic Functional Groups</u>	<u>3</u>	<u>CHEM 311</u>	<u>Chemical Thermodynamics</u>	<u>3</u>
<u>CHEM 342</u>	<u>Analytical Chemistry I</u>	<u>3</u>	<u>CHEM 334</u>	<u>Advanced Organic Chemistry</u>	<u>3</u>
	University Distribution	3-4	<u>CHEM XXX</u>	<u>Major Elective</u>	<u>3</u>
				<i>Free Elective</i>	3-4
Total		15-16	Total		17-18
Senior Fall			Senior Spring		
<u>CHEM 430</u>	<u>Organic Chemistry Lab II</u>	<u>2</u>	<u>CHEM 491B</u>	<u>Senior Project B</u>	<u>3</u>
<u>CHEM 491A</u>	<u>Senior Project A</u>	<u>3</u>	<u>CHEM XXX</u>	<u>Major Elective</u>	<u>3</u>
<u>CHEM XXX</u>	<u>Major Elective</u>	<u>3</u>	<u>CHEM XXX</u>	<u>Major Elective</u>	<u>3</u>
<u>CHEM 410</u>	<u>Physical Chemistry Lab</u>	<u>2</u>		<i>Free Elective</i>	3-4
	<i>Free Elective</i>	3-4		<i>Free Elective</i>	3-4
Total		16-18	Total		14-16

*Credit Hours taken towards free electives will vary according to the number of credit hours taken for the University Distribution (Out group).

**The SBASSE Elective requirement is one course of 3 credits to be taken outside the major, but within SBASSE, in Sophomore year or beyond.

<u>University Core</u>	University Distribution	<u>SBASSE Core</u>	Major Core	<i>Major Elective</i>	<i>Free Elective</i>
Underline	Regular	Bold and Underline	Bold	Bold and Italic	<i>Italic</i>

Chemical Engineering Core Courses

CODE	COURSE TITLE	CREDITS	PRE-REQUISITES
PHY 204	Electricity and Magnetism	3	PHY101: Mechanics
CHE 210	Physical Chemistry	3	CHEM 101: Principles of Chemistry
CHE 260	Principles of Chemical Engineering	3	CHEM 101: Principles of Chemistry
CHEM 231	Fundamentals of Organic Chemistry	3	CHEM 101: Principles of Chemistry
CHE 240	Engineering Mathematics	3	N/A
CHE 200	Chemical Engineering Lab-I	2	CHEM 101: Principles of Chemistry
CHE 332	Chemistry of Organic Functional Groups	3	CHEM 231: Fundamentals of Organic Chemistry
CHE 340	Transport Phenomena – I	3	MATH 101 & Math 102: Calculus I & Calculus II
CHE 2XX	Chemical Engineering Thermodynamics	3	CHE 210: Physical Chemistry
CHE 3XX	Math Methods in Chemical Engineering II	3	MATH 101 & MATH 102: Calculus I & Calculus II
CHE 320	Separation Processes	3	CHE 260: Principles of Chemical Engineering
CHE 3XX	Transport Phenomena – II	3	CHE 3XX: Transport Phenomena – I
CHE 3XX	Chemical Kinetics and Reaction Engineering	3	CHE 2XX: Chemical Engineering Thermodynamics
CHE 3XX	Multiphase Processing	3	NA
CHE 3XX	Chemical Engineering Lab – II	2	CHE 3XX: Separation Processes
CHE 4XX	Chemical Process Control	3	CHE 240: Engineering Mathematics
CHE 4XX	Chemical Process Design – I	3	CHE 320: Separation Processes OR CHE 3XX: Chemical Kinetics and Reaction Engineering
CHE 4XX	Chemical Engineering Lab – III	2	CHE 3XX: Chemical Kinetics and Reaction Engineering
CHE 4XX	Senior Project	3	N/A
CHE 4XX	Chemical Process Design – II	3	CHE 4XX: Chemical Process Design – I
TOTAL		57	

Chemical Engineering Elective Courses

CODE	COURSE TITLE	CREDITS	PRE-REQUISITES
CHE 262	Particle Science and Engineering	3	CHE 260: Principles of Chemical Engineering
CHE 252	Chemical Process Technology	3	CHEM 101: Principles of Chemistry
CHE 3XX	Chemical Process Economics	3	N/A
CHE 3XX	Energy & Fuels	3	CHEM 101: Principles of Chemistry
CHE 313	Material Science and Engineering	3	CHEM 101: Principles of Chemistry
CHE 3XX	Polymer Science & Technology	3	CHEM 101: Principles of Chemistry
CHE 4XX	Soft Matter Mechanics	3	CHE 3XX Polymer Science & Technology
CHE 312	Fundamentals of Environmental Engineering	3	CHEM 101: Principles of Chemistry
CHE 3XX	Introduction to Modeling and Simulation	3	CHE 260 Principles of Chemical Engineering
CHE 3XX	Occupational Health and Safety	3	CHEM 101: Principles of Chemistry
CHE 4XX	Heat Transfer	3	CHE 340 Transport Phenomena – I or CHE 3XX Transport Phenomena – II
CHE 4XX	Process Optimization	3	CHE 240 Engineering Mathematics, CHE 3XX Numerical Methods for Engineering
CHE 3XX	Introduction to Petroleum Engineering	3	CHE 260 Principles of Chemical Engineering
CHE 3XX	Renewable Energy Resources	3	CHEM 101: Principles of Chemistry
CHE 4XX	Chemical Engineering Plant Design	3	CHE 2XX Chemical Engineering Thermodynamics and CHE 3XX Chemical Kinetics and Reaction Engineering and CHE 320 Separation Processes
CHE 4XX	Surface Analysis	3	CHE 313 Material Science and Engineering
CHE 4XX	Colloidal Science	3	CHE 262 Particle Science and Engineering
CHE 4XX	Air Pollution Control	3	CHE 312 Fundamentals of Environmental Engineering
CHE 4XX	Solid Waste Disposal	3	CHE 312 Fundamentals of Environmental Engineering
TOTAL REQUIRED CREDITS		18	

** This is not a complete list of elective courses; more courses can be added in the list as per requirement.

Chemical Engineering – Programme Structure

Graduation Requirement		132-135* Credit Hours	
University Core		8 Credit Hours (3 Courses)	
University Distribution	Out-Group	9-12 Credit Hours (3 Courses)	
SBASSE Cores		34 Credit Hours (13 Courses)	
Major Requirement	Major Cores	57 Credit Hours	The number of courses taken towards these requirements will vary according to the course credit hour which can be of 3 or 4 credits.
	Major	18 Credit Hours	
	Electives	75 Credit Hours	
Total			
Free Electives*		6 Credit Hours	

Sample Four Year Plan

Code	Course Title	Credits	Code	Course Title	Credits
First Year Fall			First Year Spring		
<u>CHEM 101</u>	<u>Principles of Chemistry</u>	<u>3</u>	<u>BIO 100</u>	<u>Biology Laboratory</u>	<u>1</u>
<u>PHY 101</u>	<u>Mechanics</u>	<u>4</u>	<u>BIO 101</u>	<u>Introductory Biology</u>	<u>3</u>
<u>MATH 101</u>	<u>Calculus I</u>	<u>3</u>	<u>CHEM 100</u>	<u>Experimental Chemistry</u>	<u>1</u>
<u>CS 100</u>	<u>Computational Problem Solving</u>	<u>3</u>	<u>PHY 104</u>	<u>Modern Physics</u>	<u>4</u>
<u>EE 100</u>	<u>Engineering Laboratory</u>	<u>1</u>	<u>MATH 120</u>	<u>Linear Algebra with Differential Equations</u>	<u>3</u>
<u>PHY 100</u>	<u>Experimental Physics Lab I</u>	<u>2</u>	<u>SS 100</u>	<u>Writing & Communication</u>	<u>4</u>
			<u>SS 101</u>	<u>Islamic Studies</u>	<u>2</u>
Total		16	Total		18
Sophomore Fall			Sophomore Spring		
CHEM 231	Fundamental of Organic Chemistry	3	CHE 2XX	Chemical Engineering Thermodynamics	3
PHY 204	Electricity and Magnetism	3	CHE 2XX	Major Elective – I	3
<u>MATH 102</u>	<u>SBASSE Elective** (Calculus II)</u>	<u>3</u>	<u>MATH 230</u>	<u>Probability</u>	<u>3</u>
CHE 260	Principles of Chemical Engineering	3	CHE 240	Engineering Mathematics	3
CHE 210	Physical Chemistry	3	CHE 200	Chemical Engineering Lab – I	2
<u>SS 102</u>	<u>Pakistan Studies</u>	<u>2</u>		University Distribution	3-4
Total		17	Total		17-18
Junior Fall			Junior Spring		
CHE 3XX	Transport Phenomena – I	3	CHE 3XX	Transport Phenomena – II	3
CHEM 332	Chemistry of Organic Functional Groups	3	CHE 3XX	Chemical Kinetics and Reaction Engineering	3
CHE 3XX	Numerical Methods for Engineering	3	CHE 3XX	Multiphase Processing	3
CHE 320	Separation Processes	3	CHE 2XX	Major Elective – III	3
CHE 3XX	Major Elective – II	3	CHE 3XX	Major Elective – IV	3
	Free Elective	3	CHE 3XX	Chemical Engineering Lab – II	2
Total		18	Total		17
Senior Fall			Senior Spring		
CHE 4XX	Chemical Process Control	3	CHE 4XX	Senior Project	3
CHE 4XX	Chemical Process Design – I	3	CHE 4XX	Chemical Process Design – II	3
CHE 4XX	Major Elective – V	3	CHE 4XX	Major Elective – VI	3
CHE 4XX	Chemical Engineering Lab – III	2		Free Elective	3
	University Distribution	3-4		University Distribution	3-4
Total		14-15	Total		15-16

*Credit Hours taken towards free electives will vary according to the number of credit hours taken for the University Distribution (O ut group).

**The SBASSE Elective requirement is one course of 3 credits to be taken outside the major, but within SBASSE, in Sopho more year or beyond.

<u>University Core</u>	University Distribution	<u>SBASSE Core</u>	Major Core	Major Elective	<i>Free Elective</i>
Underline	Regular	Bold and Underline	Bold	Bold and Italic	<i>Italic</i>

Department of Computer Science

Computer Science Core Courses

Computer Science – Table 1

CODE	COURSE TITLE	CREDITS	PRE-REQUISITES
CS 200	Introduction to Programming	4	CS 100
CS 202	Data Structures	3	CS 200
CS 210	Discrete Mathematics	4	MATH 101
CS 225	Fundamentals of Computer Systems	4	CS 100
CS 300	Advanced Programming	3	CS 200
CS 310	Algorithms	3	CS202 and (CS 210 OR MATH 252)
CS 331	Artificial Intelligence	3	CS 100
CS 340	Databases	3	CS 202
CS 360	Software Engineering	3	CS 200
CS 370	Operating Systems	3	CS 202
CS 382	Network-Centric Computing	3	CS 200
CS 491	Senior Project I	3	N/A
CS 492	Senior Project II	3	N/A
TOTAL REQUIRED CREDITS		42	

Computer Science Elective Courses

This is a sample of electives; students can take any elective offered by the Computer Science Department.

Computer Science – Table 2

CODE	COURSE TITLE	CREDITS	PRE-REQUISITES
CS 315	Theory of Automata	3	CS 210
CS 436	Computer Vision Fundamentals	3	CS 200 & MATH 120
CS 452	Computer Graphics	3	CS 200 & MATH 120
CS 471	Computer Networks: Principles & Practices	3	CS 200
CS 432	Introduction to Data Mining	3	CS 202
CS 473	Network Security	3	CS 382 or CS 471
CS 535	Machine Learning	3	MATH 230 & CS 200 & MATH 120
CS 585	Service Oriented Computing	3	CS 340
CS 501	Applied Probability	3	MATH 101
CS 437	Deep Learning	3	CS 200 & MATH120
CS 466	Human Computer Interaction	3	N/A
CS 5620	Information and Communication Technology for Development	3	CS 200
CS 582	Distributed Systems	3	CS 382 or CS 471
CS 510	Design & Analysis of Algorithms	3	CS 210 & CS 202
CS 532	Intelligent Computing	3	N/A

CS 570	Advanced Operating Systems	3	CS 370
CS 678	Topics in Internet Research	3	CS 382 or CS 471 or CS 4713
CS 334	Principles and Techniques of Data Science	3	CS 100 & MATH 120
CS 4713	Introduction to the Internet: Protocols and Architecture	3	CS 200
CS 6312	Privacy in the Digital Age	1	N/A
CS 5312	Big Data Analytics	3	CS 202 or CS 210 or CS 310
CS 5316	Natural Language Processing	3	CS 300 & MATH 230
CS 6712	Topics in Internet Measurement	3	CS 382 or CS 471
CS 677	Internet of things	3	CS 382 or CS 471
CS 4714	Introduction to the Internet of Things	3	CS 382 or CS 471
CS 682	Topics in Computer and Network Security	3	CS 473
CS 5615	Introduction to Programme Analysis	3	CS 300
CS 5616	Programming Languages	3	CS 300
CS 666	Topics in Interactive Computing	3	CS 466
TOTAL REQUIRED CREDITS		15	

Computer Science – Programme Structure

Graduation Requirement		130 Credit Hours	
University Core		8 Credit Hours (3 Courses)	
University Distribution	Out-Group	9-12 Credit Hours (3 Courses)	
SBASSE Cores		34 Credit Hours (13 Courses)	
Major Requirement	Major Cores	42 Credit Hours	The number of courses taken towards these requirements will vary according to the course credit hour which can be of 3 or 4 credits.
	Major	15 Credit Hours	
	Electives	57 Credit Hours	
Total			
Free Electives*		19 Credit Hours	

Sample Four Year Plan

Freshman Fall			Freshman Spring		
Code	Title	Credits	Code	Title	Credits
<u>CHEM 101</u>	<u>Principles of Chemistry</u>	<u>3</u>	<u>BIO 100</u>	<u>Biology Laboratory</u>	<u>1</u>
<u>PHY 101</u>	<u>Mechanics</u>	<u>4</u>	<u>BIO 101</u>	<u>Introductory Biology</u>	<u>3</u>
<u>MATH 101</u>	<u>Calculus I</u>	<u>3</u>	<u>CHEM 100</u>	<u>Experimental Chemistry</u>	<u>1</u>
<u>CS 100</u>	<u>Computational Problem Solving</u>	<u>3</u>	<u>PHY 104</u>	<u>Modern Physics</u>	<u>4</u>
<u>EE 100</u>	<u>Engineering Laboratory</u>	<u>1</u>	<u>MATH 120</u>	<u>Linear Algebra with Differential Equations</u>	<u>3</u>
<u>PHY 100</u>	<u>Experimental Physics Lab 1</u>	<u>2</u>			
<u>SS 101</u>	<u>Islamic Studies</u>	<u>2</u>	<u>SS 100</u>	<u>Writing and Communication</u>	<u>4</u>
Total		18	Total		16
Sophomore Fall			Sophomore Spring		
Code	Title	Credits	Code	Title	Credits
CS 200	Introduction to Programming	4	CS 202	Data Structures	3
CS 210	Discrete Mathematics	4	CS 300	Advanced Programming	3
CS 225	Fundamentals of Computer Systems	4	<u>MATH 230</u>	<u>Probability</u>	<u>3</u>
<u>SS102</u>	<u>Pakistan Studies</u>	<u>2</u>			
<u>MATH 102</u>	<u>Calculus II (SBASSE Elective)**</u>	<u>3</u>	<u>CS XXX</u>	<i>Major Elective (300+ Level)</i>	3
				<i>Free Elective</i>	3
Total		17	Total		15
Junior Fall			Junior Spring		
Code	Title	Credits	Code	Title	Credits
CS 370	Operating Systems	3	CS 360	Software Engineering	3
CS 310	Algorithms	3	CS 331	Artificial Intelligence	3
CS 340	Database	3	CS 382***	Network Centric Computing	3
CS XXX	<i>Major Elective (300+ level)</i>	3	CS XXX	<i>Major Elective (300+ level)</i>	3
	University Distribution	<u>3-4</u>		University Distribution	3-4
Total		15-16	Total		15-16
Senior Fall			Senior Spring		
Code	Title	Credits	Code	Title	Credits
CS 491A	Senior Project A	3	CS 491B	Senior Project B	3
CS XXX	<i>Major Elective</i>	3	CS XXX	<i>Major Elective</i>	3
	<i>Free Elective</i>	3		<i>Free Elective</i>	3-4
	University Distribution	3-4		<i>Free Elective</i>	3
	<i>Free Elective</i>	3		<i>Free Elective</i>	3
Total		15-16	Total		15-16

*Credit Hours taken towards free electives will vary according to the number of credit hours taken for the University Distribution (Out group).

**The SBASSE Elective requirement for CS majors is fulfilled by (MATH 120) Calculus II.

***CS 471 and CS 473 satisfy the requirement to take CS 382.

<u>University Core</u>	University Distribution	SBASSE Core	Major Core	<i>Major Elective</i>	<i>Free Elective</i>
Underline	Regular	Bold and Underline	Bold	<i>Bold and Italic</i>	<i>Italic</i>

Department of Electrical Engineering

Electrical Engineering Core Courses

CODE	COURSE TITLE	CREDITS	PRE-REQUISITES
EE 201	Introduction to Programming	4	Sophomore Standing
PHY 204	Electricity and Magnetism	3	PHY 101: Mechanics
EE 202	Data Structures	3	CS 200: Introduction to Programming
EE 220	Digital Logic Circuits	3	Nil
EE 220L	Digital Logic Circuits Lab	1	Nil
EE 240	Circuits I	3	Math 101: Calculus I
EE 241L	Introductory Circuits Lab	2	Nil
EE 242	Circuits II	3	EE 240: Circuits I
EE 203	Engineering Models	3	NA/Co-Req EE 201/ Anti-Req Math 210
EE 310	Signals and Systems	3	MATH 102: Calculus II
EE 324	Microcontroller and Interfacing	2	EE 220: Digital Logic Circuits
EE 324L	Microcontroller and Interfacing Lab	1	EE 220: Digital Logic Circuits
EE 330	Electromagnetic Fields and Waves	3	PHY 204: Electricity and Magnetism & Math 102: Calculus II
EE 340	Devices and Electronics	3	EE 240: Circuits I & EE 242: Circuits II
EE 340L	Devices and Electronics Lab	1	EE 240: Circuits I & EE 242: Circuits II
EE 352	Electromechanical Systems	3	EE 242: Circuits II
EE 352L	Electromechanical Systems lab	1	EE 242: Circuits II
EE 361	Feedback Control Systems	3	EE 310: Signals and Systems
EE 361L	Feedback Control Systems Lab	1	EE 310: Signals and Systems
EE 380	Communication Systems	3	EE 310: Signals and Systems
EE 380L	Communication Systems Lab	1	EE 310: Signals and Systems
EE 341	Microelectronic Design	3	EE 340: Devices & Electronics
EE 491	Senior Project I	3	Senior Standing
EE 492	Senior Project II	3	Senior Standing
TOTAL		59	

Electrical Engineering Elective Courses

CODE	COURSE TITLE	CREDITS	PRE-REQUISITES
COMMUNICATIONS, SIGNALS AND CONTROL			
EE 411	Digital Signal Processing	4	EE 310: Signals & Systems
EE 412	Principles of Digital Audio and Video	3	CS 200: Introduction to Programming & (Junior EE OR CS, Senior EE OR CS, Graduate EE OR CS)
EE 414	Deep Learning	3	CS200: Introduction to Programming and MATH 120: Linear Algebra with differential equations
EE 471	Computer Networks	4	CS 200: Introduction to Programming

EE 483	Network Security	3	EE471: Computer Networks OR CS382: Network Centric Computing
EE 511	Advanced Digital Signal Processing	3	EE 310: Signals & Systems
EE 512	Digital Image Processing	3	EE 310: Signal & Systems OR EE 412: Principles of Digital Audio and Video OR EE 411: Digital Signal Processing
EE 513	Computer Vision Fundamentals	3	CS200: Introduction to Programming and MATH 120: Linear Algebra with differential equations
EE 514	Machine Learning	3	MATH 230: Probability
EE 515	Applied Probability	3	MATH 101: Calculus 1
EE 5312	Radar System	3	EE 330/PHY 305: Electromagnetic Fields & Waves
EE 560	Linear System Theory	3	EE 380: Communication Systems
EE 561	Digital Control Systems	3	EE 361: Feedback Control Systems
EE 562	Robot Motion Planning	3	EE 361: Feedback Control Systems OR CS 310: Algorithms
EE 563	Convex Optimization	3	MATH 120: Linear Algebra with Differential Equations
EE 564	Stochastic Systems	3	MATH 230: Probability
EE 565	Mobile Robotics	3	EE361: Feedback Control Systems
EE 567	Multi-agent Systems	3	At least Junior Standing.
EE 569	Dynamic Programming and Reinforcement Learning	3	At least Junior Standing.
EE 570	Digital Communication Principles	3	EE 380: Communication Systems
EE 572	Wireless Communications	3	EE 380: Communication Systems
EE 573	Image and Video Coding	3	EE 310: Signal & Systems OR Graduate level Standing
EE 574	Discrete-time Modem Design for Wireless Communications	3	EE 380: Communication Systems
EE 578	Information Theory and Machine Learning	3	MATH 230 - Probability
EE 582	Error Correction Coding	3	EE380: Communication Systems
EE 583	Network Protocol and Performance	3	EE 515/CS 501: Applied Probability
EE 664	Robot Dynamics and Control	3	EE 361: Feedback Control Systems OR EE 562: Robot Motion Planning
ELECTRONICS AND EMBEDDED SYSTEMS			
EE 320	Computer Organization and Assembly Language	4	EE/CS 220: Digital Logic Circuits OR Any Programming Course
EE 421	Digital Systems Design	4	EE 320: Computer Organization and Assembly Language OR EE 324: Microcontroller and Interfacing
EE 520	Computer Architecture	3	EE 320: Computer Organization & Assembly Language OR EE 324:

			Microcontroller & Interfacing
EE 522	Embedded Systems	3	EE 320: Computer Organization & Assembly Language OR EE 324: Microcontroller & Interfacing
EE 523	VLSI Design	3	EE 340: Devices & Electronics
EE 527	Mixed Signal Design	3	EE310: Signals and Systems EE 341: Microelectronic Design
EE 529	Custom IC Design	3	EE 341: Microelectronic Design
DEVICES, OPTICS, AND ELECTROMAGNETICS			
EE 332	Introduction to Photonics	3	PHY 211: Waves & Optics OR EE 330/PHY 305: Electromagnetic Fields & Waves
EE 433	Laser Engineering	3	PHY 211: Waves & Optics OR EE 330/PHY 305: Electromagnetic Fields & Waves
EE 434	Principles of Optics	3	EE 330/PHY 305: Electromagnetic Fields & Waves
EE 442	Semiconductor Devices	3	EE 340: Devices & Electronics OR PHY 204: Electricity & Magnetism
EE 524	Nano-Electronic Devices	3	EE 340: Devices & Electronics OR PHY 204: Electricity & Magnetism
EE525	Photovoltaic Devices	3	EE 340: Devices & Electronics OR PHY 204: Electricity & Magnetism
EE 528	Semiconductor Device Fundamentals	3	EE 340 for EE undergraduate students; PHY 204 for PHY undergraduate students. Basic programming knowledge/experience in MATLAB
EE 530	Antenna Theory and Design	3	EE 330/PHY 305: Electromagnetic Fields & Waves
EE 531	Microwaves and RF Design	3	EE 330: Electromagnetic Fields and Waves
EE 532	Opto-Electronic Devices	3	EE 330/PHY 305: Electromagnetic Fields & Waves EE 340: Devices & Electronics OR PHY 204: Electricity & Magnetism
EE 533	Quantum Optics	3	PHY 212: Quantum Mechanics I
EE 538	Photonics Fundamentals	3	EE 330/PHY 305: Electromagnetic Fields & Waves
EE 5312	Radar System	3	EE 330/PHY 305: Electromagnetic Fields & Waves
ENERGY AND POWER SYSTEMS			
EE 353	Electrical Power Systems	3	EE 242: Circuits II
EE 452	Power Electronics	4	EE 340: Devices & Electronics
EE 453	Power System Protection and Stability	3	EE 353: Electrical Power Systems

EE556	Power System Planning	3	EE 353: Electrical Power Systems
EE 553	High Voltage Engineering	3	EE 353: Electrical Power Systems
EE 554	Electrical Drives	3	EE452: Power Electronics
EE 555	Renewable Energy Systems	3	EE 340: Devices & Electronics
EE557	Electricity Markets	3	None
TOTAL REQUIRED CREDITS		17	

This is a sample list of elective courses. Other courses being offered by the department may also satisfy the elective requirement

Electrical Engineering – Programme Structure

Graduation Requirement		133-136* Credit Hours	
University Core		8 Credit Hours (3 Courses)	
University Distribution	Out-Group	9-12 Credit Hours (3 Courses)	
SBASSE Cores		34 Credit Hours (13 Courses)	
Major Requirement	Major Cores	59 Credit Hours	The number of courses taken towards these requirements will vary according to the course credit hour which can be of 3 or 4 credits.
	Major Electives	17 Credit Hours	
	Total	76 Credit Hours	
Free Electives*		6 Credit Hours	

Sample Four Year Plan

Code	Course Title	Credits	Code	Course Title	Credits
First Year Fall			First Year Spring		
<u>CHEM 101</u>	<u>Principles of Chemistry</u>	<u>3</u>	<u>BIO 100</u>	<u>Biology Laboratory</u>	<u>1</u>
<u>PHY 101</u>	<u>Mechanics</u>	<u>4</u>	<u>BIO 101</u>	<u>Introductory Biology</u>	<u>3</u>
<u>MATH 101</u>	<u>Calculus I</u>	<u>3</u>	<u>CHEM 100</u>	<u>Experimental Chemistry</u>	<u>1</u>
<u>CS 100</u>	<u>Computational Problem Solving</u>	<u>3</u>	<u>PHY 104</u>	<u>Modern Physics</u>	<u>4</u>
<u>EE 100</u>	<u>Engineering Laboratory</u>	<u>1</u>	<u>MATH 120</u>	<u>Linear Algebra with Differential Equation</u>	<u>3</u>
<u>PHY 100</u>	<u>Experimental Physics Lab I</u>	<u>2</u>	<u>SS 100</u>	<u>Writing & Communication</u>	<u>4</u>
<u>SS 101</u>	<u>Islamic Studies</u>	<u>2</u>			
Total		18	Total		16
Sophomore Fall			Sophomore Spring		
<u>MATH 102</u>	<u>Calculus II</u>	<u>3</u>	EE 242	Circuits II	3
PHY 204	Electricity and Magnetism (SBASSE Elective) **	3	EE 220	Digital Logic Circuits	3
EE 201	Introduction to Programming	4	EE 220L	Digital Logic Circuits Lab	1
EE 240	Circuits I	3	EE 241L	Introductory Circuits Lab	2
EE 203	Engineering Models	3	EE 202	Data Structures	3
<u>SS 102</u>	<u>Pakistan Studies</u>	<u>2</u>	<u>MATH 230</u>	<u>Probability</u>	<u>3</u>
			EE 310	Signals and Systems	3
Total		18	Total		18
Junior Fall			Junior Spring		
EE 380	Communication Systems	3	EE 352	Electromechanical Systems	3
EE 380L	Communication Systems Lab	1	EE 352L	Electromechanical Systems Lab	1
EE 324	Microcontroller and Interfacing	2	EE 361	Feedback Control Systems	3
EE 324L	Microcontroller and Interfacing Lab	1	EE 361L	Feedback Control Systems Lab	1
EE 330	Electromagnetic Fields and Waves	3	EE 341	Microelectronic Design	3
EE 340	Devices and Electronics	3		<i>Major Elective</i>	3
EE 340L	Devices and Electronics Lab	1		<i>Free Elective</i>	3
	University Distribution	3-4			
Total		17-18	Total		17
Senior Fall			Senior Spring		
EE 491A	Senior Project A	3	EE 491B	Senior Project B	3
EE XXX	Major Elective	3	EE XXX	Major Elective	3
EE XXX	Major Elective	4	EE XXX	Major Elective	4
	University Distribution	3-4		University Distribution	3-4
	<i>Free Elective</i>	3			
Total		16-17	Total		13-14

*Credit Hours taken towards free electives will vary according to the number of credit hours taken for the University Distribution (Out group).

**The SBASSE Elective requirement for EE majors is fulfilled by MATH 102: Calculus II as mentioned previously.

<u>University Core</u>	University Distribution	<u>SBASSE Core</u>	Major Core	<i>Major Elective</i>	<i>Free Elective</i>
Underline	Regular	Bold and Underline	Bold	Bold and Italic	Italic

Department of Mathematics

Mathematics Core Courses

In addition to all MATH prefix courses listed in the SBASSE core, Math majors must take all of the courses in the following table:

CODE	TITLE	CREDITS	PRE-REQUISITES
MATH 102	Calculus II	3	MATH 101: Calculus I AND MATH 120: Linear Algebra with Differential Equations
MATH 222	Linear Algebra II	3	MATH 120: Linear Algebra with Differential Equations
MATH 210	Introduction to Differential Equation	3	MATH 120: Linear Algebra with Differential Equations
MATH 204	Introduction to Formal Mathematics	4	MATH 120: Linear Algebra with Differential Equations
MATH 205	Introduction to Analysis I	4	MATH 102: Calculus II
MATH 309	Introduction to Analysis II	3	MATH 205: Introduction to Analysis I
MATH 300	Complex Variables	4	MATH 205: Introduction to Analysis I
MATH 310	Ordinary Differential Equations	3	MATH 210: Introduction to Differential Equation & MATH 205: Introduction to Analysis I
MATH 3010	Advanced Calculus	3	MATH 205: Introduction to Analysis I & MATH 222: Linear Algebra II
MATH 320	Algebra I	4	MATH 204: Introduction to Formal Mathematics
TOTAL		34	

Mathematics Elective Requirements

A minimum of 21 credit hours of Math courses outside of those listed in the above-mentioned table (Mathematics Core Courses) must be taken by students in the Math Major.

Note: MATH 100: Pre-Calculus does not count towards Mathematics electives for Mathematics Major.

Mathematics – Programme Structure

Graduation Requirement		130 Credit Hours	
University Core		8 Credit Hours (3 Courses)	
University Distribution	Out-Group	9-12 Credit Hours (3 Courses)	
SBASSE Cores		34 Credit Hours (13 Courses)	
Major Requirement	Major Cores	34 Credit Hours	The number of courses taken towards these requirements will vary according to the course credit hour which can be of 3 or 4 credits.
	Major	21 Credit Hours	
	Electives	55 Credit Hours	
Total			
Free Electives*		21 Credit Hours	

Sample Four Year Plan

Code	Course Title	Credits	Code	Course Title	Credits
First Year Fall			First Year Spring		
<u>CHEM 101</u>	<u>Principles of Chemistry</u>	<u>3</u>	<u>BIO 100</u>	<u>Biology Laboratory</u>	<u>1</u>
<u>PHY 101</u>	<u>Mechanics</u>	<u>4</u>	<u>BIO 101</u>	<u>Introductory Biology</u>	<u>3</u>
<u>MATH 101</u>	<u>Calculus I</u>	<u>3</u>	<u>CHEM 100</u>	<u>Experimental Chemistry</u>	<u>1</u>
<u>CS 100</u>	<u>Computational Problem Solving</u>	<u>3</u>	<u>PHY 104</u>	<u>Modern Physics</u>	<u>4</u>
<u>EE 100</u>	<u>Engineering Laboratory</u>	<u>1</u>	<u>MATH 120</u>	<u>Linear Algebra with Differential Equations</u>	<u>3</u>
<u>PHY 100</u>	<u>Experimental Physics Laboratory I</u>	<u>2</u>			
<u>SS 101</u>	<u>Islamic Studies</u>	<u>2</u>	<u>SS 100</u>	<u>Writing & Communication</u>	<u>4</u>
Total		18	Total		16
Sophomore Fall			Sophomore Spring		
<u>MATH 210</u>	<u>Introduction to Differential Equations</u>	<u>3</u>	<u>MATH 230</u>	<u>Probability</u>	<u>3</u>
<u>MATH 204</u>	<u>Introduction to Formal Mathematics</u>	<u>4</u>	<u>MATH 222</u>	<u>Linear Algebra II</u>	<u>3</u>
<u>MATH 102</u>	<u>Calculus II</u>	<u>3</u>	<u>MATH 205</u>	<u>Introduction to Analysis I</u>	<u>4</u>
<u>SS 102</u>	<u>Pakistan Studies</u>	<u>2</u>		<i>Free Elective</i>	<u>3</u>
	<u>SBASSE Elective**</u>	<u>3</u>		University Distribution	3-4
Total		15	Total		16-17
Junior Fall			Junior Spring		
<u>MATH 309</u>	<u>Introduction to Analysis II</u>	<u>3</u>	<u>MATH 300</u>	<u>Complex Variables</u>	<u>4</u>
<u>MATH 320</u>	<u>Algebra I</u>	<u>4</u>	<u>MATH 3010</u>	<u>Advanced Calculus</u>	<u>3</u>
	<i>Free Elective</i>	<u>3</u>	<u>MATH 310</u>	<u>Ordinary Differential Equations</u>	<u>3</u>
	<i>Free Elective</i>	<u>3</u>	<u>MATH XXX</u>	<u>Major Elective</u>	<u>3-4</u>
<u>MATH XXX</u>	<u>Major Elective</u>	<u>3</u>		University Distribution	3-4
Total		16	Total		16-18
Senior Fall			Senior Spring		
<u>MATH XXX</u>	<u>Major Elective</u>	<u>3</u>	<u>MATH XXX</u>	<u>Major Elective</u>	<u>3-4</u>
<u>MATH XXX</u>	<u>Major Elective</u>	<u>3-4</u>	<u>MATH XXX</u>	<u>Major Elective</u>	<u>3-4</u>
	<i>Free Elective</i>	<u>3</u>	<u>MATH XXX</u>	<u>Major Elective</u>	<u>3-4</u>
	<i>Free Elective</i>	<u>3-4</u>		<i>Free Elective</i>	<u>3</u>
	<i>Free Elective</i>	<u>3-4</u>		University Distribution	3-4
Total		15-18	Total		15-19

*Credit Hours taken towards free electives will vary according to the number of credit hours taken for the University Distribution (Out group).

**The SBASSE Elective requirement for BS Math majors is one course of 3 credits to be taken outside the major, but within SBASSE, in Sophomore year or beyond. For BSc Math majors, however, this requirement can be satisfied by taking any free elective of 3 credits.

<u>University Core</u>	University Distribution	<u>SBASSE Core</u>	Major Core	<i>Major Elective</i>	<i>Free Elective</i>
Underline	Regular	Bold and Underline	Bold	Bold and Italic	Italic

The Economics and Mathematics (Joint Major) Programme

The Economics and Mathematics joint major provides a strong base to those students who intend to pursue further studies at the graduate level in the field of Economics. Students seeking admission to a graduate programme have a higher chance of getting admitted to top ranked schools if they have taken mathematics courses like calculus, analysis, and linear algebra during their undergraduate degree programme.

A joint major housed at both Schools.

The major will now also be housed at Syed Babar Ali School of Science and Engineering (SBASSE), in addition to the currently offered programme BSc Economics and Mathematics by Mushtaq Ahmed Gurmani School of Humanities and Social Sciences (MGSHSS). Students graduate with a BS or BSc (Hons) degree respectively. The major requirements, major cores and electives are identical across both schools; however, school requirements differ.

In particular, students pursuing a BSc (Hons) in Economics and Mathematics must complete the university core and distribution in addition to the major core, elective and free elective requirements, while those pursuing a BS in Economics and Mathematics from the SBASSE must additionally complete the SBASSE school core requirements. The SBASSE sophomore students can opt for a major change whereas students from the rest of the schools can apply for an inter school transfer.

For the award of specialization Medal at the time of graduation, students of both schools are in competition for the major in Economics & Mathematics (joint major) Gold Medal.

For further details, please refer to Policy 27.3 (Medals: Specialization – Major)

Entry Requirement for Economics and Mathematics Joint Major:

A student wishing to major in Economics and Mathematics must have the following at the time of applying for this major:

1. A CGPA of 3.3 or above.
2. A minimum of B in Calculus-I and Linear Algebra with Differential Equations.

The maximum number of students accepted into this major each year is 50 (inclusive of both schools).

Graduation Requirements: 130 credit hours

Kindly refer to the Undergraduate Programme Policies and Regulations (Policy 3.2)

University Core: 8 credit hours

Kindly refer to the Undergraduate Programme Policies and Regulations (Policy 3.3).

Students enrolled in the BS programme must complete the SSE Core (34 credit hours) and take 3 out-group courses as part of their University Distribution. In-group requirements are taken care of by the SSE Core. Kindly refer to the Undergraduate Programme Policies and Regulations (Policy 3.3).

Major Core Course

Economics Core Courses

The following courses form the economic core for the major.

CODE	COURSE TITLE	CREDITS
ECON 111	Principles of Microeconomics	4
ECON 121	Principles of Macroeconomics	4
ECON 211	Intermediate Microeconomics	4
ECON 221	Intermediate Macroeconomics	4
ECON 330	Econometrics	4
ECON 411	Advanced Microeconomics	4
OR		
ECON 421	Advanced Macroeconomics	4
	TOTAL	24

Mathematics Core Courses

The following math courses form the mathematics core of the major.

CODE	COURSE TITLE	CREDITS
MATH 101	Calculus-I	3
MATH 102	Calculus-II	3
MATH 120	Linear Algebra with Differential Equations	3
MATH 230	Probability	3
MATH 205	Introduction to Analysis-I	4

In addition to the above course, students in the SSE stream must take MATH 231 - Statistics in place of ECON 230- Statistics and Data Analysis.

The following table provides a guide to where courses will fall for students in different streams.

COURSE	MGSHSS STREAM	SSE STREAM
ECON 111 Principles of Microeconomics	Major Core	Major Core
ECON 121 Principles of Macroeconomics	Major Core	Major Core
ECON 211 Intermediate Microeconomics	Major Core	Major Core
ECON 221 Intermediate Macroeconomics	Major Core	Major Core
ECON 330 Econometrics	Major Core	Major Core
ECON 411 Advanced Microeconomics or ECON 421 Advanced Macroeconomics	Major Core	Major Core
MATH 101 Calculus I	Major Core	SSE Core
MATH 102 Calculus II	Major Core	Major Core
MATH 120 Linear Algebra with Differential Equations	Major Core	SSE Core

MATH 205 Introduction to Analysis I	Major Core	Major Core
MATH 230 Probability	Major Core	SSE Core
MATH 231 Statistics or ECON 230 Statistics and Data Analysis	Major Core – May take either course	Major Core – Must take MATH 231

Economics Elective Courses; 8 Credit hours (2 courses)

Two or more courses with an ECON code are required beyond those listed as core Economics courses. Of these, at least one must be at the 400 level (Senior requirement). The Senior requirement cannot be fulfilled by the 400-level course taken as part of the core or by a Senior Project or Independent Study.

Note: Transfer students or the students who go on an exchange programme and fall short by 1 or 2 credits in their economics core or elective courses are allowed to take 1 or 2 credit Independent Study to fulfil graduation requirements.

Suggested Economics Elective Courses:

It is recommended that students in the Economics and Mathematics major who wish to go on to graduate programmes in economics, consider the following courses for their economics elective courses:

CODE	COURSE TITLE	CREDITS
ECON 233	Introduction to Game Theory	4
ECON 435	Advanced Game Theory	4
ECON 411	Advanced Microeconomics	4
ECON 421	Advanced Macroeconomics	4
ECON 425	Applied Macroeconomics	4
ECON 423	Growth Theories	4
ECON 414	Applied Microeconomics	4

Note: ECON 411/421 may count as one elective ONLY if the student takes both courses. In such a case, one will count in the core and the other as an elective. A single course CANNOT count both towards the core and elective requirement.

Mathematics Elective Courses: 6-8 credit hours (2 courses)

In addition to the core courses, students majoring in Economics and Mathematics will need to take 2-3 elective courses in the discipline of Mathematics. Both of these courses should be at least 300 level. For a complete list of elective Mathematics courses please refer to the course lists given under the Mathematics Major.

Free Electives: Can be taken from any specialization to complete 130 credit hours.

The Economics and Mathematics (Joint Major) – Programme Structure

Graduation Requirement		130 Credit Hours
University Core		8 Credit Hours (3 Courses)
University Distribution	In-Group	12-16 Credit Hours (4 Courses)
	Out-Group	9-12 Credit Hours (3 Courses)
	Total	21-28 Credit Hours (7 Courses)
SBASSE Cores		34 Credit Hours
Major Requirement	Economics Cores	24 Credit Hours (6 Courses)
	Economics Electives	8 Credit Hours (2 Courses)
	Mathematics Cores	11 Credit Hours (5 Courses)
	Mathematics Electives	6-8 Credit Hours (2-3 Courses)
	Total	49-51 Credit Hours (16-17 Courses)
Free Electives*	Courses can be taken from any area to complete 130 Credit Hours	

Sample Four Year Plan

Code	Course Title	Credits	Code	Course Title	Credits
First Year Fall			First Year Spring		
<u>MATH 101</u>	<u>Calculus-I</u>	<u>3</u>	<u>SS 101 / SS 102</u>	<u>Islamic Studies/ Pakistan Studies</u>	<u>4</u>
<u>CHEM 101</u>	<u>Principles of Chemistry</u>	<u>3</u>	<u>MATH 120</u>	<u>Linear Algebra with Differential Equations</u>	<u>3</u>
<u>PHY 101</u>	<u>Mechanics</u>	<u>4</u>	<u>BIO 100</u>	<u>Experimental Biology Laboratory</u>	<u>1</u>
<u>CS 100</u>	<u>Computational Problem Solving</u>	<u>3</u>	<u>BIO 101</u>	<u>Introductory Biology</u>	<u>3</u>
<u>EE 100</u>	<u>Engineering Laboratory</u>	<u>1</u>	<u>CHEM 100</u>	<u>Experimental Chemistry Laboratory</u>	<u>1</u>
<u>SS 100</u>	<u>Writing & Communication</u>	<u>4</u>	<u>ECON 111</u>	<u>Principles of Microeconomics**</u>	<u>4</u>
Total		18	Total		16
Sophomore Fall			Sophomore Spring		
<u>PHY 100</u>	<u>Experimental Physics Laboratory</u>	<u>1</u>	<u>PHY 104</u>	<u>Modern Physics</u>	<u>4</u>
<u>ECON 121</u>	<u>Principles of Macroeconomics</u>	<u>4</u>	<u>MATH 230</u>	<u>Probability</u>	<u>3</u>
<u>ECON 211</u>	<u>Intermediate Microeconomics</u>	<u>4</u>	<u>ECON 221</u>	<u>Intermediate Macroeconomics</u>	<u>4</u>
<u>MATH 102</u>	<u>Calculus II</u>	<u>3</u>	<u>MATH 205</u>	<u>Introduction to Analysis I</u>	<u>4</u>
	<u>SSE Elective</u>	<u>3</u>	<u>ECON XXX</u>	<u>Economics Elective 200/300+ level</u>	<u>4</u>
Total		16	Total		19
Junior Fall			Junior Spring		
<u>MATH 231</u>	<u>Statistics</u>	<u>4</u>	<u>ECON 411 / Advanced Microeconomics / Advanced</u>		<u>4</u>
<u>ECON 330</u>	<u>Econometrics</u>	<u>4</u>	<u>ECON 421</u>	<u>Macroeconomics</u>	
<u>MATH XXX</u>	<u>Mathematics Elective 300/400 level</u>	<u>3/4</u>		<u>University Distribution</u>	<u>3/4</u>
	<u>University Distribution</u>	<u>3/4</u>		<u>Free Electives</u>	<u>3/4</u>
<u>SS 101 / SS 102</u>	<u>Islamic Studies/ Pakistan Studies</u>	<u>4</u>		<u>Free Electives</u>	<u>3/4</u>
Total		18-20	Total		16-20
Senior Fall			Senior Spring		
<u>ECON XXX</u>	<u>Economics Elective 400 level</u>	<u>4</u>		<u>Free Electives</u>	<u>3/4</u>
<u>MATH XXX</u>	<u>Mathematics Elective 300/400 level</u>	<u>4</u>		<u>Free Electives</u>	<u>3/4</u>
	<u>University Distribution</u>	<u>3/4</u>		<u>Free Electives</u>	<u>3/4</u>
	<u>Free Electives</u>	<u>3/4</u>		<u>Free Electives</u>	<u>3/4</u>
	<u>Free Electives</u>	<u>3/4</u>			
Total		17-20	Total		13-16

*The number of courses taken towards Free Elective requirements will vary according to the Course Credit Hour which can be of 3 or 4 Cr.

**Can be taken either in Fall or Spring semester.

<u>University Core</u>	<u>University Distribution</u>	<u>SBASSE Core</u>	<u>Major Core</u>	<u>Major Elective</u>	<u>Free Elective</u>
Underline	Regular	Bold and Underline	Bold	Bold and Italic	Italic

Department of Physics

Physics Core Courses

CODE	COURSE TITLE	CREDITS	PRE-REQUISITES
MATH 102	Calculus II	3	MATH 101: Calculus I
PHY 204	Electricity and Magnetism	3	PHY 101: Mechanics
PHY 212	Quantum Mechanics I	3	PHY 104: Modern Physics
PHY 223	Mathematical Methods in Physics and Engineering I	3	MATH 102: Calculus II & (MATH 120: Linear Algebra with Differential OR MATH 220: Linear Algebra I
PHY 300	Experimental Physics II	3	PHY 100 Experimental Physics Lab I
PHY 305*	Electromagnetic Fields and Waves	3	PHY 204: Electricity & Magnetism & MATH 102: Calculus II
PHY 301	Classical Mechanics	3	PHY 101: Mechanics
PHY 312	Quantum Mechanics II	3	PHY 212: Quantum Mechanics I
PHY 313	Statistical Mechanics	4	PHY 101: Mechanics & PHY 104: Modern Physics
PHY 332	Condensed Matter Physics	3	PHY 212: Quantum Mechanics I
PHY 404	Relativistic Electrodynamics	3	PHY 305 Electromagnetic Fields and Waves
PHY 491	Senior Project I	3	N/A
PHY 492	Senior Project II	3	N/A
	TOTAL	40	

*Cross listed with EE 330: Electromagnetic Fields and Waves

Physics Elective Courses

This is a non-exhaustive list of Physics elective courses that are typically offered by the department.

CODE	COURSE TITLE	CREDITS	PRE-REQUISITES
PHY 106	The Universe Around Us	3	N/A
PHY 107	The Physics of Planets - Our Current and Future Homes	3	N/A
PHY 307	Introduction to Quantum Computing	3	PHY 212: Quantum Mechanics I
PHY 306	Python for Computing and Visualization	3	N/A
PHY 310	Experimental Physics III	3	PHY 300: Experimental Physics II OR EE 241L: Introductory Circuits Lab OR EE 220: Digital Logic Circuits
PHY 314	Introduction to Quantum Engineering	3	PHY 212: Quantum Mechanics I

PHY 323	Mathematical Methods for Physics and Engineering II	3	PHY 223: Mathematical Methods in Physics and Engineering I
PHY 335	Molecular Symmetry I	3	CHEM 101: Principles of Chemistry
PHY 337	Molecular Spectroscopy	3	CHEM 101: Principles of Chemistry
PHY 404	Relativistic Electrodynamics	3	PHY 305: Electromagnetic Fields & Waves
PHY 405	Engineering Physics Project Lab	3	PHY 300: Experimental Physics Lab II OR 340L: Devices and Electronics Lab
PHY 411	Quantum Optics	3	PHY 212: Quantum Mechanics I
PHY 415	Introduction to Photonics	3	PHY 211: Waves & Optics OR EE 330/PHY 305: Electromagnetic Fields & Waves
PHY 416	Principles of Optics	3	PHY 305: Electromagnetic Field and Waves
PHY 422	Lie Groups and their Representation	3	PHY 223: Mathematical Methods in Physics and Engineering I
PHY 433	Laser Engineering	3	PHY 211: Waves & Optics OR EE 330/PHY 305: Electromagnetic Fields & Waves
PHY 434	Introduction to Nanoscience	3	PHY 104: Modern Physics
PHY 442	General Relativity	3	None
PHY 451	Nuclear and Particle Physics	3	PHY 212: Quantum Mechanics I
PHY 501	Electrodynamics	3	PHY 305 Electromagnetic Fields and Waves
PHY 505	Computational Physics	3	PHY 212: Quantum Mechanics I AND PHY 305: Electromagnetic Fields and Waves
PHY 512	Advanced Quantum Mechanics	3	PHY 212: Quantum Mechanics I
PHY 516	Optoelectronic Devices	3	PHY 204: Electricity and Magnetism OR EE 340: Devices and Electronics
PHY 518	Photonic Fundamentals	3	PHY 305: Electromagnetic Fields and Waves
PHY 519	Symmetry Methods, Conservation Laws and Exact Solutions for Differential Equations	4	MATH 210: Introduction to Differential Equation
PHY 5313	Atomic and Laser Physics	3	PHY 212: Quantum Mechanics I
PHY 532	Photovoltaic Devices	3	PHY 204 Electricity and Magnetism OR EE 340 Devices and Electronics
PHY 534	Nano-electronic Devices	3	PHY 204 Electricity and Magnetism OR EE 340 Devices and Electronics
PHY 537	Semiconductor Devices and Fundamentals	3	PHY 204 Electricity and Magnetism
PHY 538	Special Topics in Condensed Matter Physics	3	PHY 332 Condensed Matter Physics

PHY 539	Introduction to Quantum Field Theory	3	PHY 312 Quantum Mechanics II AND PHY 301 Classical Mechanics
PHY 612	Introduction to Quantum Information Science	3	PHY 212: Quantum Mechanics I
PHY 633	Magnetism: Theory and Experiment	3	PHY 332 Condensed Matter Physics and PHY 212 Quantum Mechanics I
PHY 644	Cosmology and Black Holes	3	None
PHY 712	Seminars in Physics	1	PHY 312: Quantum Mechanics II
TOTAL REQUIRED CREDITS		18	

Physics – Programme Structure

Graduation Requirement		130 Credit Hours	
University Core		8 Credit Hours (3 Courses)	
University Distribution	Out-Group	9-12 Credit Hours (3 Courses)	
SBASSE Cores		34 Credit Hours (13 Courses)	
Major Requirement	Major Cores	40 Credit Hours	The number of courses taken towards these requirements will vary according to the course credit hour which can be of 3 or 4 credits.
	Major	18 Credit Hours	
	Electives	58 Credit Hours	
Total			
Free Electives*		18 Credit Hours	

Sample Four Year Plan

Code	Course Title	Credits	Code	Course Title	Credits
First Year Fall			First Year Spring		
<u>CHEM 101</u>	<u>Principles of Chemistry</u>	<u>3</u>	<u>BIO 100</u>	<u>Biology Laboratory</u>	<u>1</u>
<u>PHY 101</u>	<u>Mechanics</u>	<u>4</u>	<u>BIO 101</u>	<u>Introductory Biology</u>	<u>3</u>
<u>MATH 101</u>	<u>Calculus I</u>	<u>3</u>	<u>CHEM 100</u>	<u>Experimental Chemistry</u>	<u>1</u>
<u>CS 100</u>	<u>Computational Problem Solving</u>	<u>3</u>	<u>PHY 104</u>	<u>Modern Physics</u>	<u>4</u>
<u>EE 100</u>	<u>Engineering Laboratory</u>	<u>1</u>	<u>MATH 120</u>	<u>Linear Algebra with Differential Equations</u>	<u>3</u>
<u>SS 101</u>	<u>Islamic Studies</u>	<u>2</u>	<u>SS 100</u>	<u>Writing & Communication</u>	<u>4</u>
<u>PHY 100</u>	<u>Experimental Physics Laboratory I</u>	<u>2</u>			
	Total	18		Total	16
Sophomore Fall			Sophomore Spring		
<u>PHY 204</u>	<u>Electricity and Magnetism</u>	<u>3</u>	<u>PHY 223</u>	<u>Mathematical Methods in Physics I</u>	<u>3</u>
<u>MATH 102</u>	<u>Calculus II</u>	<u>3</u>	<u>PHY 312</u>	<u>Quantum Mechanics II</u>	<u>3</u>
<u>PHY 212</u>	<u>Quantum Mechanics I</u>	<u>3</u>	<u>MATH 230</u>	<u>Probability</u>	<u>3</u>
<u>SS 102</u>	<u>Pakistan Studies</u>	<u>2</u>	<u>PHY 305</u>	<u>Electromagnetic Fields and Waves</u>	<u>3</u>
	<u>SBASSE Elective**</u>	<u>3</u>		University Distribution	3-4
	University Distribution	3-4			
	Total	17-18		Total	15-16
Junior Fall			Junior Spring		
<u>PHY 300</u>	<u>Experimental Physics lab II</u>	<u>3</u>	<u>PHY XXX</u>	<u>Major Elective</u>	<u>3</u>
<u>PHY 301</u>	<u>Classical Mechanics</u>	<u>3</u>	<u>PHY 332</u>	<u>Condensed Matter Physics</u>	<u>3</u>
<u>PHY 313</u>	<u>Statistical Mechanics</u>	<u>4</u>	<u>PHY XXX</u>	<u>Major Elective</u>	<u>3</u>
<u>PHY 404</u>	<u>Relativistic Electrodynamics</u>	<u>3</u>	<u>PHY XXX</u>	<u>Major Elective</u>	<u>3</u>
	University Distribution	3-4		<u>Free Elective</u>	3-4
	Total	16-17		Total	15-16
Senior Fall			Senior Spring		
<u>PHY 491A</u>	<u>Senior Year Project A</u>	<u>3</u>	<u>PHY 491B</u>	<u>Senior Year Project B</u>	<u>3</u>
<u>PHY XXX</u>	<u>Major Elective</u>	<u>3</u>	<u>PHY XXX</u>	<u>Major Elective</u>	<u>3</u>
<u>PHY XXX</u>	<u>Major Elective</u>	<u>3</u>		<u>Free Elective</u>	<u>3</u>
	<u>Free Elective</u>	<u>3</u>		<u>Free Elective</u>	3-4
	<u>Free Elective</u>	<u>3</u>		<u>Free Elective</u>	<u>4</u>
	Total	15		Total	16-17

*Credit Hours taken towards free electives will vary according to the number of credit hours taken for the University Distribution (Out group).

**The SBASSE Elective requirement is one course of 3 credits to be taken outside the major, but within SBASSE, in Sophomore year or beyond.

<u>University Core</u>	University Distribution	<u>SBASSE Core</u>	Major Core	<i>Major Elective</i>	<i>Free Elective</i>
Underline	Regular	Bold and Underline	Bold	Bold and Italic	Italic

SBASSE Minors

In the beginning of Fall 2012, the SBASSE introduced minors in Biology, Chemistry, Computer Science, Mathematics, and Physics. MGSHSS and SDSB students keen to diversify their undergraduate experience in the sciences or SBASSE students wanting to complement their major discipline with another closely related area are encouraged to take full advantage of this new initiative. The minor degree is intended to impart fundamental knowledge in a specific area but carries with it limited depth and breadth. To satisfy degree requirements for a minor, students must accumulate a minimum of 18 credit hours by taking 6 courses in their area of interest and secure a cumulative GPA of 2.75 in them. Please refer to Section 1: Undergraduate Programme Policies and Regulation (Policy 18.1)

All general rules and regulations announced at University level in this Undergraduate Student Handbook must be adhered by students who are interested in obtaining a minor in SBASSE. Courses which are part of major core in an area will not count towards their minor; students must therefore take additional courses in an area, prescribed by a department to fulfil their minor degree requirements.

SBASSE departments offering a minor have provided a menu of compulsory courses, from which a certain number must be taken, in order to qualify for the minor degree. SBASSE students choosing any of the compulsory courses as “SBASSE elective” must take another course from the list, since one course cannot be used simultaneously towards a minor as well as to satisfy SBASSE elective requirement. Additionally, students must take two 300 level courses from the list of elective courses provided by each discipline.

List of courses that can be taken to obtain a minor in each of the five areas at SBASSE is given.

Biology Minor

To obtain a minor in Biology, students must take a minimum 18 credits of courses. Students should note that the SBASSE elective will not double count towards both Biology minor and the SBASSE elective requirement.

Compulsory Courses

From the list of compulsory courses, a student must take at least two courses in addition to BIO 101 and BIO 216 (both deemed as minor “core” courses). SBASSE students choosing any of the compulsory courses as SBASSE elective must take an additional course from the list of compulsory courses. Students should note that the SBASSE elective will not double count towards both Biology minor and SBASSE elective.

BIO 101: Introductory Biology	3 credit hours
BIO 212: Biochemistry*	3 credit hours
BIO 216: Molecular Biology	3 credit hours
BIO 221: Genetics	4 credit hours
BIO 231: Computational Biology I	3 credit hours

*Biochemistry (BIO 212) will not count towards the minor requirements for students majoring in Chemistry, who take it as part of Chemistry major core.

Optional Courses

Students may take any of the Biology courses, except BIO 100 and BIO 300/ 500 to complete 18 credit hours. However, Biology Courses listed as major requirements of a specific discipline will not double count towards the minor in Biology:

- BIO 313: Cell Biology
- BIO 314: Virology and Microbiology
- BIO 318: Neuroscience
- BIO 331: Computational Biology II
- BIO 415/515: Developmental Biology
- BIO 426/526: Human Genetics
- BIO 432/532: Network Biology
- BIO 521: Gene Regulation and Epigenetics

Chemistry Minor

To obtain a minor in Chemistry, students must take a minimum 18 credits of courses which is equivalent to six theory courses. As per general policy of minors, double counting of courses is not allowed (i.e., a course can satisfy the requirements of either a major or a minor, but not both). The same rule applies to the SBASSE elective and minor courses as well. Students intending to complete a minor should achieve a minimum cumulative GPA of 2.75 in chemistry courses.

Compulsory Courses

Of the following, Principles of Chemistry (CHEM 101) is a compulsory course and students are required to choose at least two courses from the remaining four. Note that, CHEM 231 would not count as a minor course for Biology major students as it is a part of their major core and they would be required to take two more courses from this list in addition to the compulsory course.

CHEM 101:	Principles of Chemistry	3 Credit Hours
CHEM 231:	Fundamentals of Organic Chemistry	3 Credit Hours
CHEM 324:	Inorganic Chemistry I	3 Credit Hours
CHEM 314:	Quantum Chemistry	3 Credit Hours
CHEM 233:	Molecular Spectroscopy	3 Credit Hours

Optional Courses

Students must take a minimum of three elective courses from the following list. Additional course(s) may be required for a minor in chemistry if students are also taking any of the courses as the SBASSE elective or as a part of their major core.

- CHEM 311: Chemical Thermodynamics
- CHEM 313: Special Topics in Physical Chemistry
- CHEM 221: Molecular Symmetry I
- CHEM 342: Analytical Chemistry I
- CHEM 332: Chemistry of the Organic Functional Groups
- CHEM 334: Advanced Organic Chemistry

Computer Science Minor

To obtain a minor in Computer Science, students must take a minimum of 18 credits of Computer Science courses. 10 Credit hours are of compulsory courses. The rest can be completed by taking three additional CS courses, at least two of which must be 300+ level.

Compulsory Courses

CS 100: Computational Problem Solving 3 Credit Hours

Or

CS 101: Introduction to Computing 3 Credit Hours

CS 200: Introduction to Programming 4 Credit Hours

CS 202: Data Structures 3 Credit Hours

Optional Courses

Three additional Computer Science Courses of at least 3 credit hours each are required to complete CS minor. At least two of these optional courses must be of 300 level or above.

Please note:

Seminar courses, Independent Studies, and Projects will not count towards this requirement.

Optional courses do not include 100 level CS courses

Mathematics Minor

To obtain a minor in Mathematics, students must take a minimum of 18 credit hours. Only one of the Mathematics courses in the SBASSE core will count towards minor requirements.

Compulsory Courses

At least one course must be taken out of the following:

MATH 205: Introduction to Analysis I 4 Credit Hours

MATH 320: Algebra I 4 Credit Hours

MATH 3010: Advance Calculus 3 Credit Hours

Beyond one course from the list of compulsory courses, at least 3 credit hours are to be taken from 300/400 level Mathematics courses.

Optional Courses

Students may take any of the Mathematics courses, except MATH 100, to complete 18 credit hours. However, Mathematics courses listed as major requirements of a specific discipline will not double count towards minor in Mathematics.

Physics Minor

The Physics minor requires students to take minimum 19 credits of courses in some combination of 3/4 credit hour courses. SBASSE students choosing any of the courses as the SBASSE elective must take an additional physics course of their choice at 200+ level, since the SBASSE elective will not be double counted as part of Physics minor.

Compulsory Courses

PHY101: Mechanics*	4 Credit Hours
PHY104: Modern Physics*	4 Credit Hours
PHY204: Electricity and Magnetism**	3 Credit Hours
PHY212: Quantum Mechanics I	3 Credit Hours

*SBASSE students can only count one of Mechanics and Modern Physics towards their minor requirements. SBASSE students (non-EE) would therefore have to take one additional Physics course at 200+ level to complete the minor credit hour requirements.

**Electricity and Magnetism will not count towards the minor requirements of EE major students who take it as part of EE major core. EE students would need to take two additional Physics courses at 200+ level to complete the minor credit hour requirements.

Optional Courses

Students must take any two 300+ level Physics courses.

Academic Advisement at SBASSE

Academic Advising is a process of helping students plan their academic career during their undergraduate degree programme. This advising can be about course planning and enrollment, major selection, maintaining good academic standing, extra-curricular activities, guidance of career or any other issues that require intensive counseling. Particularly in the first-year, students may have questions about how to manage their course load if they want to take a course from other school or what if they don't get an y section of a course etc. At Syed Babar Ali School of Science & Engineering (SBASSE), students are provided academic advising through a faculty adviser and staff advisers in the Dean's Academic Affairs Office.

Role of Faculty Advisors:

In their first year at SBASSE, students are assigned a specific faculty member as an Advisor. For first-year students, there is a minimum requirement of having two meetings per year, as mandatory criteria, though students can meet their respective advisor as much time as they wish. Once the students move to their sophomore year and have declared their major, they would then be reassigned an advisor in their major for the remainder of their programme at SBASSE. While meetings are no longer mandatory in junior or senior years, students are encouraged to meet with their advisers in order to make the most of their academic career at SBASSE. Students can access the information about their faculty advisor using Zambeel Self Service.

Role of Staff Advisers In The Dean's Academic Affairs Team:

Staff advisers are there to help student get through the process of enrollment smoothly. And after that they help them with any kind of academic/non-academic management issues they might face during entire 4 years of their degree at LUMS.

For any kind of queries related to your academic management, enrollment, major selection/change issues, section change issues, and career counseling, you can drop an email at the school's official advising email address.

Office Location: Dean's Wing, 4th Floor, SSE Building

Official Email: undergradadvising.sbasse@lums.edu.pk

SHAIKH AHMAD HASSAN SCHOOL OF LAW (SAHSOL)

The Shaikh Ahmad Hassan School of Law (SAHSOL) B.A.-LLB (Hons) is a five-year, full-time programme, consisting of a two-year B.A. phase followed by the LLB degree, accredited by the Pakistan Bar Council as a qualifying law degree. Combining a B.A and an LLB in one programme offers our students the best of both worlds: a solid grounding in the liberal arts followed by a thorough professional training in law.

The B.A. phase prepares students for the study of law, introducing them to a range of relevant subjects from a variety of disciplines, such as Economics, Political Science, Psychology, Anthropology/Sociology and Science, offered by the other four Schools of LUMS. Covering a wide range of topics and subject areas, available B.A. courses include Critical Thinking, Moral Philosophy, Principles of Financial Accounting, Introduction to Microeconomics, Politics of Education and Modern Physics. The three-year LLB phase consists of mandatory core law courses prescribed by the Pakistan Bar Council, such as Criminal, Contract and Constitutional Law. Students have ample opportunity to complement these core courses with a wide variety of elective law courses in whatever area of law they want to specialize in, such as Law and Practice of International Commercial Arbitration, Intellectual Property Law and Competition Law and Antitrust.

Classes are taught through a combination of lectures and seminar groups, and students are assessed by a mixture of graded instruments: examinations, quizzes, presentations and written assessments.

The School of Law prides itself on an interactive teaching environment and a historically low student-to-faculty ratio has ensured that students receive personalized attention from members of the faculty.

Vision

Our ambition is to serve as Pakistan's national law school and to be internationally acknowledged as a leader in the teaching and research of law.

Mission

The three overarching goals of SAHSOL are:

- a. to nurture future leaders of the legal profession and academia in Pakistan and abroad;
- b. to produce impactful research that promotes human rights, socioeconomic development, and the rule of law; and
- c. to develop and disseminate innovative techniques for the teaching and training of Pakistani law.

B.A.-LLB (Honours) Programme

To earn a B.A. -LLB (Hons) degree, students must complete a minimum of 162 credit hours' graduation 58 – 62 credit hours in the B.A. and 100 credit hours in the LLB.

Graduation Requirement		162 credit hours	
1	B.A.	Total	58*-62 credit hours
		University Core	8 credit hours (3 courses)
		University Distribution	
		<i>In-Group</i>	12-16 credit hours (4 courses)
		<i>Out-Group</i>	9-12 credit hours (3 courses)
		Pre-Law Core	11 credit hours (3 courses)
		Free Electives**	Courses may be taken from any School toward completion of the remaining 15-22 credit hours.
2	LLB	Total	100 credit hours (27 courses)
		Major Cores	77 credit hours (21 courses)
		Major Electives	19-20 credit hours (5 courses)

*Students are expected to complete at least 58 credits in the BA phase. The overall graduation requirement would still remain 162. Thus, students must ensure that they keep a track of their degree progress

**The number of courses needed to complete the Free Elective requirement will depend on the credit hours of the individual courses taken, which can vary from 3 to 4 credits.

B.A. Requirement: 62 credit hours

- (i) **University Core Courses:** Students must successfully complete the three University core courses: Writing & Communication (SS 100), Islamic Studies (SS 101) and Pakistan Studies (SS 102).
- (ii) **Pre-LLB Courses:** Students must successfully complete Introduction to Pakistan Legal System (LA W 102) and Introduction to Legal Reasoning (LAW 101) during the First Year of the B.A. phase, and Concept of LAW (LAW 210) in their Second Year of B.A. before they can proceed to the LLB.
- (iii) **In-Group and Out-Group Courses:** Students may take any four Economics OR HSS courses to fulfill their In-Group requirement and any three ACF/MGS, SSE OR EDU courses to fulfill their Out-Group requirement.
- (iv) **Free Electives:** Although you can undertake courses at any level, in any particular year, provided you have met the prerequisites for that course, you are advised to enroll in 100-level and 200-level courses during the B.A. phase. These courses are taught at a level of difficulty appropriate for First year students and sophomores and will enable you to achieve a good GPA. Law students wishing to take up a 300-level course during the B.A. phase are strongly encouraged to consult their Faculty Advisor before doing so. Non-Law courses offered by the Law School will be given the General Studies Law (GSL) prefix. They may be taken by students from all schools; however, they will be counted as Free Electives.

LLB Requirement: 100 credit hours

The LLB consists of 22 core/mandatory law courses (referred to as “Major Cores”), amounting to a total of 81 credit hours, and 5 elective law courses (referred to as “Major Electives”), amounting to a total of 19-20 credit hours.

The core courses listed below are required of all LLB students*.

Course Code	Course Title	Credit Hours
LAW 220	Contract Law	4
LAW 240	Criminal Law	4
LAW 222	Torts Law	4
LAW 210	Concept of Law (Pre-LLB)	4
LAW 230	Constitution (Comparative) Law	4
LAW 223	Commercial Law	4
LAW 260	Islamic Jurisprudence	4
LAW 224	Property Law	4
LAW 280	Legal Practice I: Legal Writing and Research Methods	2
LAW 310	Jurisprudence	4
LAW 352	Public International Law	4
LAW 360	Muslim Personal Law	4
LAW 331	Constitution and Administrative Law	4
LAW 320	Equity, Specific Relief and Trusts	4
LAW 353	Human Rights Law	4
LAW 322	Labor Law	3
LAW 471	Civil Procedure	4
LAW 470	Evidence	4
LAW 481A	Legal Practice II: Drafting Legal Instruments, Practitioners’ Skills and Professional Ethics	2
LAW 481B	Legal Practice III: Drafting Pleadings and Statutory Interpretation	3
LAW 482	Legal Practice IV: Advocacy	3
LAW 472	Criminal Procedure	4

*Core courses shall remain the same for the current Law Classes of 2021 and 2022. The list is undergoing curricular revision and will be revised for Law Class of 2023 and beyond.

LAW ELECTIVES:

Students also have the opportunity to supplement core courses with a variety of law electives. Although elective courses vary from year to year, the School of Law now offers a wider range of electives than ever before. Electives offer students an ability to expand their knowledge of the law to reflect the greater specialization of legal fields as well as to deepen their understanding of fundamentals. Many of these electives will have a cap on enrollment and be structured as seminars.

Following is a non-exhaustive list of some recently offered Law Electives:

In the areas of Corporate and Commercial law:

- Tax Law
- Competition Law and Antitrust
- Law and Practice of International Commercial Arbitration

Constitutional / Comparative Law:

- South Asian Constitutionalism
- Law and Politics of Freedom in Modern America
- Environmental Law and Regulations
- The Refugee in International and Pakistani Law

Criminal Law:

- Critical Legal Issues in the Global War on Terrorism
- Criminal Law Clinic

Critical Legal Studies:

- Gender, Justice and Law
- Law and Literature
- Culture, Image, Text and Law

Note: Courses that are offered by another department but cross-listed with Law (i.e. carry a law prefix as well) will count as part of the Major Electives so long as the student enrolls under the law prefix (i.e. LAW XXX).

Sample Five-Year Plan for the B.A.-LLB (Hons) Programme

Code	Course Title	Credits	Code	Course Title	Credits
B.A Phase					
First Year Fall			First Year Spring		
LAW 102	Introduction to Pakistan Legal System* University Core Courses, In-Group Courses, Out-Group Courses and Free Electives	3	LAW 101	Introduction to Legal Reasoning* University Core Courses, In-Group Courses, Out-Group Courses and Free Electives	4
Sophomore Fall			Sophomore Spring		
LAW 210	Concept of Law In-Group Courses. Out-Group Courses and Free Electives	4	In-Group Courses. Out-Group Courses and Free Electives		
LLB Phase					
1st Year Fall			1st Year Spring		
LAW 220	Contract Law	4	LAW 230	Constitution (Comparative) Law	4
LAW 240	Criminal Law	4	LAW 223	Commercial Law	4
LAW 222	Torts Law	4	LAW 260	Islamic Jurisprudence	4
	Free Elective	4	LAW 224	Property Law	4
			LAW 280	Legal Practice I: Legal Writing and Research Methods	2
	Total	16		Total	18
2nd Year Fall			2nd Year Spring		
LAW 310	Jurisprudence	4	LAW 320	Equity, Specific Relief and Trusts	4
LAW 352	Public International Law	4	LAW 353	Human Rights Law	4
LAW 360	Muslim Personal Law	4	LAW 322	Labour Law	3
LAW 331	Constitution and Administrative Law	4	XXX	<i>Law Elective**</i>	4
	Total	16		Total	15
3rd Year Fall			3rd Year Spring		
LAW 471	Civil Procedure	4	LAW 472	Criminal Procedure	4
LAW 470	Evidence	4	LAW 481B	Legal Practice III: Drafting Pleadings and Statutory Interpretation	3
LAW 481A	Legal Practice II: Drafting Legal Instruments, Practitioners' Skills and Professional Ethics	2	LAW 482	Legal Practice IV: Advocacy	3
XXX	<i>Law Elective**</i>	4	XXX	<i>Law Elective**</i>	4
XXX	<i>Law Elective**</i>	4	XXX	<i>Law Elective**</i>	4
	Total	18		Total	18

* Introduction to Pakistan Legal System and Introduction to Legal Reasoning may also be completed in the Sophomore year.

** Major Electives

Revised Plan For the LLB Phase

LLB Phase			
1st Year Fall		1st Year Spring	
1	Contract Law	1	Legal Theory (Juris & Islamic Juris)
2	Criminal Law	2	Public Law
3	Torts Law	3	Legal Research & Writing
4	Public International Law	4	Civil Procedure Code
2nd Year Fall		2nd Year Spring	
1	CrPC	1	Equity, Specific Relief and Trusts
2	Constitution and Administrative Law Labour Law	2	Human Rights Law
		3	<i>Law Elective</i>
		4	<i>Law Elective**</i>
3rd Year Fall		3rd Year Spring	
1	Evidence	1	Advocacy
2	Advanced Legal Drafting:	2	<i>Law Elective</i>
3	<i>Law Elective**</i>	3	<i>Law Elective**</i>
4	<i>Law Elective**</i>	4	<i>Law Elective**</i>

Please note that the LLB curriculum is undergoing extensive revisions. The structure and sequence of courses as described in this table is subject to possible change in the coming year.

Sequence of LLB Courses

Students must follow the sequence of LLB courses set out in the five-year B.A.-LLB (Hons) plan. Students who stray from this sequence do so at their own risk: the Law School will not accommodate requests for changes in the timetable by individual students who have missed compulsory LLB courses and are therefore not able to complete the programme within five years.

Leave of Absence

Although students who take a semester-long leave of absence during their LLB degree are allowed to resume their LLB studies the following semester after approval from the Head of Department/Dean, this is not recommended. LLB courses build upon one another, and not studying the courses in sequence will place you at a disadvantage: it is likely that you will struggle throughout the remainder of your degree. Therefore, students are advised to wait an entire academic year (two semesters) before rejoining the LLB.

It is very likely that students who take a leave of absence for one semester will have to add on an extra semester to their degree in order to complete the missed LLB courses; and students who take the entire year off will have their graduation delayed by a whole year.

Contact Details:

Contact one of the following administrators about SAHSOL policies, procedures or any other issue:

a. Ms. Nimra Parvez

Assistant Manager, SAHSOL

Email: nimra.pervez@lums.edu.pk

Ext: 8212

b. Mr. Muhammad Imran

Assistant Manager, SAHSOL

Email: mimran@lums.edu.pk

Ext: 8068

c. Mr. Khalid Mehmood Siddiqui

Assistant Manager, SAHSOL

Email: mkhalid@lums.edu.pk

Ext: 8063

Directed Course Work (DCW)

Students are encouraged to participate in a scholarly research and writing project (Directed Course Work “DCW”) in the penultimate or final year of their degree. DCW may take the form of an Independent Study, a Directed Research Project (DRP) or a Senior Project (SPROJ). Please note that students are only allowed to undertake one SPROJ during their degree programme, be it a single 4 credit hour SPROJ or a combined 8 credit hour SPROJ. Students cannot take two separate 4 credit hour SPROJs and are restricted to a maximum of 12 credit hours of DCW during the course of their degree.

Both the Independent Study and the DRP span over a single semester, consist of 4000-5000 words (including footnotes), and amount to 1-2 credit hours. They are both graded Pass/Fail. However, the Independent Study must be undertaken alone whereas the DRP may be undertaken by a group. The SPROJ may span over one semester or two, depending on the number of credit hours, which can vary from 3-8, and consists of 8000-10,000 words (including footnotes). The SPROJ can be undertaken as an independent research or by a group of students. The SPROJ is assigned a letter grade.

Although not compulsory, DCW is a valuable opportunity to engage in original research and to prepare a substantial written piece of work, which will enable you to develop transferable skills (research skills; learning to write succinctly; time-management) that are useful in your law career. Most students find that DCW is one of the most rewarding parts of their degree programme. DCW may count as part of the Major Electives or Free Electives.

DCW is predominantly independent work, and each student/group of students is assigned a supervisor to assist you in this process. Please note that the role of the supervisor is not to ‘spoon feed’ you and to teach you the topic you have chosen to research, but to help shape your ideas and to give you advice on how to conduct research. Your supervisor will expect you to be organized, self-disciplined and motivated enough to take responsibility for your own work and complete it by agreed deadlines.

The DCW topic is subject to the approval of the supervisor, who may be any member of the Law School Faculty (permanent or adjunct) under whose direction you wish to write the Independent Study/DRP/SPROJ. The following is a suggestive, but by no means exhaustive, list of potential research topics:

- An original Research Project using, for example, a set of case law on a particular legal issue.
- An original research question about a particular legal theory and its critique based on scholarly material or real-world application e.g., use of Hans Kelsen’s Pure Theory of Law for the justification of Martial Laws in Pakistan.

- A critical review of the scholarly literature on some aspect of the student's major field e.g., legal reform discourse on gender equality in Pakistan.
- An analysis of a particular statute or provision of law based on legal commentaries, case law and facts e.g., Section 4 of the Muslim Family Law Ordinance 1961 relating to the share of orphaned grandchildren in inheritance.

N.B: All students undertaking a piece of DCW are required to attend the mandatory SPROJ seminars, designed to assist students in the preparation of their work. The seminars are offered in the fall semester only and must be attended by those students enrolled in DCW in fall as well as those who plan to undertake DCW in the spring semester of that academic year. No student enrolls in DCW in spring without first having attended the fall SPROJ seminars.

Planning and Conducting DCW

Important stages in the DCW process include:

1. Choosing a topic:

DCW will consume a considerable amount of your time, so identify a topic (a broad subject area) that sparks your interest, one that you are genuinely committed to exploring. This should be done in the semester prior to beginning DCW.

2. Choosing a supervisor:

Once you have picked a topic, you should select a supervisor based on broad research interests i.e., choose as a supervisor someone whose research interests align with your topic. This should also be done in the semester prior to beginning DCW.

3. Registration:

Once your supervisor has approved your SPROJ/Independent Study//DRP/SPROJ topic, you are required to complete the DCW registration form (available from the Programme Coordinator's office as well as on the LUMS Portal), and submit it to the Programme Coordinator, who will forward it to the Office of the Registrar. The Office of the Registrar will not accept DCW forms directly from the students.

4. Writing a research proposal:

Submit an initial proposal to your supervisor explaining what you want to research, how you plan to research it, and when you will complete each task. The proposal should specify the following:

- (i) The research question: What is it that you really want to find out – what the specific problem is you want to address/specific question you want to answer
- (ii) A description of the data you will need and identification of the potential sources for obtaining it (e.g., primary and secondary sources).
- (iii) A description of the kinds of methods you intend to use to undertake your research. You may engage with theoretical or empirical research or both. For empirical research, you may employ qualitative or quantitative strategies, or use a mixed methods approach. What you choose will depend on your research question, your preferences, and your skills.
- (iv) Relevant courses and experiences that have prepared you to undertake the project.

- (v) The area of law that your proposal fits into e.g., Constitutional Law, Labor Law, Jurisprudence, Commercial Law, International Law, Islamic Law, Family Law.
- (vi) A timetable for the completion of the project.
- (vii) Division of labor if you are working as a group.

5. Recommended timeline:

You should aim to meet with your supervisor fortnightly. There should be a preliminary review halfway through your work. Below is a suggested timeline:

- (i) Submission of research proposal by the end of week 3.
- (ii) Submission of literature review/revised research questions by the end of week 6.
- (iii) Submission of first draft by the end of week 10.
- (iv) Submission of final draft by the end of week 13.
- (v) Oral defense by the end of week 14.

The above timeline can be extended over a period of two semesters for an 8 credit hour SPROJ. Your supervisor may choose to assign separate grades for each stage with no less than 75% weightage assigned to the assessment of the final draft.

6. Grading:

In general, all members in a group are awarded the same grade. However, at the discretion of the supervisor, different grades may be awarded to different group members based on objective evidence of differential performance. The supervisor may use presentations, oral defense or other such means in conjunction with the written report to assess performance. If the supervisor chooses to conduct an oral defense, this is done before members of the faculty.

In the 5 years of your undergraduate BA-LLB (Hons) degree, advising (academic & non-academic) plays a vital role in shaping not just your academic career, but goes beyond those years into your professional lives as well.

Academic Advising at SAHSOL

Advising is the mutual responsibility of an advisor and a student. Programme coordinator's office as well as faculty advisors at SAHSOL contributes in this process by helping the student understand the degree requirements, determine student's aptitude and when necessary, identify alternate academic plan. Ultimately, it is the responsibility of the student to make decision(s) about his/her academic plan. Your faculty advisors are assigned to you at the time of your admission. Their information can be seen at the 'Campus Community' tab of your Zambeel Account. In case there is no advisor assigned, please visit the programme coordinator's office, or send in your request at their respective email address.

Role of A Student for Effective Advisement:

1. Plan your next semester well in advance; make advising appointments with the programme coordinator prior to upcoming semester enrollment phases. Students are encouraged to meet the programme coordinator as well as their faculty advisors at least once every semester.
2. Do your homework for advising appointments:
 - i. Pen down your questions/concerns.
 - ii. Shortlist the courses you intend to take in the upcoming semester.

- iii. Prepare an alternate plan as well, in case, you are unable to enroll in your preferred courses in the upcoming semester.
3. Take responsibility for making your own plans and decisions. An advisor may provide advice, but s/he cannot make your academic career plans for you.
4. Use your Undergraduate Handbook to:
 - i. Understand the structure of the BA-LLB (Hons) programme,
 - ii. Review the minors from other Schools that are offered and their requirements, if you wish to do a minor along with the Law major,
 - iii. Review the programme requirements you have completed and plan for those yet not fulfilled,
 - iv. Read all undergraduate degree requirement policies.
5. Read all University correspondence sent to you via email. In case of any ambiguity, contact the concerned department and seek advice.

Role of The Advisors:

1. The programme coordinator at SAHSOL provides the necessary information about policies, procedures and requirements.
2. The coordinator as well as the faculty advisor at SAHSOL also aids a student to: a) Learn how to make practical academic plans and decisions; b) Ascertain a range of various choices available to the student; c) Think through the consequences (Pros & Cons) of his/her decisions.
3. They also help a student in the development of an academic plan consistent with the student's programme requirements, objectives, interests and abilities.

For any kind of queries related to your academic management, enrollment, major selection/change issues, section change issues, and career counseling, you can drop an email at the school's official advising email address.

Office Location: Office 1-24, SAHSOL Faculty Wing, 1st Floor Law Building

Official Email: undergradadvising.sahsol@lums.edu.pk

SYED AHSAN ALI & SYED MARATIB ALI SCHOOL OF EDUCATION (SOE)

SOE Undergraduate Academic Programmes

Minor in Education

Since the launch of the school in 2017, SOE has built its undergraduate portfolio by regularly offering courses targeting the undergraduate student body. This has culminated into the launch of SOE's first undergraduate programme: the Minor in Education. The interdisciplinary minor is intended for all undergraduate students at LUMS; students that are keen to diversify their undergraduate learning have the opportunity to engage with education discourse and broaden their understanding of issues such as education and social justice, teaching and learning, education policy and practice, education technology, the role of education in conflict settings, etc. Situated at the nexus of research, policy and practice, the innovative curriculum provides a substantial introduction to education through coursework that integrates academic and field-based learning. From a disciplinary perspective, the course content draws upon various economic, political, social, cultural, and philosophical contexts to understand foundational issues of education such as equity, reform, diversity, accountability, policy and advocacy.

The core requirements of the minor include courses on the philosophy of education and an introduction to critical debates in the field such as those surrounding issues of access and equity in education. Among the goals of the minor is to allow undergraduates to develop an understanding of the core issues facing educators and policymakers in national and international contexts, and to enable them to analyze and propose solutions to the intricate challenges of education policy and practice, especially by making connections with their major programme of study.

The school was founded with the intention of producing a new class of education leaders that will provide strategic direction to a burgeoning education ecosystem. Given that there is significant interest among the student body to explore professional opportunities in the education sector, the minor programme will facilitate real time engagement with educational challenges via the school's existing network of partner organizations.

Course and Credit Hours Distribution:

To satisfy degree requirements, students must accumulate a minimum of 18 credit hours in the area of education and secure a cumulative GPA of 2.75 in the selected courses.

Students should successfully complete a minimum of six regular courses (two core courses and four electives) in the area of education. Of the four electives, at least three should be at the 300 level or above.

In addition, all general rules and regulations announced at the university level in this Undergraduate Student Handbook must be adhered by students who are interested in obtaining a minor in Education.

1. The following two courses are core requirements for the minor (6 credits):

CODE	TITLE	CREDITS
EDU 210	Critical Debates in Education	3
EDU 213	Philosophy of Education	3

2. The remaining 12 credits (or more) for the minor may be completed by taking a combination of the following elective courses, in accordance with the rules stated above:

CODE	TITLE	CREDITS
EDU 212	Sociology of Education	4
EDU 220	Curriculum, Teaching and Learning	3
EDU 222	The Learning Gap: Critical Issues in Educational Psychology	4
EDU 250	Education in the Pakistani Context	3
EDU 252	Contemporary Social Policy Issues in Pakistan	3
EDU 262	Creating Elites and Delinquents	3
EDU 272	Educations, Schools and Violence	3
EDU 273	Education, Media and Culture	3
EDU 274	Gender Media and Education	3
EDU 312	Politics of Education	3
EDU 313	Education for Social Justice	3
EDU 314	Education and Development	3
EDU 322	Computers, Problem Solving and Cooperative Learning	3
EDU 323	Demonstrative Teaching of Science and Math	3
EDU 324	Effective Teaching and Learning in Higher Education	3
EDU 325	The (Instructional) Core and How to Work it	3
EDU 326	Foundations of Education Technology	3
EDU 327	Technology and Culture	3
EDU 328	Educational Technology and the Learning Sciences	3
EDU 342	Entrepreneurship and Innovation in Education	3
EDU 343	Leading Schools: Introduction to Educational Leadership	3
EDU 352	Education Policy Analysis	3
EDU 353	Education and Conflict	3
EDU 354	Comparative & International Education	4
EDU 355	Education and Sustainable Development	3
EDU 362	Monitoring and Evaluation in Public Policy	3
EDU 363	Could Education be Bad for Society?	3
EDU 372	Mobile Lives: Im/migration and Education	3
EDU 412	Economics of Education	3
EDU 452	Human Capital and Economic Development	3

Note:

- All EDU courses begin at the 200 level; therefore, all EDU courses are closed for First year students.
- Students enrolling with the cross-listed course code from the list of courses above will qualify for minor declaration after review by the Department for completion of minor requirements. Some selected courses from other schools will also qualify as minor – approved elective courses. A steering committee comprising of SOE faculty will convene at the start of every semester to approve courses.
- Students have the option of enrolling in directed course work with the EDU code. Students may enroll in either an independent study or a directed research project of one or two credits under supervision of an SOE faculty member. This is graded Pass/Fail and does not count towards minor requirements.
- The first student batch to officially graduate with the minor will be the batch of 2022. In case a graduating student manages to complete their minor requirements earlier, their case will be considered on an individual basis.

Contact Resources:

Please contact one of the following administrators for information regarding the undergraduate minor programme at SOE: -

School of Education		
Designation	Name	Email ID
Interim Dean SOE	Dr. Faisal Bari	bari@lums.edu.pk
Director Academic Programmes	Dr. Tayyaba Tamim	tayyaba.tamim@lums.edu.pk
Programme Associate - Academics	Fatima Khan	fatima_khan@lums.edu.pk
Academic Coordinator	Arslan Sajid	arslan.sajid@lums.edu.pk



Administrative Offices & Campus Facilities

ADMINISTRATIVE OFFICES

OFFICE OF THE REGISTRAR (RO)

The Office of the Registrar (RO) handles the academic administration of the University.

Some of the major tasks and functions of this office are:

1. To maintain records and security of student data, academic and personal, using state -of-the-art information management solutions
2. To develop University wide academic calendar entailing detailed timeline for all academic activities throughout the year
3. To update and maintain course catalogues for effective and timely execution of student course registration and enrollments
4. To maintain and implement up -to-date classes' and final exam schedules for smooth conducting of classes
5. To oversee grading of courses, projects, theses, and dissertations
6. To convene the University -wide curriculum committees and act as custodian of all policies and procedures of the academic programmes
7. To publish and update the Undergraduate and Graduate Student Handbooks
8. To process graduation audit and honours & awards at the time of graduation
9. To issue transcripts, clearance certificates and degrees and provide attestation of documents and process educational verification requests by external organizations and other universities
10. To lead the Annual Convocation
11. To liaise with international and national regulatory authorities such as Higher Education Commission (HEC) to enforce and maintain policies and best practices

Services in point no.9 above may be availed by visiting <https://www.roservice.lums.edu.pk>

In case of other queries, students may email at helpdeskro@lums.edu.pk

OFFICE OF ACADEMIC ADVISING

Goal of Advising At LUMS

Students at LUMS have a range of options and opportunities available to them, as detailed in this Handbook. The goal of advising is to ensure that students are informed about the options they have, and are supported through the decision-making process, so that they can tailor their undergraduate experience according to their individual circumstances.

Mechanisms of Advising

Each school at LUMS has designed an advising system that seeks to provide students with the appropriate information and support. Depending on the school, this advising system may involve faculty advisers, staff advisers, and peer advisers. Further, most schools have different advising -expectations and advising-supports depending on the class year (first-year, sophomore, juniors, senior, super -seniors).

The Role of the Office of Academic Advising:

The Office of Academic Advising is a new central university office that works closely with schools as a thought-partner as well as a standard-setting and capacity-building partner. More specifically, the Office plays the following roles:

1. Thought-partner: the office works alongside schools to support them in advancing their advising-related goals and thinking through advising-issues alongside colleagues at each school.
2. Standard-setting: the office works with all schools and stakeholders at LUMS to identify university-wide standards and goals for advising at LUMS.
3. Capacity-building: the office collaborates with each school on building capacity to meet university standards and goals for advising.
4. Stakeholder input: the office gets input from all stakeholders (students, faculty, staff and alumni) to identify advising needs and ways of meeting these needs.
5. Finally, the office can work with individual faculty, staff or students to connect them with advisers in their schools in response to a situation.

Contacting the Office of Academic Advising:

The first point of contact for advising issues should be school advising staff. The details of each school's undergraduate advisement structure is given within the sections for each school within the Handbook. For any issues connecting with school advisers, or for suggestions for the advising system at LUMS, students, faculty, and staff can email the Office of Academic Advising at advising@lums.edu.pk.

OFFICE OF PROGRAMME ENHANCEMENT (OPE)

The Office of Programme Enhancement is the institutional research office with a mission to support quality assurance and to assist the evaluation and planning efforts of the University's senior administration. The office aims to achieve its mission by supporting internal quality assessment mechanisms that involve periodic review of academic programs as well as collection, analysis and reporting of institutional data for various stakeholders. OPE acts as the university's primary interface with the Higher Education Commission on matters related to quality assurance. In addition, it is responsible for coordinating with organizations like QS and Times Higher Education for placement of LUMS in the world university rankings.

OPE can be reached at ope@lums.edu.pk and on 2269, 2113, 2248, 2289 and 2165.

OFFICE OF INTERNATIONAL AFFAIRS (OIA)

OIA is responsible for coordinating, developing, and expanding the scope of the university's global footprint and international initiatives. The Office acts as a liaison between internal and international entities, facilitates international collaboration in line with global standards, and serves as the source of international opportunities, information and resources. OIA also consults and advises at all stages of partnership development, including identifying funding opportunities, hosting visitors and delegations, and coordinating exchanges with internal and external institutions.

Vision/Mission

The Office of International Affairs (OIA)'s mission is to give strategic and operational direction to LUMS' continuing internationalization. It is focused on building sustainable and mutually beneficial international partnerships that promote quality education and research by initiating and facilitating individual and institutional connections between LUMS and international students, faculty, and staff.

Through greater global engagement the OIA aims to increase the visibility and impact of LUMS around the world. OIA's goal is to create global learning opportunities on campus and abroad, bring international resources on campus, cultivate partnerships and connections with global institutions, and engage its alumni across the world. It is vital for institutions in today's world to maintain a committed, meaningful interaction with the world as a whole and that is what the OIA aims to practice and endorse.

Key Services

The Office of International Affairs is a hub for information about LUMS' international activities. In particular students should contact the OIA for information on study abroad programs, international exchanges, and summer programs. In particular OIA:

1. Provides information about potential international exchanges and other international mobility opportunities;
2. Delivers guidance and support on international exchanges and international mobility; OIA works with students who are interested in participating in a **non-LUMS term time or summer for-credit study abroad** experience;
3. Oversees and manages LUMS' global partnerships, and supports and facilitates global activities for students, faculty and staff;
4. Ensures engagement in all areas of international student affairs, ranging from recruitment and admissions to student support.

Important department specific information

The OIA currently manages 51 student exchange programs with leading international universities around the world. Through these programs LUMS students can attend exchange programs and study abroad for a semester or the summer, sometimes on partially or fully funded scholarships.

A selection of our partner universities:

- FH Joanneum University of Applied Sciences, Austria
- Huazhong University of Science and Technology (HUST), China
- Koç Üniversitesi, Istanbul, Turkey
- Middle East Technical University – METU, Turkey
- National University of Singapore (Summer Programme), Singapore
- Seoul National University (SNU), South Korea
- SOAS University London, UK
- Tilburg University, Netherlands
- Universiti Putra, Malaysia
- University of Ulsan, South Korea
- University of Malaya (UM), Malaysia
- Universiti Teknologi Malaysia (UTM), Malaysia

- University of Passau, Germany
- Universiti Brunei Darussalam, Brunei

By promoting internationalization, the OIA helps LUMS to develop global citizens who can positively contribute to making our world a better place. Through global engagement LUMS students gain invaluable insights into world affairs and international problems, as well as perspectives and skill set that set them apart from other Pakistani graduates. Students are graduating into an increasingly integrated international environment that, while offering exciting opportunities, also presents many challenges. Through internationalization LUMS creates educational environments where students fully appreciate the complexity of global integration and develop skills to navigate it successfully.

Contact Details

Dr. Waqar Zaidi

Director, Office of International Affairs

Associate Professor History, Department of Humanities and Social Sciences

waqar.zaidi@lums.edu.pk

Zainab Masood

Deputy Manager, Global Engagement

Office of International Affairs

zainab.masood@lums.edu.pk

Gulmeena Roghani

Programme Officer, Global Engagement

Office of International Affairs

gulmeena.roghani@lums.edu.pk

Facebook: <https://www.facebook.com/OIALums/>

Twitter: https://twitter.com/office_lums

Instagram: <https://instagram.com/internationalofficelums>

<https://osa.lums.edu.pk/incoming-exchange-students>

OFFICE OF ADMISSIONS (OA)

The Admissions Office is responsible for admissions at LUMS. The university is keen to attract students who are not only academically competent but also have the potential to contribute to the learning environment of LUMS. First year students are inducted only once a year i.e. in Fall semester. Admission in LUMS is purely merit based. At the undergraduate level, students are admitted to a specific school from the beginning of their programme. Admission in a specific major/school is based on merit, preference given by the applicant and the availability of seats.

Important Information:

- Students applying as First year students will not be eligible to receive credit of any course(s)/subject(s) studied earlier at school, college or university level.

- Students who have completed 12 years of education which does not lead to FA/ICS/ICOM/FSc are required to get an equivalence certificate from the Inter Board Committee of Chairmen (IBCC), Islamabad, Pakistan.
- Students admitted to LUMS and subsequently require HEC attestation of their UG degree must meet the conditions stipulated by the Higher Education Commission (HEC), Pakistan to get their Undergraduate degree attested. Details are available at the following link: <http://hec.gov.pk>

In addition to the conditions stipulated by the LUMS (mentioned in offer letter), students are liable to meet the requirements specified by the Inter Board Committee of Chairmen (IBCC) &/ Higher Education Commission (HEC), Pakistan & /Pakistan Engineering Council (PEC) or any other relevant authority for the verification of their academic credentials. Affairs pertaining to equivalency/attestation/ verification with IBCC/HEC/ any other organization are handled by students on their own.

OFFICE OF FINANCIAL AID (OFA)

Admission to all programmes is purely on merit and independent of students' ability to pay the related tuition fees. Once a student has been admitted to a programme, there are several mechanisms in place to provide financial support based on need and merit. All awards are reassessed each academic year based on performance, need, available resources and prevailing University policies. LUMS is committed to providing as much financial assistance as possible within the limits of its available resources. Nevertheless, the University may not be able to meet all requests for financial assistance, and it is strongly recommended that applicants secure as much of their own funding as possible.

Indeed, from its very inception, the Lahore University of Management Sciences (LUMS) has tried its best to make quality education accessible to all students in Pakistan, including those from low and middle-income households. Since inception LUMS has disbursed more than PKR 6.8 Billion in financial assistance to its students. Currently, approximately 35% of the students at LUMS get some form of financial assistance from LUMS based on the assessed financial need.

Types of Awards

Several merit and need-based scholarships are available for students who meet specific criteria;

1. Merit Scholarships
2. Need based Tuition Fee Waivers and Loans
3. National Outreach Programme (NOP)
4. External Scholarships
5. International Scholarship

1. Merit Scholarships

LUMS not only recognizes students' good academic performance but also distinguishes high achievers by providing them **generous Merit scholarships**. If you are a high achiever, LUMS wants you to accomplish everything you possibly can. Exemplary students are selected to receive **LUMS Merit Scholarships** on the basis of their outstanding academic performance.

First Year

100 scholarships are available to support the academic aspirations of prospective top ranked undergraduate students based on the LUMS admission evaluation ranking.

For the first year, Merit scholarship awards cover full and partial tuition fee for One (1) year and are awarded to the top students of admitted batch in each school. There is no separate application for the scholarship. Students are automatically considered for the award when they apply for admission to LUMS.

Subsequent Years

Merit scholarship awards cover partial to full tuition fee and lab charges (where applicable) for one year only and are awarded to the returning Batches who are placed on Dean's Honour List based on their academic performance. The number of scholarships is subject to approval and may vary each year.

Note: In case a student qualifies for both financial aid award and any other scholarship, s/he will receive the higher aid benefit. These awards are for one (1) year only and cannot be carried forward to subsequent years.

2. Need based Tuition Fee Waivers & Loans

These awards are available in the form of tuition fee waivers and loans. They cover partial to full tuition fee expenses of the programme. For Undergraduate SBASSE students, it also includes the lab charges. These awards are reassessed in each academic year based upon performance and demonstrated financial need.

The range of the amount of financial assistance over the last year for the Undergraduate Programmes has been between 20% - 130%.

3. National Outreach Programme Scholarship (NOP)

LUMS launched its National Outreach Programme (NOP) in 2001 to extend the benefits of world-class education to talented students all over Pakistan and thereby become a truly national university. This prestigious scholarship programme focuses on identifying bright students with exceptional academic record and from highly underprivileged backgrounds whose families cannot afford to support their children's university education. The scholars that qualify are provided full funding that includes total tuition waiver and a stipend to meet all other expenses. For details, please refer to www.nop.lums.edu.pk.

4. External Scholarships

External Funding is available in the form of full as well as partial scholarships for deserving students based on need and merit. Students are shortlisted for external scholarships based upon eligibility criteria specified by the donors. Each Scholarship has its own specifications and preferences.

5. International Scholarship

Shahid Hussain Foundation Scholarships are available for applicants who are nationals of SAARC member countries.

University reserves the right to amend, cancel or terminate the awarded financial aid in case of any misrepresentation or incorrect information provisioning. Misrepresentation may also lead to termination from the programme.

WHEN TO APPLY

First Year

Students can apply for financial assistance for the first year simultaneously with the admission application. Application for financial assistance has no bearing on admission decision. Independent applicants at later stage are not considered in this regard.

Subsequent Year(s)

Financial aid for students is reassessed every year. In order to continue the financial aid award in subsequent years, students must apply for financial aid each year on or before the dates specified by the Office of Financial Aid. The process is conducted at the beginning of each year where students are approached by OFA to submit the requisite forms and documents. Failure to comply the given deadlines for document submission could lead to cancellation of financial aid.

It is the responsibility of the students, who are on financial aid to provide updated information of their family financials in case of any positive change and get their financial aid adjusted.

Appeals on the basis of Special Circumstances

Only those students whose financial situation changes drastically due to unforeseen circumstances (e.g. parent/ guardian retirement, death, layoff from job etc.) can apply for financial assistance during the year. It is compulsory to provide evidence in case of any change in the financial situation. Adherence to the deadline specified by the Office of Financial Aid is mandatory, otherwise the application may not be considered.

Fee Installments and Deadline Extensions

Requests for Fee Installment and Deadline Extensions are processed by the Office of Financial Aid (OFA). Students who are unable to pay their University dues, due to financial constraints or any other reason, can apply for the said facility.

Process to Follow

The deadline to file for Fee Installments and Deadline Extension is communicated to the entire student body through a University wide e-mail routed through the Office of Student Support Services (SSS). The requisite forms are available on Zambeel. The following documents are required to be online with the form:

- Latest Salary Slip/ Income Certificates/ Pension Books / Income Tax Return for the current year
- Bank Statement for the last six months
- Any other document to help us ascertain your request for Fee Installments and Deadline Extensions.

All the above stated documents may not apply. They may vary from case to case.

Loan Facilitation Office (LFO)

The Loan Facilitation Office (LFO) is a sub section of the Office of Financial Aid (OFA) that aims to educate the student body regarding LUMS Interest Free Loan and also ensures the smooth functioning of the loan disbursement process. It strives towards inculcating the moral value of paying back on time through group and individual meetings.

In order to facilitate students availing LUMS Interest Free Loan, LFO has introduced the Flexible Loan Repayment Plan through which a student can pay any amount out of the total disbursed loan during their study tenure through flexible payment options. Students are given an option to repay the loan as per their convenience during their studies on voluntary basis in order to lessen the overall loan burden at the time of graduation.

Note: The Flexible Loan Repayment Plan is an entirely non-obligatory initiative by LUMS hence it does not stand binding on the student but remains optional for them.

LUMS NATIONAL OUTREACH PROGRAMME (NOP)

LUMS aims to provide equal academic opportunities to people from all social walks of Pakistan. In order to fully harness the potential of the human resources of the country, LUMS has provided a broader access to its Programmes across the four Provinces. In light of the above, the LUMS National Outreach Programme (NOP) was launched in 2001, with the aim to extend the benefits of a world-class education at LUMS to brilliant yet underprivileged students from all over Pakistan. In addition, a prevalence of continuous mentoring and guidance is ensured so that these aspiring students obtain a level playing field to compete with the larger cohort.

The Success of the NOP

With the success of this Scholarship Programme, over 1200 students have been inducted so far with not only a 100% waiver on tuition & admission fee but this benefit has also been extended to the provision of hostel fee, stipend for living and book allowance. Out of these, more than 600 graduated young scholars are out in the world achieving their dreams and making an impact in their communities. Some are working in leading companies across the globe or are running successful entrepreneurial ventures. Some are pursuing Higher Education at renowned institutions worldwide and more than 40 Scholars have received prestigious international scholarships. For these students, throughout their tenure at the University, the LUMS NOP Centre not only provides scholarship opportunities but guides students through the entire admission pipeline including pre-admission coaching. The Centre's role is pivotal not only during the induction process but even after students have been inducted into the LUMS Undergraduate Programmes as NOP Scholars.

The NOP Pipeline

Recruitment into the NOP begins with Outreach whereby the Centre reaches out to bright students across all provinces to encourage them to apply to the NOP Summer Coaching Session (SCS). The SCS is an intensive academic training session through which shortlisted candidates are prepared for Admission at LUMS and given a taste of life at a university. The Centre then guides successful attendees of the session to take the LUMS Admission test and fill out admission applications alongside the regular cohort. Throughout the pipeline, a systematic stream of correspondence is maintained with candidates until they become NOP Scholars and even beyond that.

Student Support at NOP

NOP Scholars and other students have the facility of talking to a dedicated Student Counselor. Counseling takes place in the context of a helping relationship in which the counselor and the student work together in an open environment to resolve a problem, change behavior or foster personal growth and awareness. Counselling sessions help students cope with the academic rigor and personal challenges they may face at LUMS.

The counseling relationship is confidential. All the information gathered by the counselor stays within the Centre. No information is released without a student's written consent, unless they are an immediate danger to themselves or others. Constant follow-up is made to ensure all those who receive counselling are in essence, finding ways to address their problems. The Counselor also ensures coordination with your Faculty Advisor for guidance on academic and social matters.

The Counselor can provide guidance on a variety of matters which include but are not limited to the following:

- Bereavement/ Loss
- Home Sickness
- Substance Abuse/ Addictions
- Feeling disconnected and stressed
- Struggling to develop habits such as time management, prioritization and staying healthy
- Acclimating to academic expectations that may be more challenging than anticipated
- Managing a level of social and cultural diversity that may be different from the communities with which you are most familiar
- Interacting with the opposite gender
- Comparing oneself to others and becoming discouraged
- Having difficulty managing relationships, both at home and at university
- Abuse/ Harassment
- Increased Personal Responsibility
- Financial Challenges etc.

The counselor can be reached at sadia.babar@lums.edu.pk to set an appointment any time between 09:00 AM to 05:00 PM PST (Monday to Friday).

Collaborations at the NOP

The NOP Centre routinely comes together with various stakeholders at and beyond LUMS to provide skill-enhancement opportunities to NOP Scholars. One such collaboration is the year-long commitment with the MGSHSS Learning and Mentoring Center that offers Academic Writing and Comprehension classes for first year scholars in order to improve their skills. Similarly, the Career Services Office (CSO) and external trainers are partnered with for the provision of career preparatory trainings throughout a student's tenure at LUMS. The Centre is also working closely with the Unit of Academic Advisement and OSA to foster social integration within the LUMS community.

Contact Us

The LUMS NOP Centre has an open-door policy. In case you need help you can walk into the Centre at any time between office hours (8:30 am – 5:00 pm) from Monday to Friday. We are more than happy to assist you.

Location: NOP Centre, 2nd Floor, PDC Building, LUMS

Phone: +92 42 3560 8000 Extension: 2419

Website: www.nop.lums.edu.pk

Email: nop@lums.edu.pk

OFFICE OF ACCESSIBILITY AND INCLUSION (OAI)

LUMS takes pride in the diversity of its community. With students, staff and faculty coming from all corners of the country and beyond, the University is an intellectual hub rich with varying perspectives and transformative ideas. The LUMS community welcomes members of different ethnic and religious minorities, the transgender community, those who struggle with physical disabilities and learning disabilities, and aims to be a safe haven for all.

The Office of Accessibility and Inclusion (OAI) has been set up as a means to fulfil this commitment and is dedicated to the inclusion of all members of the community. It aims to provide individuals with disabilities as well as vulnerable and minority groups an equal opportunity to participate in the University's programmes, benefits, and services as their peers and empathetically addresses any issues that might be hindering their life on campus.

Work at the Office is informed by conversations, input and perspectives from students, staff and faculty throughout the University resulting in initiatives that are impactful and bring members of the community closer together.

The University recognizes that each individual is unique with a specific set of challenges and continues to evolve into a campus that is accessible and accommodating for everyone. From women scholarships to accessible restrooms and assistive technologies, LUMS aspires towards a No-Borders agenda; a commitment that no obstacle should come in the way of any individual, from fully experiencing LUMS and the opportunities it has to offer.

Focus Areas

Gender Sensitization

Women, men and members of the transgender community, all experience the campus differently. A female student, a male member of the faculty or a transgender staff member might all move through the campus with completely different vantage points. In order to create understanding and empathy for each other's experience and the challenges it entails, the Office of Accessibility and Inclusion plans to expand on existing gender sensitization trainings on campus and organize relevant seminars and workshops for everyone on campus.

Accessibility

The Office is determined to make all spaces on campus accessible to people with disabilities. Each disability has its own unique challenges which is why the work being done in this regard is two-fold. OAI is working on making the campus more accessible to people with physical disabilities; we also looking into assistive

technology to help students with learning disabilities excel in their classes and learning assistants for students with visual or hearing impairments. Currently, OAI has provision for learning assistants to help any student who may require help in moving across campus, taking notes in class, or other hurdles that may become easier with the help of a friend. Please email us at oai@lums.edu.pk for more information on how to arrange a learning assistant.

Awareness and Dialogue

A free exchange of ideas is at the heart of the educational experience at LUMS and results in life-changing collaborations, groundbreaking research and transformative initiatives. Building on the University's culture of genuine conversations and dialogue, the OAI plans to have students, staff and faculty interact and engage with each other in a safe and supportive environment. The aim of these initiatives is to provide the LUMS community the space to share their experience, challenges and concerns as they navigate their life at the University. The hope is that these conversations will further foster awareness and empathy within the community members for each other's varying experiences and individual struggles.

Sexual Harassment Inquiry Committee (SHIC)

The members of the LUMS community are governed both by LUMS' own harassment policy, which is an amalgamation of the HEC Policy as well as the Protection Against Harassment of Women at Workplace Act, 2010.

A victim of sexual harassment has the right to bring either an informal or a formal complaint to the Sexual Harassment Inquiry Committee (SHIC). Informal complaints are usually resolved through mediation, while formal complaints can include penalties from community service and mandatory counseling to expulsion or ban from campus, depending on the particular circumstances.

The SHIC works to resolve cases as quickly as possible, and ideally (assuming full cooperation of all parties) within 30 days. The procedure for a formal complaint look something like this:

FORMAL COMPLAINT PROCESS CHART

OFFICE OF ACCESSIBILITY AND INCLUSION – LUMS

- The complainant fills out the official sexual harassment questionnaire and submits it to harassment@lums.edu.pk
- Provide as much relevant evidence as possible, such as text communication, photos, or videos, as well as a list of potential witnesses.
- Both the complainant and accused may be accompanied with a representative to support them throughout the proceedings. This person need not be a lawyer, they can be a family member or close friend.

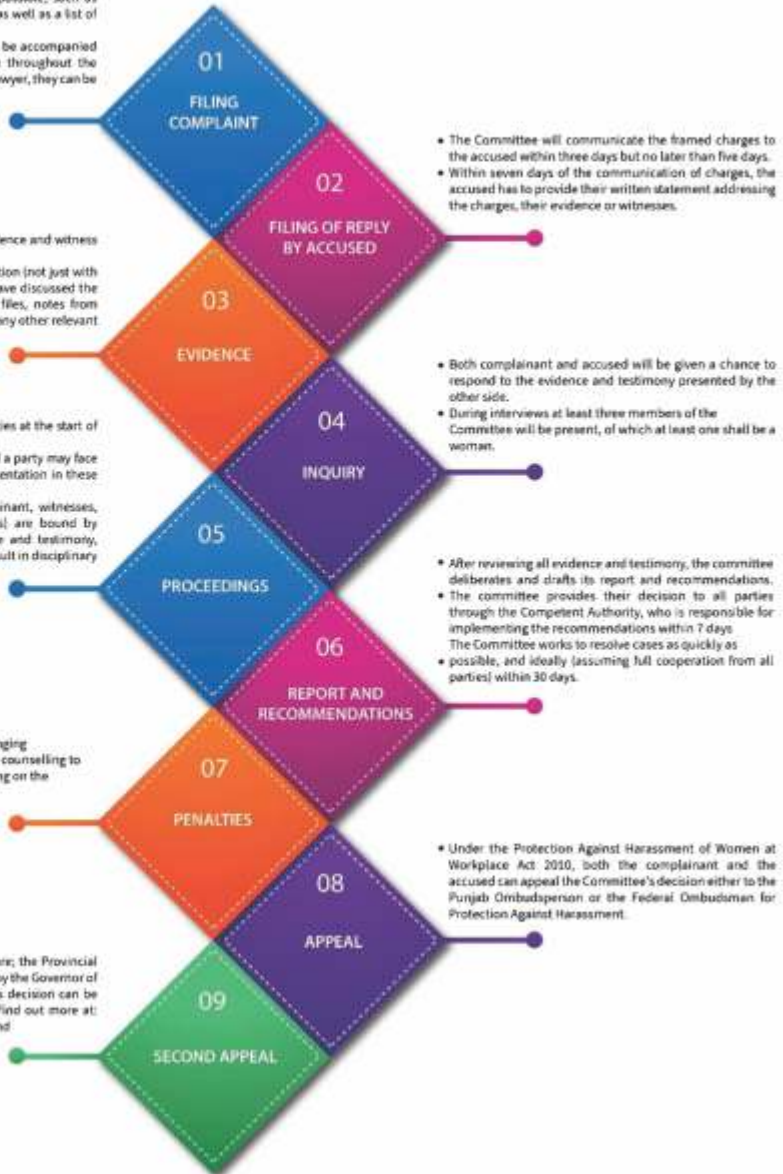

Filing a Complaint: Things to Know

- An informal complaint can be turned into a formal complaint at any time.
- It is paramount that you provide as much and as complete evidence as possible regarding your case. This may include digital communication (not just with the accused, but with others you may have discussed the case with), photographs, videos, audio files, notes from healthcare providers and counsellors, or any other thing you can think of that is relevant.
- Both the complainant and accused can appoint a representative to support them throughout the proceedings. This person need not be a lawyer, they can be a family member or close friend.
- A case cannot be filed on someone else's behalf, nor should any person be pressured into filing a case.
- During an inquiry, involved parties are under a no contact order and must not communicate with each other, even indirectly or through a third person.
- In a formal complaint, all interviews take place under oath, and any party may face disciplinary consequences for lies or misrepresentation in these interviews.
- During interviews at least three members of the Committee will be present, including at least one woman. An interviewee can request only male or only female Committee members to be present if desired.

All parties (the Committee, the complainant, witnesses, the accused, representatives) are bound by strict confidentiality regarding evidence and testimony, and breaching this confidentiality can result in disciplinary consequences.

OFFICE OF STUDENT AFFAIRS (OSA)

Office of Student Affairs (OSA) at LUMS reaches out to students, inculcates in them feeling of belonging to a community and facilitates them in making sound social and academic judgments while promoting their emotional and physical wellbeing so that it fosters intellectual growth, integrity and a sense of responsibility in them. The OSA is a central place on campus; major responsibilities are life advisement, announcement to students, sports wellness and recreation (SWR), hostels and career services office (CSO).

Student Support Services (SSS)

The Office of Student Support Services provides guidance, support, and administrative assistance to students and is a great place to visit with any questions you may have while studying at LUMS. The office coordinates important events including Orientation Week and Convocation Ceremony. The SSS also acts as ex-officio for the Re-admissions and Appeals Committee, the Disciplinary & Appeals Committee, assessment and processing of all course/semester withdrawal related cases and Missed Exams/instruments petitions.

The Office of Student Support Services is also responsible for the following student services:

- **Career Services Office (CSO)**

Career Services Office, operates under the umbrella of Student Support Services and offers an ever-increasing range of services to undergraduate and graduate students in all areas of career planning, including jobs, internships, and higher education placements. It facilitates employers to identify appropriate candidates and connects students with successful professionals from multiple industries,

which helps them develop their professional skills and match their skill set with the needs and requirements of potential employers.

The Office envisions to be recognized as a premium career service provider, facilitating LUMS students and graduates to pursue optimal academic and professional careers, while inculcating ambitious policies & practices and maintaining the highest degree of personal and professional integrity in our endeavors. For career progression, we aim to place our graduates in professionally developed organizations and provide a platform for our students to interact with renowned professional trainers of the industry to enhance their skill set at advanced levels.

For guidance regarding jobs, internships, higher education abroad and queries about careers, you may approach us at cso@lums.edu.pk.

- **LUMS Medical Center**

The LUMS Medical Center is a 24 hours emergency medical treatment center on campus. Manned by one doctor, supported by one male and female nurse at all times, this is a four-bed facility equipped with most major equipment, such as ECG machines, Glucometers, Oxygen provisions and other vital signs apparatus, providing life-saving treatment to our campus community, including a diverse community of 5000 students, faculty, staff and guests.

- **Loan Rehabilitation**

LUMS offers a substantial amount of financial aid and scholarships and though scholarships and financial aids are always preferred as they do not require repayment, but even with scholarships and financial aid on offer, many students face a gap in their university funds that may require a student loan.

Students at LUMS receive loans on special terms and provisions with zero interest, that make them a more affordable and manageable commitment for young university-bound students.

The Loan Rehabilitation department facilitates repayment of these loans from students once they become due. It may assess any deferred payment or repayment grace period options following graduation in order to relieve any evident financial pressure on these students. All such cases are assessed, verified and processed through Loan Rehabilitation section.

On-Campus Residence

The Office of Student Support Services (SSS) supports the academic mission of LUMS by providing a well-maintained residential environment for learning that respects and appreciates individual differences and promotes a sense of community. It deals with all aspects of on campus residence including student housing, accommodation, room change requests, and repairs and maintenance. The Housing Office staff ensures that students have safe and comfortable environment and enjoy their on campus residence.

- New students apply for on campus residence along with their admission and returning students register for accommodation for the next academic year in March-April.

- Non-payment of hostel fees, failure to check in without prior notice at the beginning of any academic term, or ceasing to be a registered fulltime student may result in cancellation of residence.
- On campus residence dues are non-refundable. Security, registration must be paid by all residents. Laundry charges are paid by students directly to the vendor.
- Space is allocated for one year and rooms must be vacated at the end of the academic year. Students must sign the housing agreement at the time of check in and formally complete a check out prior to vacating their room at the end of academic year.

LUMS on Campus Residency Policy and Code of Conduct

- On Campus Residence is provided to facilitate out-of-city students. Lahore residents are not eligible for On-Campus Residence at first hand. They can apply only when registration of hostel for Day scholars are announced depending on the availability of spaces in hostels. First priority is given to the outstation residents.
- Accommodation is provided to students of each programme with regard to the respective specified duration to each programme. Maximum duration; PhD/Law 5yrs, MS, MBA 2yrs, undergraduate 4years.
- Only full-time students maintaining a full course load are entitled to On Campus Residence. Students, not maintaining a full course load during any semester forfeit their residence privileges.
- Students who have completed the minimum graduation requirement of their respective programme but are enrolled in further courses will only be considered for accommodation subject to availability of space.
- Students vacating the hostel before the completion of their respective programme forfeit the right to On Campus Residence.
- Students have to vacate rooms immediately after the last scheduled exam. Room keys must be returned to the Housing Office before leaving the campus.
- Students engaging in willful abuse or destruction of University property will result in being reported to the Housing Office and disciplinary action is taken against such cases.
- Tampering with or modifying electrical, plumbing, cable television, telephone, security systems in rooms or public areas is prohibited. For a detailed Hostel LAN Usage policy, please refer to the Information System Technology (IST) section.
- Misuse of fire extinguishers or other emergency/security equipment is prohibited and subject to fines and damage charges.
- Drilling, nailing or painting of walls is prohibited.
- Permanent installation of carpets or flooring is also prohibited.
- The possession or use of fireworks, ammunition, hazardous or explosive material, firearms, pellet and BB guns, illegal knives, blades or other dangerous weapons on-campus is prohibited.
- Objects or substance of any kind may not be dropped or projected in a manner that may harass or endanger any person or risk damage to any property. Students must occupy the room to which they are assigned.
- Any changes in room assignment must have prior approval of the Housing Office and the responsibility for the assignment of rooms is at the discretion of Housing Office.
- Upon confirmation that the student is not occupying his or her room, the space of that student is reassigned after one week of commencement of classes.
- Ragging of newcomers inside the hostels is strictly prohibited. Any violation is dealt with severity.

- All residents must carry their smart cards all time.
- The residents should take care of their personal belongings. The University shall not be responsible for any loss or damage of the personal belongings of the residents.
- Accommodating overnight guests, day scholars, outsiders and visitors is not allowed. University has zero tolerance policy for illegal stay. This will lead to reporting to the OSA Housing Office and disciplinary action.
- Day scholars are not allowed to stay in the hostels. If found, student is charged a fine as per policy. They can visit hostels from 8:30 am to 10:30 pm.
- Males are not allowed in female hostels and vice versa. Any breach of this policy is considered a serious offence.
- Keeping pets in the rooms or the Residential buildings is not allowed.
- Misuse of fire extinguishers will result in a fine of PKR 2,000 per occupant of the entire floor.
- Key Replacement Charges are applicable as per policy.

University Access to Resident Rooms

- The Housing Office staff may enter a student's room without prior notice or permission at any time for administrative, safety, and regulatory purposes with the permission of Dean/HOD Housing - OSA.
- The lock of the main door of the room may not be changed nor can additional locks be placed on any door of the room, or any other doors within the building. In the event of an emergency, the University may remove students' belongings for cleaning, repair, storage, and/or protection.
- LUMS recognizes the importance of student's privacy of student rooms. Any right of entry shall be exercised only when required for purposes of health, safety, and maintenance, and to regulate the use of its premises in accordance with University rules and regulations.
- When a student sends a repair request to repairs it is understood that the Facilities and Engineering personnel have permission to enter the student's room. However, a student may specify in their request that the staff must enter in their presence only.

Substance Abuse

- **Smoking**
Smoking is a hazard to the health and safety of all residents and is prohibited in all areas of the Residential buildings. Violations are considered a breach of discipline and a fine of PKR 1,000/- is levied.
- **Narcotics/Alcohol**
The use of any kind of narcotics or alcohol is absolutely forbidden on University premises. The use or possession of any kind of narcotics/alcohol will result in disciplinary action in accordance with the Student Handbook and the possibility of immediate cancellation of residential space.
- **Sheesha**
The possession and/or use of Sheesha is forbidden on campus. Possession or use will result in confiscation of the Sheesha and disciplinary action including the possibility of cancellation of On-Campus Residence.

Note: LUMS and Housing Office reserve the right to On Campus Residence and to modify the On Campus Residence policy as and when it deems necessary.

For On campus residence related problems, contact at residence@lums.edu.pk

Campus Climate

Campus Climate is the measure of the real or perceived quality of interpersonal, academic, and professional interactions on a campus and consists of the current attitudes, behaviors, and standards of faculty, staff, administrators and students concerning the level of respect for individual needs, abilities, and potential. A healthy climate is grounded in respect for others, nurtured by dialogue between those of differing perspectives, and evidenced by a pattern of civil interactions among community members. Campus climate includes the experience of individuals and groups on a campus and the quality and extent of the interaction between those various groups and individuals. Diversity and inclusion is one aspect of the LUMS campus climate.

The Campus Climate Unit:

- Champions innovative approaches to address concerns that result in action and foster a climate that unites faculty, staff and students in shaping an inclusive learning, working and living environment.
- Honours the diversity of the campus community and ensures that distinct voices and viewpoints are heard and woven into the fabric of LUMS.
- Advises campus leaders and the campus community in developing and promoting data and research driven best practices to create a welcoming and inclusive environment for all.
- Oversees, advises, and provides professional development to student affairs related areas such as the student council, various student societies, hostel life, and the civic engagement and leadership programme.

Campus Climate Unit Initiatives:

- Hostel Life Fellows (HLF) Programme
- Ownership Week #IamLUMS
- First Year Experience (FYI)
- Civic Engagement and Social Impact
- Leadership Certificate and Portfolio
- Ethics, Values, and Morality modules

The Campus Climate Manager, with the Dean of Student Affairs Office at LUMS is Hiba Iqbal Zakai and she is reachable at the following email: hiba.iqbal@lums.edu.pk and extension: 8122

Co-Curricular Activities Office (CCA)

Co-Curricular Activities Office (CCA), Office of the Dean Student Affairs caters to activities like student leadership and organization, keen interest and involvement, teamwork and collegiality, and highest standards of integrity and transparency. CCA monitors the administration and discipline in the student-run societies and provides them the logistical support. It also provides organizational and documentation to help taking while avoiding any circumstances which may clash with University policies.

If a student is proceeding to participate in an event which is considered prestigious by the university, the patrons of the relevant societies/clubs should try to negotiate a date for the event with the event organizers that do not conflict with the midterm/final exam schedule. If the negotiations fail, the Student Society Head(s) should inform the Helpdesk OSA at a minimum Seven (7) days in advance and get prior permission for the participating students to participate in the event from Co-Curricular Activities office, Office of the Dean Student Affairs.

Student Societies

The student societies are the backbone of all the student activities. At LUMS, to nurture a student's talent, beyond the classroom a thriving platform of student societies exists. These dynamic societies, some of which are mentioned below, encourage leadership and professional development in the students.

1. AIESEC at LUMS
2. Alpha
3. Amnesty International
4. Better Educational Engagement Society
5. Animal Welfare Society
6. Data Science Society of LUMS
7. Dance LUMS
8. Debates and Recitation Society of LUMS
9. Dramatic Society of LUMS
10. E-Sports at LUMS
11. Feminist Society of LUMS
12. Finance Society of LUMS
13. Halqa-e-Danish
14. Hum Aahang
15. IEEE LUMS
16. Index Design Society of LUMS
17. Law and Politics Society of LUMS
18. LUMS Adventure Society
19. LUMS Arts Society
20. LUMS Chess Club
21. LUMS Community Service Society
22. LUMS Consultancy Group
23. LUMS Culinary Club
24. LUMS Culture Society
25. LUMS Daily Students
26. LUMS Entrepreneurial Society
27. LUMS Environmental Action Forum
28. LUMS Literary Society
29. LUMS Media Arts Society
30. LUMS Model United Nations Society
31. LUMS Photographic Society
32. LUMS Religious Society
33. LUMS Society of Chemical Science and Engineering
34. LUMS Society of Professional Accountancy

35. LUMS Students Math Society
36. Psychology Society of LUMS
37. Publication at LUMS
38. Radio LUMS
39. Raiyat Urban Planning Society of LUMS
40. ShARE at LUMS
41. Society for the Promotion and Development of Engineering and Sciences
42. SPIE Student Chapter
43. Style at LUMS
44. The Economics Society of LUMS
45. The LUMS Rizq Society
46. The Music Society of LUMS
47. Youth Association for Change and Empowerment

Individual Membership

- All students are eligible to participate in a Society regardless of race, religion, national origin or gender. However, a member needs to understand that the prime objective is to maintain his/her fair academic performance in order to participate in co-curricular / extra-curricular activities.
- Event-specific societies (for example, drama, debates/recitation, sports, etc) are to hold tryouts to select team members. The tryouts are to be of competitive status conducted under a coach/professional with credentials in the affiliated field and overseen by the Patron of the society.
- When society is registered, each and every member shall be registered with Co-curricular Office as well. Individual forms shall be filled and submitted to the Co-curricular Office for the record.

Executive Council Membership

The executive council of a society shall consist of three to five core members in accordance to their constitution. All students are entitled to take part or can serve as an office bearer as per their selection for the respective societies / clubs except for the students on academic probation and the students who have a CGPA below 2.5 in the last completed semester.

Registration of existing society executive council

- After the formation of the executive council, the outgoing council shall register the newly elected council with the Co-curricular Office at the end of the academic year.
- The outgoing council shall be responsible for proper handling over of assets, information, documents and all other matters pertinent to the society to the newly elected council, in the presence of a Co-Curricular Officer.
- In case of no response from the outgoing executive council, the Officer of Co-curricular Office shall carry out a hold to the clearing process of the executive council transmission.

Students on academic probation

The following policy relates to students on academic probation;

- The prime objective of the students on probation is to remain focused on their studies and give secondary preference to co-curricular activities. Students on probation cannot serve as an office bearer or the responsibility in any student organization, club, society or extracurricular activity.

- Students who are currently holding an executive position in a club or society must instantly inform that society and Co-Curricular Officer in case of his proceeding on probation and must quit from his position immediately. Co-curricular Activities office will also review the academic eligibility of officeholders at the end of every semester as soon as individual results are closed out.
- Students who are on probation cannot participate in Co-curricular activities and events which may result in their missing of any graded instruments at LUMS. Students on probation cannot appeal for missing graded instruments at LUMS on account of participation in co-curricular activities.

Students on probation or those with CGPA < 2.5 may be allowed to hold the office bearers position again in the society subject to their regaining of good academic standing.

Disciplinary Committee's Punishments

The student who has an ongoing investigation under his name by the disciplinary committee shall not hold executive positions or office bearer positions. Students punished by the disciplinary committee may take part in the events organized at LUMS. In case of suspension of one or more semesters, such student(s) shall not be eligible to be an office bearer or for participation.

For further details about societies, please visit the following webpages:

<https://osa.lums.edu.pk/student-society>

Contact Information

Area	Contact Person	Contact Information	Ext
Co-Curricular Activities Head & Campus Climate Unit	Hiba Iqbal Zakai	hiba.iqbal@lums.edu.pk	8122
Administrative Manager	Farkhanda Khan	fkhan@lums.edu.pk	8272
Society Activities Advisor & Campus Climate Unit	Ashar Javaid	ashar.javaid@lums.edu.pk	2132
Operations Specialist Intern		cca@lums.edu.pk	
Student Advisor Intern		cca@lums.edu.pk	
Social Media and Communications Intern		cca@lums.edu.pk	

The Counselling and Psychological Service (CAPS)

The Counselling and Psychological Service (CAPS) was founded on the principles which include: “to heal, to care and to educate” the student community at LUMS.

The CAPS team includes a dedicated group of professionals who have chosen to work in a university mental health setting because they know how important it is to support student emotional health and well-being.

The CAPS centre provides free and confidential counselling to all students enrolled in LUMS and strives to “help students help themselves”. The CAPS therapists listen to students in a non-judgmental manner and are committed to helping them explore areas of concern and working on strategies which can assist them.

The therapists at CAPS are aware that taking care of student mental health is a critical skill that will help students navigate their way through life – both as a student and beyond.

At CAPS attending counselling does not mean there is anything wrong with the student; it simply provides a confidential and neutral place for students to freely express their needs and concerns.

Counselling sessions are not registered on the student's academic record. Counselling is simply a place to get some support and assistance that will help the student get through their studies.

Some of the common reasons for students seeking counselling at CAPS include the following:

- Feeling isolated, stressed, or unmotivated
- Adjusting to change
- Feeling overwhelmed
- Managing stress and anxiety
- Handling loneliness or lack of support
- Loss and grief
- Homesick; missing your family and friends
- Concerns with work or study
- Personal development and wellbeing
- Discover and strive toward full potential
- Low mood
- Feeling lost or stuck
- Lack of confidence, self-esteem, or body image
- Coping with a crisis
- Procrastination and study issues
- Balancing commitments
- Dealing with family and relationship issues
- Just needing someone neutral and independent to talk to
- Other

The Head of Department for Counselling and Psychological Services is Dr Tahira Haider and she can be reached at the following email: tahira.haider@lums.edu.pk.

For booking appointments and general queries please contact Practice Supervisor, Rabia Sajjad. _____

Office of Sports, Wellness & Recreation

The Office of Sports, Wellness & Recreation is an integral part of the LUMS community and promoting competitive and intramural sports among the students to create awareness of and encourage physical well-being. The operation and administration of the Syed Maratib Ali Sports Complex and Coca Cola Aquatic Centre fall under the jurisdiction of the Office of Sports, Wellness & Recreation (SWR) at LUMS. The Head of Department for SWR is responsible for the day-to-day operations of the facility. SLUMS, the sports committee of LUMS, consisting of students, faculty, and staff assist the SWR in establishing policies and coordinating the use of sports-related facilities.

Mission

We promote health awareness and also encourage physical well-being by offering a wide range of opportunities for the LUMS community. Significantly, we promote sports culture, intra-mural, regional and

national level intervarsity competitive sports for LUMS students. We aim to provide quality sports facilities and offer a blend of sports opportunities to the entire LUMS community.

Key Services

- Wellness and Wellbeing Programs
- One Credit Sports Courses for Beginners (Fitness, Swimming, Basketball)
- Fitness Training under the world-class infrastructure and qualified fitness instructors
- World Class Swimming Facility for LUMS Community
- World-Class Indoor and Outdoor Sports Facilities
- Locker Facilities for Sports Complex user
- Intra-Mural League Competitions for LUMS community
- Inter-Departmental / School Games
- Sports Facility Reservations for Wellness & Recreational Programs

Key Sports Facilities

1. Coca-Cola Aquatic Centre (Swimming Pool)
2. Executive Gym
3. Separate Gymnasiums for Males and Females
4. Aerobics and Yoga Room
5. 4 Squash Courts
6. 1 Indoor and 1 outdoor Basketball Court
7. 7 Badminton Courts
8. 1 Indoor and 1 outdoor Volleyball Court
9. 2 Tennis Courts
10. Hockey Field
11. Football Field
12. Cricket Field

Lifetime Physical Activity and Wellness Programme

One credit hour sports courses

The cardinal purpose of these sports courses offered is to develop a healthy, active and spirited community at LUMS. Considering the numerous benefits of the programme which would yield, 1 credit hour elective sports courses are offered to undergraduate students. The undergraduate student would be allowed to take 1 sports course per semester during their course of study, and which count towards fulfilling their degree requirement.

Courses offered:

- Strength and Conditioning for Beginners (Male / Female)
- Swimming for Beginners (Male / Female)
- Basketball for Beginners (Male / Female)

Note: These courses are offered only for the beginners so DO NOT opt if you have ever played the game at university /national level. Instructor will assess the individuals at the beginning of the course to evaluate the skills and may ask you to leave the course.

Policy for One Credit Courses

- Each course will be of 28 sessions, 2 sessions per week.
- 80% attendance in the course is compulsory. If the attendance is less than 80% then the participant will not be eligible to take part in final assessment test.
- Students are allowed but not encouraged 4 unexcused absences. Any additional absence will result in failure, from the course. Two unexcused tardy shall constitute one absence.
- In order to accomplish the objectives of this course, participation in class activities and sessions is essential.
- An excused absence on medical grounds must be accompanied by a medical certificate issued by LUMS medical Officer through OSA.
- Each section of Basketball for beginner and Strength Training and Conditioning Courses will consist of maximum 15 students.
- Each section of Swimming for beginner's course will consist of maximum 25 students.
- Elite athletes are not eligible for the courses.
- In case of physical disability or any medical reason, please do not opt the course.
- Participants must be in sports attire during the classes and training sessions as per course requirement.

Rules and Regulations of Usage of the Sports Facilities

➤ **Safety of Users**

The safety of all participants who use the sports facilities is our highest priority. When using the facilities, please consider your own health history, seek counsel from your health provider, and use common sense. In case of an accident or illness, notify an employee at the sports complex reception desk immediately. He / She will assist you to seek help from EMS or LUMS Medical Centre.

➤ **Lost and Found**

The SWR keeps lost items under its custody for a maximum of 24 hours. In case of no claim, the said item is deposited at the LUMS lost and found office (located at the LUMS Security office). The administration of the sports complex is not responsible for lost or stolen items. Lockers are available for students and faculty for day-use.

➤ **User Conduct**

All users are expected to adhere to the policies and procedures approved for the Sports Complex as well as LUMS rules and regulations. Lack of cooperation in adhering to the rules governing the center and its programmed activities will result in administrative action and possible disciplinary action, including removal from the Complex and or cancellation of use/membership privileges.

➤ **Coaching**

The University provides coaches for most sports; please visit the reception desk for details.

➤ **Equipment**

There is a limited quantity of sporting equipment available for users to borrow. These shall not be removed from the premises.

➤ **Clothing**

Members are required to dress appropriate sportswear according to the sport they are playing.

The following are mandatory (except for the swimming pool):

- A sweat / T-shirt must be worn to cover the upper body
- Shorts must be mid-thigh or longer
- Socks must be worn
- Appropriate non-marking footwear is essential

The following are strictly prohibited:

- Casual clothing e.g. front open shirts, jeans, jeans shorts.
- Open-toed shoes, open-backed shoes, sandals, or any types of equipment which can damage the facilities – this determination is to be made by the management.
- The Non-marking shoe allowed only inside the main hall.

Note: Specific sports have additional clothing requirements.

➤ **Disclaimers**

All exercise and sports sessions are undertaken at the member's own risk. Management will not be responsible in cases of injury or accident. Members are advised to get a medical doctor's clearance before starting any serious exercise programme.

All personal belongings brought into the premises shall be kept at the owner's risk.

The University reserves the right to remove individuals from recreation facilities and to revoke membership based on that individual's actions.

➤ **Admittance Policy**

To access the sports complex or the aquatic center a valid University ID is mandatory. Members shall be given access upon submitting a valid University ID at both points of entry. In case the user is unable to show or possess a valid University ID the SWR staff shall be authorized to refuse the entry. No excuse shall be entertained.

Please help maintain a secure environment by using your personal LUMS ID Card upon arrival to gain entrance to the sports facilities, watching your valuables carefully, and notifying the staff if you see something out of the ordinary.

Sports Complex Membership

The membership structure for the sports complex is given below. Proof of University affiliation is required at the time of application.

➤ Faculty/Student/Staff membership

Sports Complex Membership: Full-time students, Faculty (including immediate family) and staff (other than Heads of Departments) will not be charged for membership to the sports complex.

➤ Family Membership

Faculty and staff's immediate family members can use Sports facilities & Gyms from 9:00-17:00 without any charges as per HR policy. Swimming Pool Membership will be as per swimming membership policy.

➤ Swimming Pool Membership

- NO fee is charged from students and staff for membership of the swimming pool.
- Faculty, Administrative Heads of Departments, Assistant Manager and above would be charged for swimming pool membership as mentioned:

Swimming Membership Fee Structure:

Swimming Pool for staff / faculty	Per month
Single Faculty / Administrative Heads / AM and Above staff members	500
Faculty Member & staff with the spouse	1000
Family Membership (including children)	1500
Extended Family Membership (parents of staff/faculty member and children)	3000
For Guest charges for faculty and staff (voucher)	250 per visit

Alumni memberships: LUMS alumni may purchase memberships to the Sports Complex and aquatic center by paying the appropriate fees.

Alumni with Family				
Facilities	Day pass	1 Month	6 Months	1 Year
Alumni Swimming Pool	1000	5000	24000	48000
Alumni Gym/Squash/Tennis etc.	500	3000	15000	24000
Alumni All Facilities	Nil		35000	65000
Alumni Swimming Pool with family		10000	48000	96000

Note: For day pass, alumni will require to make the payment through online portal “sports.lums.edu.pk well in advance. All payment must be made in advance through portal sports.lums.edu.pk.

Exclusive Booking of Sports Complex and Aquatic Centre

Exclusive Booking for 2-hour(s) time per day slot can be booked for any department if they wish to conduct their programme. The charges shall be as follows:

Main Hall booking	Rs. 25,000
Swimming pool charges	Rs. 75,000
Football/Hockey/Cricket	Rs. 25,000

- It should be noted that exclusive booking is subject to availability. The sports facilities are primarily for the usage of the entire community but where possible reservations will be facilitated for recreational Activities for specific programs.
- Day memberships at Rs. 1,000 per day shall be available for the participants of conferences or those on short courses for the usage of all facilities.
- In general, you are advised to book in advance, particularly during peak periods.
- Booking of facilities varies across sports, see relevant rules, regulations and procedures for each sport.
- Children of 12 years and under are allowed at all times but must be accompanied by an adult.

Sports Facility Timings

➤ Sports Complex

Sports Complex can be used from 7:00 till 23:00 night.

➤ Swimming Pool Timings

Time	Monday	Tuesday	Wednesday	Thursday	Friday	Saturday	Sunday
7:00 – 9:00	Male	Female	Male	Female	Male	Female	Male
9:00 – 11:00	Female	Male	Female	Male	Female	Male	Female
11:00 – 13:00	Male	Female	Male	Female	Male	Female	Mixed Family
13:00 – 15:00	Female Faculty/ Staff/ Alumni	Male Faculty/ Staff/ Alumni	Female Faculty/ Staff/ Alumni	Male Faculty/ Staff/ Alumni	Female Faculty/ Staff/ Alumni	Male Faculty/ Staff/ Alumni	Closed for Pool Maintenance
15:00 – 17:00	Male	Female	Male	Female	Male	Female	
17:00 – 19:00	Female	Male	Female	Male	Female	Male	
19:00 – 21:00	Male	Mixed Family	LUMS Team Training	Female	Male	Female	
21:00 – 23:00	Male Faculty/ Staff/ Alumni	Female	Male	Female Faculty/ Staff/ Alumni	Male Faculty/ Staff/ Alumni	Female Faculty/ Staff/ Alumni	

- Children 12 and under are always allowed but must be accompanied by an adult.
- 1 credit hour swimming for beginners' classes are scheduled during the week on given schedules. However, the pool remains available for regular users in the said duration.

Note: The management may close all the facilities or part of the Sports Complex due to repairs, maintenance or expansion of the facility or in case of special events, without notice. Management can re-adjust the operating hours of the facility without any prior notice.

Facility Usage Policy

➤ Operating Hours

Sports Complex will be open from 6:00-23:00 for the LUMS community. However, **all facilities are closed on Government official's holidays**. Essential staff may be deputed on duty subject to the needs of the community by Sports Office.

➤ Swimming Pool Rules

- Pool users will register their names at the reception desk.
- Showers must be used prior to swimming.
- The maximum time for swimming shall be 45 minutes per time slot.
- Pool users must wear swimming suits or swimming trunks upon entry into the pool. Clothing such as cut-offs, gym shorts, and underwear is not permitted as swimwear. Swimwear should not have been worn for exercising immediately prior to pool use and must be colorfast and of lightweight material suitable for swimwear.
- Swimming caps are strongly recommended and mandatory for those with long hair. Using a cap prevents the pool's filters from becoming clogged with hair.
- Avoid swimming if you have skin diseases, open wounds or flu as this may pass the infection to others. Those with skin diseases must provide a certificate from a doctor giving clearance for swimming
- Stay out of the water if you have diarrhea.
- Stay out of the water if you have an open wound (for example, from surgery or a piercing) that is not covered with a waterproof bandage.
- Vaccinations for Tetanus, Hepatitis A and B and Typhoid is highly recommended.
- Children under 12 must be accompanied by an adult 18 years or older.
- Children wearing diapers are not allowed in the pool. Parents are advised that this is a large pool with a minimum depth of 4 feet at both ends and is not suitable for children under 5
- No glass, food, drink, or gum in the pool area.
- Walk at all times. NO RUNNING!
- Excessive horseplay and offensive language/ the behavior of any kind is not allowed.
- Foam or inflatable play apparatus only. (No full-sized flotation devices. Children who need a flotation device must have a parent/guardian within arm's reach)
- Diving from elevation is not permitted. Use lockers provided for other personal items. Lap lanes are for swimming laps only. Skilled swimmers only in deep water. Water guns are not permitted
- Programs such as scheduled training camps and competitions will have priority over drop-in at the pool area. If possible, part of the facility will remain open for drop-in participants.

- The use of the pool is considered a privilege. Those who do not cooperate with established policies, use abusive language, are under the influence of drugs or alcohol or act inappropriately toward a University employee is asked to leave and may have their privileges revoked
- Pool administration will not be responsible for loss due to theft. Secure all valuables in a locker. Locks are available at the equipment desk
- Personal private contract work, i.e., swimming lessons, personal training, and/or fitness workouts of any kind, are not permitted at the Sports Complex
- Anyone interested in receiving private instruction should be referred to the main office for proper registration procedures.

➤ **Table tennis / Badminton Rules**

- Four table tennis tables/badminton courts are available for use.
- Each table is available for the use of a maximum of four players for a time span of 30 minutes.
- After the completion of their stipulated time, the players will leave the table for the next waiting member. The 30 minutes' time limit will start from the time of the first service. No extra time for warm-up is allowed.

➤ **Gym policy (Male & Female) Rules**

- Disrupting or interfering in the workout of other members are not allowed.
- Members should bring their own towels; the Management does not provide them.
- Bags, coats or personal items are not allowed in the gyms.
- Rack users should wipe away sweat left on the apparatus.
- Only gym/fitness instructors are allowed to provide instruction on exercise techniques or equipment preparation and adjustment.
- Gym/fitness room participants should report all malfunctions in equipment, personal injuries and specific concerns immediately to the staff.
- Proper Sports Wear is to be worn in the Sports Area; this includes Tracks Suits, T-Shirts. Jeans, pants with belts, cut-off jeans and shalwar kameez are prohibited in the workout areas.
- All participants are to comply with the gym/fitness instructor's directive regarding enforcement of policies related to safety, programming, exercise techniques, and policies.
- All footwear, except for canvas or sports shoes with rubber soles is prohibited.
- Non-marking athletic shoes are required. Closed-toe athletic shoes and shirts are required in all fitness areas.
- Dropping weights on the floor can cause injury to yourself or others and can also damage the equipment itself. Always set it down as gently as you can
- At the peak time, the maximum time to use the machines is 30 minutes. Always switch off the treadmill after use and wipe off the sweating from the equipment for other users.
- Paper towels are provided for personal and equipment hygiene. Please wipe down equipment after use.
- Keep hands and feet clear of moving parts while the machine is in use. Please use machines and equipment only for their intended purpose.
- Do not operate the equipment if it has loose or damaged parts. If a machine fails to operate correctly, do not attempt to repair it. Notify the gym staff or front desk of the problem immediately so that, they can coordinate for the necessary repair.

- Participants exercise at their own risk, and they are responsible for their own health and safety.
- All free weight users must have at least one spotter. Staff members are not required to spot. Squats done outside the rack require two spotters.
- Return weights to proper storage racks.
- No equipment is to be removed from its designated area except by gym staff.
- Individuals who are not able to safely or properly use the equipment are asked to leave.
- All users must remain at least 5 feet away from mirrored walls during exercise. Please do not touch mirrors.
- Please turn treadmills completely off before getting off.
- Children under the age of 16 are not allowed to go into the weight room or the cardiovascular area
- It is the user's responsibility to follow and obey all rules posted by sports complex staff. Please ask the staff on duty if you have any questions.
- Must clean your sweat after the usage of machines.

➤ **Aerobic Room Rules**

- Equipment provided for different exercises (hand weights, slides, steps, etc.) may not be taken out of the designated aerobic room or area.
- There are class size limitations.

➤ **Sports Complex (Main Hall) Rules**

- Grabbing the basketball ring (hanging on) the rim or nets is prohibited.
- Do not move any equipment set up on the courts.
- Ask the equipment desk for assistance with equipment setup or removal.
- Full-court basketball games are broken into half-court games if participants are waiting to play.
- Use appropriate sportswear and wear non-marking shoes at the basketball court.

➤ **Squash Courts Rules**

- All courts are kept under lock and the key is placed in the front office of the sports complex.
- Squash courts can only be used with the appropriate footwear (Squash Shoes Transparent sole shoes). This footwear must be carried to the court to avoid soiling the wooden surface. Members in incorrect footwear will not be allowed to use the facilities and are barred from using the courts in the future.
- Please adhere strictly to the 40-minute time slot so that court time may be used fairly by all members.
- The start time of the game should be written on the whiteboards placed outside each court.
- Four Squash Courts are available. A maximum of three players can use one court for a time span of 40 minutes. After the completion of their stipulated time, the players will leave the court for the next waiting member.
- The 40 minutes' time limit will start as soon as the members enter the court.
- Members must enter the courts with clean soles he/she must ensure that the sole of the shoe is properly dusted off.
- Do not clean your hands with the back door or glass or walls, please bring your own towel.

➤ **Lawn Tennis Courts Rules**

- Two Tennis Courts are available. A maximum of four players can use one court for a time span of 30 minutes. After the completion of their stipulated time, the players will leave the court for the next waiting members.
- The 30 minutes' time limit will start as soon as the members enter the court to play.
- Members must enter the courts with clean shoes.
- Footwear must be non-marking (transparent rubber sole) rubber-soled / tennis shoes.

Lockers Policy

➤ **Sports Complex Lockers**

Locker storage is provided for users of the sports complex. Users are strongly advised to secure a locker on six month or annual rental basis, to store their personal belongings. You may contact the reception desk for membership. Office of sports, wellness, and Recreation at LUMS is not responsible for any damage, theft or loss of personal items stored in the lockers.

Rental fee for lockers are as follows:

One Year	Rs. 7 per day
Six Months	Rs. 10 per day
Quarter	Rs. 15 per day
One Month	Rs. 20 per day

- Lockers are assigned on a first-come, first-served basis.
- All locker rental transactions take place at the equipment desk.
- Annual and semester lockers are renewable. Lockers not renewed within the two-week period are cleared and the contents stored for 30 days. After 30 days, they are sent to MTSU's Lost and Found.
- The user is charged for any damages to a locker or loss of lock or towel.
- Users should immediately report any damages or loss of these items to the equipment desk.
- Renewals of locker rentals must be paid in full before the last day of the rental, or the locker may be reassigned.
- Children over the age of six years must use the appropriate locker room.
- Only Sports Complex locks are used for overnight storage in the locker rooms. Participants may use personal locks on any day-use lockers in the locker rooms. All locks that do not belong to the Sports Complex are cut off each night after closing.

➤ **Swimming pool lockers**

- Locker keys are provided upon the submission of original University Smart Card and is returned upon returning the locker's keys.
- The Sports Complex staff will remove any personal items left in a locker. Items confiscated may be claimed at the equipment desk. If not claimed within seven days, the items are sent to LUMS Lost and Found.
- The pool lockers are provided for a short period and are free of charge. All pool users shall be eligible to use the locker for 55 minutes maximum. Upon leaving the pool area after the use of the pool he/she shall be bound to empty the lockers and return the keys to the reception desk.

Floodlight Booking

- In accordance with the decision made by the sports committee LUMS, the following procedures are applicable for floodlights:
- Daily on /off timing are from 6:00 p.m. to 12:00 a.m. The operation after midnight must go through a sports committee / sports officer who will request the facilities and engineering department.
- The lights are kept off if no one is playing or practicing. In case any team or group wants to play, the facility is provided. In that case, students are required to inform the Asst. Manager sports or sports staff, who will inform the electric department to switch on the floodlights.
- The floodlight facility shall be available during the competition/matches organized by SLUMS. SLUMS should inform and provide the schedule to related personals beforehand by filling booking forms available at the sports complex reception.
- In accordance with the decision made by the sports committee LUMS, the following procedures are applicable for grounds:
 - The floodlights are provided on a needs basis
 - The representative of the relevant sports/event is responsible to intimate the front desk to switch off the light at the completion of the event.
 - If s/he fails to inform they will not be provided the facility in the future. Sports Office may impose fine to the users in case of violation.

Court Booking

Squash courts (number 3 & 4), Badminton courts and tennis courts are available for advance booking. Members can reserve the courts through e-mail or phone a maximum of two days in advance through swr@lums.edu.pk or extension 3801.

- Bookings are on a first come first serve basis.
- If members do not report within five minutes of their allotted time the booking will automatically be considered canceled
- Members can also book courts in person at the Sports complex reception.
- A valid LUMS Smart Card or Alumni Card is required.
- Booking of courts is available a maximum for two days a week per person.
- Time slots are limited to one per member per day.

Summer Sports Programme

LUMS Sports Office not only facilitating the community but also helping their children grow in their respective physical games. For this purpose, we organized annual summer Sports Academies to promote competitive and intramural sports among the students to create awareness of and encourage physical well-being. This is done by offering a range of fitness and recreational activities to the students belong to faculty, staff, students, alumni and the general public. At the moment, under SWR, LUMS has well-maintained, state of the art sports facilities and highly trained coaches in the following sports:

- Badminton (rubberized coated indoor dual courts with side angle alleviated lights);
- Basketball (rubberized coated indoor dual courts with side angle alleviated lights);
- Cricket (floodlight nets and field with grassy pitches);
- Football (densely grassed field with floodlights);

- Gym Sports/Activities (state of the art gyms with separate rooms for
- Treadmills exercise cycles, stepper, cross trainer, etc.);
- Karate/Taekwondo;
- Rugby (densely grassed field with flood lights);
- Squash (four wooden courts with synthetic front wall and glass back wall);
- Table Tennis (imported tables and partitioned playing space in the main hall);
- Tennis (outdoor courts with rubberized floor and flood lights facility);
- Volleyball (indoor court and outdoor beach courts).

➤ **Scholarships**

Scholarships for Underprivileged students are offered. Application in writing or via email needs to be submitted to the sports office. 50 % discount for LUMS community including Faculty, Staff, Students and Alumni Families.

➤ **Policy for Individual**

- Sports academies are organized during the summer break when the facility is free.
- Age-appropriate instruction are offered in classes such as aerobics, taekwondo, tennis, squash, cricket, football and conditioning.
- Instructional sessions are designed to motivate and develop skills that lead to a lifelong participation
- Participants shall dress in sports clothing and tennis/gym shoes (non-marking soles).
- Participants shall not wear sandals or other open-toed shoes. Each participant shall bring a kit bag carrying a towel, shampoo, comb, deodorant, an extra shirt, socks, and their own mineral water bottle daily.
- A refreshment stand is arranged during the training programme. Participants can avail juices on-demand at concessional rates
- Participants shall not wear jewelry. University and its employees shall not be responsible for any items that are lost or stolen during the sports training.
- A child may not leave with anyone other than the person(s) authorized on the registration form.
- The child is handed over to the authorized person carrying the security card issued by LUMS SWR Department.
- Parents admitting more than one child may be given a discount on the fee upon tendering a formal application to SWR Office. Approval of said discount is subject to the condition
- A child may not leave the programme early unless written notice is received from the parent/guardian
- SWR reserves the right to revoke the registration of any child who consistently disrupts normal activities. While this is a rare occurrence, it is important to note that consistent disruptions diminish the experience of the other participants. No refund shall be made if a child is dismissed from the programme. Children missing the programme for reasons other than medical will not be allowed to make up missed sessions. Split sessions are not available.
- Families of alumni, students, faculties and staff children shall be given first preference for participation.
- The participants are required to deposit the charges into MCB LUMS Booth or T Block branch and submit the deposit slip along with filed registration form at the reception desk.

First Aid Disclaimers

- First aid and emergency medical services are available in the sports complex by student volunteers subject to their availability on campus.
- A doctor is also available at LUMS Medical Centre Near to Super Store 24/7.
- All exercise and sports sessions are undertaken at the member's own risk. Management will not be responsible in cases of injury or accident.
- Members are advised to get a medical doctor's clearance before starting any serious exercise programme
- All personal belongings brought into the premises shall be kept at the owner's risk
- All Students representing LUMS outside of campus needs to submit disclaimers signed by each individual to the Sports office prior to the departure.

Students Participation in International / National Sports Competitions

LUMS Encouraging its students to participate in World Universities Sports Leagues, Higher Education Commission, Higher Education Departmental games. Only those players are eligible to represent LUMS who attend training/practice sessions conducted by SWR coaches and selected during annual trails held by Sports Office. Moreover, LUMS Students can only participate in any Sports -related competitions after the necessary approval from Office of Sports, Wellness and Recreation. Sports at LUMS (SLUMS) nominations can be rejected in case players are not as per playing standards of game rules. Any form of supplements/muscle enhancement medicines are prohibited for players.

➤ **Sports Competitions Participation**

- All events participations will be approved by Head of Sports, Wellness & Recreation at least 7 days prior to the competition subject to the availability of facility / required resources
- Sports Officials will accompany the teams at outstation competitions
- One disclaimer will be submitted to relevant game coach or Sports office at the time of trails
- One Disclaimers will be submitted to Sports Office at least 3 days prior to the departure for every competition separately
- LUMS will follow the international playing rules for competitions at LUMS. However, for competitions at other universities, HEC, HED, International and National Levels, hosts rules will be applicable to disqualify the player
- Players need to submit original educational documents to Sports Office for necessary verification if needed by HEC, HED or any other tournament organizers
- Participation in Sports Competitions is voluntary and honor for students so no player can seek any favors from LUMS administration on account of his / her participation in Sports Competitions.

➤ **Petitions for Sports Players**

Petitions will be forwarded to OSA for only the approved list of players for the specific dates and classes after necessary documentation. Late submission at students' end will not be acceptable. OSA will be the final authority to approve or reject the petitions based on the recommendation of the Sports Office.

Contact Details:

Name	Designation	Contact Information	Ext
Babar Asad Khan	Head of Department	asadk@lums.edu.pk	8165
Ateeq ur Rehman	Senior Sports Officer	ateeq_rehman@lums.edu.pk	8534
Muhammad Zahid Arif	Sports Officer	zahid.arif@lums.edu.pk	3807
Amir Hussain	Pool Administrator	amir.hussain@lums.edu.pk	3811
Sports Complex Reception	Receptionists	swr@lums.edu.pk	3801
Swimming Pool	Staff on Duty	swr@lums.edu.pk	3811

OFFICE OF FINANCE

The Finance Department handles all financial matters related to the Students along with University's Account Receivables, Accounts payables, Taxation, Treasury, Financial Reporting, Budgeting and Planning.

Accounts Receivable specifically deals with financial matters pertaining to the students' fee/hostel/charges/final settlements, student loans and maintaining of student's individual accounts etc.

Key Services

Finance Department is responsible for:

- Collection of tuition and on-campus residence charges
- Issuance of Vouchers
- Payment of refunds
- Handling general fees and payment inquiries
- Student account clearance upon graduation/withdrawal and refund of security
- Issuance of Advance Tax certificates
- NOP/ PhD Stipend payments
- Taking care of financials related to student clubs and societies.

Fee Structure

- Tuition Fee at LUMS for First Year students & Sophomores is based on the number of credit hours taken in a semester. However the tuition fee for Junior, Senior and Super Senior is same as last year based on 12-20 credit hours fee policy.
- Students are responsible for buying their own books and other reading material.
- For all undergraduate programmes at LUMS, a student is required to take at least 12 credit hours per semester to acquire full-time status.
- However, the credit hours requirements in first year varies amongst undergraduate programmes due to its specific design, therefore the tuition fee amount also varies according to number of credit hours requirements in each programme. The first year students' programme-wise fulltime credit hours requirements are as follows:
 - SBASSE first year students required to enroll in minimum 18 credit hours in Fall and 16 credit hours in Spring semesters respectively.

- SDSB first year students are required to enroll in minimum 16 credit hours in Fall and 17 credit hours in Spring semesters respectively.
- MGSBSS and SAHSOL first year students are required to enroll in minimum 16 credit hours each in Fall and Spring semesters respectively.

The School wise detail of Tuition fees for regular semester for the year 2020-21 for first Year students is as follows:

Fee for Undergraduate Programs - FY 2020-21

The fee estimates for 2020-21 has already been shared with the students at the time of admission through fee information document. Though LUMS has already finalized the Fall Semester Fee but due to COVID, LUMS is reassessing the situation and will finalize the Spring Semester fee later.

Financial Aid assessments for Spring Semester (if any) will also be revised accordingly. In case of further fee related queries, kindly contact at helpdesk@lums.edu.pk.

Fees for Sophomores/Junior/Seniors – FY 2020-21

The Fall Semester Fee for 2020 will be shared with you through an email from Finance Department. Though LUMS has already finalized the Fall Semester Fee but due to COVID, LUMS is reassessing the situation and will finalize the Spring Semester fee later.

Financial Aid assessments for Spring Semester (if any) will also be revised accordingly. In case of further fee related queries, kindly contact at helpdesk@lums.edu.pk.

Advance Tax

Through an amendment in the Income Tax Ordinance 2001 by Finance Act 2020, advance tax (under section 236 I) shall be collected @5% on the entire amount of fee (if students fee payer is not appearing on the active taxpayers list and payable exceeds Rs. 200,000/- per annum, excluding the amount refund).

Tax certificates can be downloaded through below appended procedure.

1. Log into your Zambeel account
2. Click on the Tile/Icon named “**Self Service**”. (System will navigate you to the self-service page)
3. On the left side of the page, click on the “**Taxpayer Service**”. (System will navigate you to the Tax Payer Service page).
4. Hyperlink(s) for downloading Tax Certificate will be available under your name.
5. Click on the hyperlink and download your Tax Certificate.

Payment Deadline

Fall Semester : 07th September, 2020 (Returning Students)
Spring Semester : December 24, 2020

All paid fee vouchers (student copy) should be kept by students during their stay at LUMS.

Terms and Conditions

- Applicants must pay fee within deadline as stipulated in the fee voucher.

- Fee can be paid at any branch of designated Banks as mentioned in the fee voucher through bank draft, pay order or cash, however, students can also pay fees online through credit cards by visiting <http://pay.lums.edu.pk>
- Fees for Transfer and Visiting students are charged according to standard per credit hour rate.
- Auditing students are charged according to standard per credit hour rate and if returning students wish to audit a course beyond his/her maximum permissible semester quota of 20 credit hours, then he/she must pay 20% of the tuition fee for each extra credit hour.
- Once registered, students can access their account online through Zambeel for inquiry of their account balances.
- University fee is usually announced once every year; however, tuition fee is subject to change without prior notice.
- In case of non-payment of dues within the deadline, the provisional semester course enrollment will be wiped out. After the wipe-out process, students who pay the University dues may have their enrollment reinstated provided there are spaces remaining in the required courses. Students who fail to pay the dues after wipe-out will not be eligible to attend the ongoing semester

Finance department will send an email to students for reminding Fee and related important timelines before start of each semester, which includes:

- Tuition and Hostel Fee voucher generation date.
- Voucher payment deadline.
- Wipe out date (from enrolled courses due to non-payment).
- Fees refund deadlines.
-

Fee Refund Policy – FY 2020-21

Admission Cancellation

- Applicants who do not meet the condition(s) stipulated in the offer letter shall be entitled to get tuition fee, lab charges, semester registration, hostel fee and admission security refund.
- **Only 50% of admission fee is refundable to account for expenses already incurred by the university.**
- **Advance tax cannot be refunded** and is deposited in Government treasury on collection. Tax deduction certificates will be provided.

Separation / Suspension

- If a student is separated / suspended from the programme by the University for academic reasons, and has deposited the dues for the next semester, all such dues deposited will be refunded.
- If a student is separated / suspended from the programme due to disciplinary reasons or reasons other than academic, the dues deposited by him/her for the current semester will not be refunded. However, if for some reason, the decision is delayed till the next semester and the student pays the dues for the next semester, such dues will be refunded.

Withdrawal from the Programme

- In case a student finds it necessary to withdraw from the Programme before the commencement of classes, he/she must inform LUMS Office of Admissions (admissions@lums.edu.pk) in writing.

- In case a current student wishes to withdraw from the Programme after the commencement of classes, he/she must inform Registrar’s Office (ro@lums.edu.pk) in writing. Upon approval the following refund policy will apply:

Fee Component	Deadline	Amount of Fee Refund
Admission Fee		Non Refundable
Admission Security	Fully Refundable	100%
Tuition Fee, Lab Charges, Semester Registration (Fall / Spring Semester)	Before the commencement of classes	100%
	Up to first seven (7) days of the commencement of classes	100%
	From eight (8) – fifteen (15) days after the commencement of classes	50%
	More than fifteen (15) days after the commencement of classes	Non Refundable
Summer Semester Fee		Non Refundable
Advance Tax	Collected under section 236(l) of the Income Tax Ordinance 2001	Non Refundable
Hostel Fee	Before first day of the commencement of classes	100%
	After first day of the commencement of classes	Non Refundable

- First Year students cannot take their First Semester off or drop/withdraw from all courses.
- The University reserves the right to change its policies and fee structure at any time.
- Amount will be refunded within two weeks on receipt of refund application along with all required documents.
- In case of any query regarding fee; please contact at helpdeskar@lums.edu.pk

Online Clearance

Students who withdraw or separate from LUMS at any time during the year will apply for online clearance using Zambeel self-service. Upon successful online clearance from all respective departments the student is entitled to get his/her final settlement done from LUMS.

At the time of graduation, while submitting form for online clearance, students are given option either to take refund of their securities/excess balances OR donate that amount to LUMS.

For refund, student needs to provide the following information to Finance Department:

- Account Title
- Complete IBAN #
- Bank Name
- Scan copy of Beneficiary’s CNIC

On-Campus Residence

Following are the hostel charges estimates for on-campus residence:

Particulars	Amount in Rs.
On-campus residence charges – triple occupancy (per semester)	30,000
On-campus residence charges – double occupancy (per semester)	45,000
On-campus residence charges – triple occupancy (Summer semester)	6,000
On-campus residence charges – double occupancy (Summer semester)	9,000

Terms and Conditions:

- The fee paid for On-Campus Residence is non-refundable (after commencement of classes).
- On-campus residence charges must be paid within deadline as stipulated in the voucher.
- **By making the payment, applicants are deemed to accept the terms and conditions of on-campus residence charges and refund policy as mentioned above.**
- In-house residence facility during Summer Semester is also available and a separate fee is charged.
- For specific residence queries, kindly contact residence team at residence@lums.edu.pk

Contact Information:

Finance Department, Allied Bank Hostel (M-7) basement, LUMS, Tel: +92 423 5608000

Area	Contact Person	Contact Information	Ext.
Student Fee Queries	Madiha Jaffri / Ehtesham Umer / Nida Azhar	helpdeskar@lums.edu.pk	4406/8151/4435
TA Payments	Muhammad Shoaib	Muhammad.shoaib@lums.edu.pk	4440
Student Refund cheques collection	M. Jahangir Mughal	Muhammad.mughal@lums.edu.pk	8342
Advance Tax Certificate Collection	Ahsan Tanveer/Mansoor Liaqat	ahsan.tanveer@lums.edu.pk mansoor.liqat@lums.edu.pk	4448/8296
Student Taxpayer Information	Ahsan Tanveer	infotax@lums.edu.pk	4448
Student Societies Related Queries	Usama Tahir	usama.tahir@lums.edu.pk	4429

OFFICE OF ADVANCEMENT

The Office of Advancement integrates the operations of Marketing, Communications, Alumni Relations and Development and works towards a unified mission, which is ‘To communicate a compelling narrative, strengthen relationships with key internal and external stakeholders of LUMS, and facilitate sustainable growth for the University’.

Communications

The Communications department is committed to sharing the LUMS story that informs, inspires and engages audiences. As a strategic partner to the University, the team works collaboratively with multiple partners, to curate and shape messages into stories and experiences that elevate the University’s reputation and maintain its unique identity. The department reaches out to the LUMS leadership, students, faculty, staff, prospective students, donors, visitors and alumni to foster active engagement with the University and build a concrete relationship with each of them. As the official voice of LUMS, the team liaises between these groups and identifies the appropriate style, tone, messaging, strategies, and platforms to best highlight the University’s global impact.

The team works collaboratively with campus partners to provide a number of targeted communication services, both print and digital. The department also ensures that all internal and external communication – from standees and posters to official correspondence, reports and brochures – are consistent in terms of approach and messaging. Annual publications such as the Academic Report, Profile Book and others are also developed by the department, in addition to a fortnightly e-newsletter that is circulated to internal and external stakeholders and covers the latest happenings at the University.

For more information or in case of any queries, feel free to contact us at communications@lums.edu.pk

Marketing and Branding

Recognised internationally as an institution for higher learning, LUMS is committed to providing world-class education to bright and talented students from across the world. Every year, the Marketing team leads several efforts across multiple platforms to elevate the University's profile nationally and internationally.

True to LUMS philosophy, the Marketing department works collaboratively to identify most effective platforms to tell the best "stories" about LUMS' excellence, whether through news, media outreach, print, web, social media or other digital strategies. As custodians of LUMS brand, the marketing team also designs and executes different campaigns that elevate the brand, engage multiple audiences and showcase the University's impact in society and the industry. The department also provides stakeholders with a variety of targeted marketing and digital solutions.

The focus of the unit is to build awareness, manage perceptions and increase support for LUMS across the board. This is achieved by collaborating with partners across the campus to connect LUMS with target audience segments as well as the community at large. Marketing works on highlighting the achievements of LUMS and its family – students, alumni, faculty and staff through the website and social media presence on Facebook, Twitter, LinkedIn, Instagram, Snapchat and YouTube.

The unit is also responsible for marketing programmes offered by the five Schools at LUMS, providing prospective students and the general public with essential information about the different programmes and helping them with the admission process. Various marketing activities are carried out throughout the year, such as nationwide school outreach, information sessions at educational institutes, expos for potential students and their parents, open days in various cities, programme webcasts and ATL, BTL and TTL campaigns for the programme admissions.

Alumni Relations

Our mission is to ensure sustainable and meaningful engagement* with our alumni. We aim to continuously establish new ways of connecting, which will better meet the needs of alumni, students and the University. We truly are in the business of friend making, with an overarching vision of establishing two-way communication with alumni leading to a mutual give and take.

**Engaging our alumni involves fostering a relationship with this ever-growing community that embodies the LUMS spirit, strengthening their connection with their alma mater, including them in the University's countless initiatives, and providing them with opportunities that help enhance both their professional and personal lives.*

To facilitate networking, we have formed alumni chapters in various cities and countries all over the world. In addition to providing a forum for socialising, these chapters are a source of great support for newcomers

to the area. They also help LUMS with its marketing, placement and fundraising efforts. In an effort to facilitate even closer networks amongst our alumni, we have also formed affinity-based alumni associations such as the SDSB Luminites Association, the CSS Alumni Association, the Law Alumni Association, and the CS Alumni Association and we look towards creating more in the future.

Our communication with the alumni community includes the alumni website, the annual alumni magazine, alumni social media pages and a quarterly alumni e-newsletter. Through these channels, alumni and students can get the latest information on LUMS, job openings, alumni benefits, corporate discount offers, faculty research, alumni success stories, activities of LUMS alumni chapters, and general news and announcements. A major part of our engagement with alumni focuses on reunions and events. Batches and chapters get together for different kinds of reunions throughout the year from batch teas and mentorship workshops, to guest speaker sessions and class reunions. In addition, the flagship event of the year for our alumni community is the annual Alumni Homecoming where alumni are welcomed back to campus for all kinds of knowledge sharing and merriment.

Alumni can also avail a variety of privileges offered through the LUMS Alumni 'Smart' Card. These include LUMS car stickers, discounted accommodation at REDC, access to LUMS sports and library facilities, and a range of corporate discount offers. Alumni Relations offers a programme of events and activities to help students make the most of our global network of more than 14,000+ alumni (graduates). We generate opportunities for alumni, friends and supporters to stay involved with the University.

For more information or in case of any queries, feel free to contact us at alumnirelations@lums.edu.pk

Development

Development aims to create and foster relations between LUMS and donors through various activities that engage, acknowledge and recognise the latter. Development consists of two portfolios: donor outreach and donor stewardship. The donor outreach team maximises the grants received for the National Outreach Programme, student scholarships, infrastructure and research. Whereas, stewardship works towards building and maintaining productive relationships with donors and creating a mutually beneficial relationship.

Funds are solicited from donors that include international agencies, public sector organisations, corporates, high net-worth individuals and our alumni. Through the efforts of the Development team, generous scholarships are offered to students every year through the National Outreach Programme and Financial Aid. Currently, 35% of our students are receiving some sort of scholarship, ranging from 20 -130% of tuition. Donors are kept well-informed about the progress of sponsored students.

Renowned for academic excellence, LUMS is also a leader in sponsored research projects. To support research, our team is working towards partnership opportunities with various corporates through setting up named endowed chairs. Development also facilitates naming opportunities for infrastructure within LUMS.

For more information or in case of any queries, feel free to contact us at giving@lums.edu.pk

LUMS LEARNING INSTITUTE (LLI)

The LUMS Learning Institute (LLI) was established in 2019 as a state-of-the-art centre for teaching and learning. Inspired by successful models from universities around the world, the Institute engages students

as partners in educational development, supports faculty with instructional skill development and critical inquiry on the impact of their teaching on student learning, and promotes an environment for sustained effort and shared responsibility for quality enhancement.

Mandate

The LLI's core mandate is to strengthen teaching and learning communities, cultures and practices at LUMS university. The LLI provides leadership in teaching and learning by encouraging and supporting the scholarly exploration, innovation, implementation, evaluation and dissemination of teaching and learning practices. LLI's focus is on four key areas:

1. Supporting evidence-based pedagogical practice
2. Purposeful collaboration with students
3. Strategic growth and enrichment in both the human and technological resources supporting excellence in teaching and learning at the university and beyond
4. Innovative pedagogical research that enhances and responds to teaching and learning practices

Core Programmes

The LLI core programmes are co-lead by LUMS faculty, LLI staff and student partners.

The Institute engages students, individual faculty and departments in conversations and collaborations on teaching and learning through four inter-connected programmes.

1. Faculty Development

The faculty development programme currently has 3 main focus areas. To date, the 3-day Instructional Skills Training (IST) workshop is one of the most popular teaching development opportunities at the LI. In the IST, participants work in small groups to learn how to implement lesson design and increase student engagement in learning. Each day they design and deliver three 10-minute lessons and receive verbal, written and video feedback from their peers and trained facilitators. In 2019-2020, 65 faculty and PhD students participated in the IST. Six facilitators were also trained through the LLI in an effort to develop local capacity at LUMS to sustain the IST workshops

The blended Teaching Experimentation course provides an extended opportunity for teachers to practice and develop their lesson design and instructional skills in courses currently in session. Teachers use a combination of video and online annotation tools to offer feedback to peers on their lessons.

The 2-day course design seminar offers teachers the opportunity to design or redesign courses. Teachers work on developing course syllabi, attend short workshop sessions, and receive feedback from peers in small groups. The session is offered twice a year in face-to-face and blended formats.

2. Student and Faculty Pedagogical Partnership Programme

The student-faculty pedagogical partnership programme aims to introduce new opportunities for students and faculty to work in partnership on pedagogical initiatives, while also supporting existing partnerships across LUMS. The goal is to support teaching, learning and research excellence with students as collaborators and active contributors. Partnership programmes are well-embedded in several international universities and have been found to be extremely beneficial for both faculty and students in enriching their teaching/learning experiences. As the programme continues to develop at

LUMS, we aspire to engage and work with several groups of faculty/student partners and offer grant funding to support their work. Students and faculty will have opportunities to submit proposals for funding for pedagogical projects in the near future.

3. LUMSx

LUMSx is a university-wide initiative to enable faculty to create online and blended learning experiences which will transform teaching and learning at the LUMS, and beyond. This programme offers instructional design, pedagogical and technological support to faculty in order to assist them in their technology-driven learning initiatives. Additionally, LUMSx aims at improving teaching and learning via online platforms by enabling faculty to conduct research through experimental design and longitudinal studies on online pedagogies and students' learning behavior in online settings. As a strategic initiative, LUMSx is also working closely with the Rausing Executive Development Centre and the Centre for Continuing Education to transform executive education as well as contribute to lifelong learning.

4. Research in Teaching and Learning

LLI leads and collaborates on research that informs our work in supporting evidence-based pedagogy, contributes to institutional teaching and learning priorities, and develops new knowledge about teaching and learning. We aim to support and recognize teaching and learning research through future programming and by creating opportunities for scholarly discussion, dissemination, and recognition.

Contact Information:

Designation	Name	Email ID
Director	Dr. Suleman Shahid	suleman.shahid@lums.edu.pk
Associate Director	Dr. Launa Gauthier	launa.gauthier@lums.edu.pk
Associate Programme Manager	Mashail Imran	mashail.imran@lums.edu.pk
Faculty Development Lead	Dr. Yasira Waqar	yasira.waqar@lums.edu.pk
Pedagogical Partnerships Lead	Dr. Tayyaba Tamim	tayyaba.tamim@lums.edu.pk

CENTRE FOR CONTINUING EDUCATION STUDIES (CES)

The Centre for Continuing Education Studies (CES) at LUMS is dedicated to extending educational opportunities to diverse learning communities in Pakistan. Our programmes, designed and delivered by highly acclaimed industry experts and academics, are tailored to the needs and expectations of learners from various walks of life.

Through an extensive range of courses, offered in a variety of fields and formats, CES seeks to support students, professionals and non-traditional learners to pursue their newly found interests, rediscover old passions, develop professional expertise, or simply expand their intellectual horizons. The Centre for Continuing Education Studies (CES) offers courses of flexible durations ranging from weekend-long workshops and short courses in the evenings to semester-long programmes. These courses are taught by leading LUMS faculty and industry professionals. We have thousands of student enrolments each year from all over the country. Many courses are open to all and don't need any pre-requisites to apply.

Our courses are mostly geared towards individuals who are not necessarily looking to enroll in a degree programme but are curious about a new subject or want to pursue their lifelong passions and develop their skillset in a particular subject area.

The Centre's new approach includes concerted efforts to develop innovative and diverse curricula, offer certifications and diplomas, and pioneer courses on new formats.

Committed to enhance and expand the learning opportunities offered by CES, we aim to contextualize the role of the centre in identifying learning communities beyond LUMS and addressing their learning needs and expectations.

CES Vision

- Continuing/part-time/professional education
- Reaching out to diverse learning communities
- Curriculum development

Statistics

Since its inception in April 2017, 4000+ participants have successfully graduated and have become a part of our alumni network.

- Employees of top MNCs and leading national firms have been trained by us.
- These include PepsiCo, Coca Cola, Unilever, Levi's, TOTAL Parco, British Council, WWF – Pakistan, Federal Board of Revenue (FBR), Packages, Nishat Group, FINCA, Systems Limited, Allied Bank Limited, DESCON, Honda Atlas, Zameen.com, Indus News, SUFI Group, Amal Academy, Finca.
- Over 60 courses offered
- Participants ranging from the ages of 14 – 72.

For more information or in case of any queries, feel free to contact us at ces@lums.edu.pk

THE GAD AND BIRGIT RAUSING LIBRARY

The Gad & Birgit Rausing Library at Lahore University of Management Sciences serves as a centre for information resources and knowledge for the faculty, researchers and students through its wide range of collections, competent staff, high quality infrastructure, and innovative services. Currently the library has a collection of over 276,000 books and documents, access to 180,000 online books, 2500 Audio Visuals, CDs & DVDs, and subscription to 350 print journals. It also provides campus-wide as well as off campus access to over 35,000 full-text online research journals published between the 1800s to the present. The library maintains press clippings from leading national newspapers on 51 broad subject areas related to Pakistan's business and economy. It also indexes more than 25 major Pakistani business & social science periodicals in the Pakistan Periodicals Index database. In line with the library's mission to excel in supporting the academic and scholarly endeavours of its users' core instructional and research requirements, the library continuously strives to introduce user-focused innovative systems, services and resources.

Library Services

The library offers a variety of services to assist the faculty in their teaching and research. These include but are not limited to:

- **Course Guides:** The Library has developed these guides on core subject areas using state of the art content management system, LibGuides. This service enables library users to find their required contents on specific subject areas through a customized interface. Guides on all subject areas and their relevant courses have been developed and are regularly updated by the relevant library staff.
- **NaviBook Application:** The NaviBook, a navigator application kiosk is the first-ever facility introduced by Gad & Birgit Rausing Library in Pakistan, it facilitates the visitors to search and navigate through 150,000 books available in more than 1000 racks housed on two floors of the library. The navigation path to the desired book rack can also be imported to NaviBook Android through QR code.
- **Self-Check Service:** Self-check kiosk enables users to checkout/ check-in and to renew library material without any intervention of the library staff. This service saves the time and efforts of the users.
- **Digital Scanning Service:** Two digital scanners are available on both floors of the library. Users can digitize their required contents (within copyright limits). This service is environment friendly and saves time and paper.
- **Kindle e-readers Issuance:** Kindle e-book readers have been made available for issuance (for Fourteen days). Kindles are pre-loaded with classics, fiction and course packs, and these readers are also configured to access more than 35,000 online journals and over 150,000 e-books.
- **Book and Article Alerts:** Alerts are sent to the concerned faculty according to their interest areas determined by the librarians during library orientation, and through the circulation of the list of subscribed journals. Lists of fresh arrivals are circulated to users and posted on the library portal at <https://library.lums.edu.pk/book-list>
- **Document Delivery Service:** If an article or a document is not available in the library, arrangements are made to acquire it from other libraries through interlibrary loan and international document delivery services.
- **Virtual Private Network (VPN):** It provides off-campus access to library's full-text resources at: <https://vpn.lums.edu.pk/+CSCOE+/logon.html>
- **Teaching Resource Centre:** Teaching Resource and Circulation librarian (mnadeem@lums.edu.pk) helps in getting instructor manuals, tutorials, PowerPoint presentations, test banks, course outlines of other universities, student handouts, and solution manuals.
- **Reference and Research Support Services:** Specialized helpdesks have been set up to provide in-depth reference and research support. Users can visit these helpdesks, seek assistance through telephone, fax, and e-mail, and can also live chat with library professionals through the web chat facility at <https://library.lums.edu.pk/live-chat-library>. The Library also facilitates its users in searching for relevant literature to support their academic and research endeavors.
- **SMS alerts:** Library has initiated SMS alert service for its users. Now the users receive SMS alerts from LUMS Library two days before due date of issued items.
- **Plagiarism Detection Support:** The Library facilitates LUMS faculty's access to online plagiarism detection service Turnitin. It provides training to use this tool and helps faculty member with interpreting similarity reports of the publications scanned through Turnitin. Mr. Waris Ali Arslan (waris.arslan@lums.edu.pk) can be contacted for any assistance in this regard.

- **Multimedia Services:** The Library provides access to audio-visual material including DVDs, CD-ROMs, and videos, which can be borrowed or watched in-house. The services section is equipped with Cable TV, VCR, and CD/ DVD players.
- **Wireless LAN:** The Library is a Wi-Fi enabled area that provides Internet connectivity to its fast-growing smart phones, notebook, and laptop users.
- **Video Lecture Server:** It is used to provide access to video lectures, research documentaries, academic events, convocation and graduate night videos etc. These videos can be accessed at <http://panopto.lums.edu.pk/Panopto/Pages/Default.aspx> The IST department has a video recording facility for faculty and visiting dignitaries.
- **Donating Books:** The library has initiated the campaign “Love your books, then share them” between the LUMS community to spare the knowledge. A donation shelf has been placed near the newsletter section. There are some terms and condition to accept the donation; donated books should be in good condition, do not accept dirty, yellowing or have torn — loose or missing pages.

Organization of Collections

The Library is spread over two floors. The ground floor houses collections on Business, Computer Science, Pure Sciences and Engineering, as well as, popular books and magazines, theses and dissertations, graduate students’ projects, multimedia, course reserves, photocopiers, self-check machines, e-kiosk, digital scanner, digital access center, finishing corners, bookshop, and circulation counter. The first floor (Khalid Ishaque Wing) houses books on Economics, Humanities and Social sciences, Law, Politics, History, Languages and Literature, Rare books and the Oriental collection. It also has scholar's common, researcher’s common, digital scanner, photocopier, finishing corner and coffee reading lounge, where hot beverages are allowed. The books and other reading materials are put into various sections according to the specific nature of the collection. The library uses the Dewey Decimal Classification Scheme to classify and shelve its knowledge resources. It starts from 000 and goes to 999 in decimal order.

Electronic Resources

The Library’s electronic resources are growing at a fast pace. It provides access to a wide range of electronic resources including e-databases, e-journals and e-books that are accessible on campus and off campus through VPN. Some important resources are:

- **SCOPUS** - <http://www.scopus.com/>: Scopus is the largest abstract and citation database of peer-reviewed research literature with over 20,500 titles from more than 5,000 international publishers. Scopus offers researchers a quick, easy and comprehensive resource to support their research needs in the scientific, technical, medical, and social sciences fields, as well as arts and humanities.
- **Grammarly**- <https://www.grammarly.com/signup>: Grammarly is an automated tool that corrects contextual spelling mistakes, checks for more than 250 common grammar errors, enhances vocabulary usage and provides citation suggestions. Grammarly will not edit your work for you; it is up to you to incorporate Grammarly’s feedback and decide what suggestions are most appropriate. Grammarly can be used through web interface as well an add-in for MS Word can be download from <https://www.grammarly.com/office-addin>
- **Science Direct** -<http://www.sciencedirect.com>: it is the world's leading electronic collection of journals and provides access to the full text of the last ten years. Subject areas include business, management, mathematics, computer science, and economics

- **Wiley Interscience** - <http://onlinelibrary.wiley.com>: It has over 1400 leading journals. It covers full spectrum of science, technology, engineering, medicine, business, social sciences, and humanities.
- **SpringerLink** - <http://www.springerlink.com>: It is one of the world's leading online information services database for scientific, technical, and medical books and journals. Over 1100 peer-reviewed journals are available with back files starting from different ranging dates.
- **Business Source Premier** - <http://search.ebscohost.com>: Business Source Premier is the most popular business research database that features the full text of more than 2,150 journals. The full text is provided for journals published since 1886, and searchable cited references date back to 1998. Additional full text, non-journal content includes market research reports, industry reports, country reports, company profiles, and SWOT analyses.
- **Cambridge Journals Online** - <http://journals.cambridge.org>: It is the Cambridge University Press' collection of nearly 200 leading journals across the sciences, social sciences and humanities.
- **Emerald Insight** - <http://www.emeraldinsight.com>: Emerald Insight provides full text of all 150+ Emerald online journals available, with full text back-files, many going back to 1990's, with abstracts going back in some cases to 1980's.
- **Informa Journals** - <http://journals.informaworld.com>: It has 12 scholarly journals including the flagship journals Operations Research and Management Science. It provides full text access to current four years' content.
- **IEEEExplore** - <http://ieeexplore.ieee.org>: IEEEExplore provides full-text access to 132 IEEE and 45 IEE journals, magazines, transactions and conference proceedings as well as active IEEE standards.
- **ACM Digital Library** - <http://portal.acm.org>: ACM digital library includes full-text articles from all ACM journals and magazines – from 1985 to the current issues, and ACM conference proceedings for the same period.
- **American Chemical Society (ACS)** - <http://pubs.acs.org>: It provides full text access to more than 40 ACS journal titles, some of which date as far back as the 1800s.
- **JSTOR** - <http://www.jstor.org>: It is an online archive database with complete back files of over 1100 journals covering business, economics, mathematics, law, humanities, social sciences, and education.
- **LEXISNEXIS Academic** - <http://www.lexisnexis.com/hottopics/lnacademic/> It provides access to more than 3.5 billion public records including state and federal case law; codes and statutes; court documents and extensive secondary materials.
- **Questia Digital Library** - <http://www.questia.com>: This online library that provides 24/7 access to the world's largest online collection of over 67,000 books, and 375,000 journal articles in the humanities and social sciences.
- **ProQuest Dissertations and Theses**: ProQuest Dissertations and Theses (PQDT) is an online database that indexes, abstracts, and provides full-text access to dissertations and theses. It is a world's most comprehensive collection of dissertations and theses from around the world. This database includes over 2.4 million records and covers 1637 to the present.
- **ProQuest e-books Central**: It offers an increasing selection of more than 180,000 e-books in business, economics, computers, engineering and technology.
- **Oxford English Dictionary**- <http://www.oed.com/>: The Oxford English Dictionary is the accepted authority on the evolution of the English language over the last millennium. It is a guide to the meaning, history, and pronunciation of over half a million words, both present, and past. It traces the usage of words through 2.5 million quotations from a wide range of international English

language sources. The OED covers words from across the English-speaking world. It also offers etymological analysis and listings of variant spellings.

- **World Bank Global Development Finance (GDF Online):** GDF (online) contains statistical data for the 138 countries that report public and publicly-guaranteed debt to the World Bank Debtor Reporting System. The database covers external debt stocks and flows, major economic aggregates, and key debt ratios as well as average terms of new commitments, currency composition of long-term debt, debt restructuring, and scheduled debt service projections.
- **IMF E-Library:** The International Monetary Fund's (IMF) e-Library simplifies analysis and research with direct access to the IMF's periodicals, books, working papers and studies, and data and statistical tools. It provides information and perspective on macroeconomics, globalization, development, trade and aid, technical assistance, demographics, emerging markets, policy advice, poverty reduction, and so much more".
- **HEINONLINE:** HeinOnline is a premier online database containing more than 173 million pages and 270,000 titles of historical and government documents. HeinOnline bridges an important research gap by providing comprehensive coverage from inception of more than 2,700 law-related periodicals, and contains the entire Congressional Record, Federal Register, and Code of Federal Regulations back to 1754. Entire databases are dedicated to treaties, constitutions, case law, world trials, international trade, foreign relations and much more.

Information Retrieval System

The library is continuously introducing user-focused innovative information access and retrieval systems. The library is using state of the art Integrated Library System VIRTUA, which provides remote and free access to its library catalogue, secure access to user accounts, and other personalized services. Multiple access points are available for users to search and download full-text resources. They are:

- **The Library Website** (<http://library.lums.edu.pk>) provides a comprehensive gateway to a wide range of library materials, both online and in print. It is a primary source for information about library collections, services and facilities. User self-sufficiency and ease of access are promoted by designing a single, coherent, remotely accessible service.
- **CHAMO Library Portal** (<http://libraryportal.lums.edu.pk/>) provides access to library catalogue and secure access to patron accounts. Users can carry out many transactions like reissuing books online, reserving checked out items, viewing fine details, initiating book purchase requests, exporting bibliographic records, and reviewing, ranking and tagging of library items. Patrons can save a search query for future retrieval, set alerts by email, and use RSS for books and journals of their interest.
- **Web Discovery Service** (<https://search.ebscohost.com>) The Web Discovery Service searches seamlessly across a wide range of local and online resources including library catalogue, online journals, e-books and other contents through one window interface.
- **Course Guides:** Library Course Guides enable the users to find their required contents on specific subject areas through a customized interface. Guides on all disciplines related to the courses offered at LUMS are developed and regularly updated by the relevant library staff.
- **Full Text Linking from SCOPUS and Google Scholar:** The Library has enabled full text linking of subscribed contents from the world's most popular search engine Google Scholar and the largest peer-reviewed indexing source SCOPUS. Users can get required full text while searching from these sources.

Library Environment

The Library is a pollution free area – no eatables, mobile calls, loud discussion, and drinks (except soft water) are allowed in the library.

Interlibrary Loan

The Library also supports research activities through electronic document delivery services, interlibrary loans and cooperation arrangements with leading local and international libraries and information centers.

Citation Management Tools

Provision of access to a variety of citation management tools like Endnote, Mendeley and Zotero through the library is another step towards augmenting research activities at LUMS. These software(s) facilitate in keeping track of research resources as well as inciting these resources in one's research. Library website also presents a comparative analysis of various citation tools thus facilitating selection of the most suitable one. Moreover, library facilitates in utilizing plagiarism detection and management tool Turnitin. As part of publishing support library provides its services in the creation of book indexes through various software.

Information Literacy Sessions

LUMS library is imparting information literacy among its users through Research Skills Enhancement Sessions, orientations of newly entrants and in class sessions. These sessions help to enhance library users' understanding regarding library resources and services.

The professional staff is available seven days a week to render efficient lending and reference services. Online databases are accessible both from the terminals in the library and from the campus-wide network.

Opening Hours

The Library is open seven days a week and around-the-clock during exams.

Monday – Friday 0830 hrs to 0200 hrs

Saturday 1000 hrs to 1000 hrs

Sunday 1000 hrs to 1000 hrs

Library remains open around the clock during exams.

Helpdesks on both floors provide proactive services from 0830 hrs to 2000 hrs (Monday to Friday).

The Library remains closed on public holidays

Library Usage Policy

- Users can bring their personal belongings such as handbags, briefcases, etc., inside the library at their own responsibility.
- Submit any book for inspection, when requested by the library staff.
- Do not write, underline or mark any book. Library books are carefully examined on return, and the borrower is held responsible for any damages.
- Please leave books on the table or the book trolley after reading. Please do not shelve the books.

- Complete silence should be observed
- except for brief and subdued talk with the library staff.
- Drinks and eatables are not allowed in the library.
- Smoking is strictly prohibited in the library.
- Keep your mobiles switched off/silent within the library premises.
- Students wearing shorts are not allowed inside the library.
- Do not change the configuration of computers or any other equipment in the library. LUMS IT code of conduct must be observed while using IT applications.
- Library is not responsible for any losses; please do not leave your belongings unattended.
- Presentation of a valid library card is a must for any checkout at the circulation desk.
- Loan may be renewed if another user has not reserved the desired book. Overdue books will not be renewed online.
- Books already checked-out by some other user can be reserved. You can also request reserving the book through iPortal.
- Reference material, CD-ROMs, annual reports, pamphlets, current and bound periodicals, IA (industrial advisory) reports, thesis / dissertations, student's projects and newspapers cannot be checked-out. They can only be consulted within the library premises.
- Photocopying facility is available where copyright rules permit. Patrons can get photocopying cards @ Rs.60/- per card from the library after making payment in the Bank.
- If you accidentally misplace a book and could not find it after a thorough search, report this to the Circulation Desk immediately to avoid overdue fine.
- Mutilation of library material can lead to a disciplinary action against the perpetrator. Books accidentally damaged should be reported so that suitable assessment can be made and damages can be collected / imposed.
- Library material borrowed by any member is subject to recall if needed by the library. A fine may be imposed if the recall request is not entertained.
- Any material not returned or renewed within 60 days of the due date is considered LOST.
- Library is not responsible for any losses; please do not leave your belongings unattended.

Lending Rules

Students become members of the library on their admission at LUMS. However, they are required to sign the "Relationship Form" to activate their membership. All registered users are entitled to borrow materials from the library. Borrowing privileges may differ depending on the membership category. The borrowing privileges for course reserve* and general books are:

*Course reserve is issued for three hours.

MEMBERSHIP CATEGORY	BORROWING PRIVILEGES	DAYS
Undergraduate Students	8 books	14
Graduate & Postgraduates	15 books	14
Teaching Assistants	8 books	14
Research Associates	15 books	14
Faculty	30 books	120
Staff	4 books	14
External Members	4 books	14

Fines

To encourage timely return of library materials and to provide optimal sharing of the collections, fines are charged for overdue items. Borrowers are responsible for returning or renewing items by the due date. If items are not returned within the due date, fines become retroactive to the first overdue day at following rates.

- Overdue Books: Rs.10/- per book per day.
- Lost Books: In case of loss or damage, the patron is charged three times the current price of the item.
- Course Reserve: This material is issued for three hours only. If the material is not returned within the allocated time, a fine of Rs.50/- for each extra hour is charged.
- Disciplinary Fine: Rs. 500/- on first time violation, Rs. 1000/- on second time violation. If the patron continues, the case is referred to the Disciplinary Committee.
- Overdue and fine notices are sent through official email. All library fines are only paid with the Accounts department. Library account is blocked if the fine exceeds Rs. 5,000/-

INFORMATION SYSTEMS AND TECHNOLOGY (IST)

Teaching and Learning at LUMS is technology – intensive. LUMS offers a rich and diverse computing environment that effectively meets the productivity requirements of its students, faculty and staff. Information Systems and Technology (IST) supports academic and administrative computing systems and spearheads IT-initiatives to ensure adequacy of the technology infrastructure.

Each day, the LUMS community plugs into a vast campus network. Those who are off -campus, have secure, web-based access to on-line course support services such as enrollment, assignments and grades, message boards, and e-mail. Wireless access is available in all the buildings, covered areas and in the student sitting area outside of KHOKHA. Internet access at LUMS is fast and reliable. The campus currently consumes a total of 1.5 Gbps of internet bandwidth across its labs, offices, and residences.

Computing Labs

There are eight general-purpose computing labs with approximately 512 PCs at LUMS. Four computing labs are located on the second floor of the library building, one lab with 82 computers in the SDSB building ("Trading Lab"), one lab with 60 computers in the SBASSE basement ("Sohail Aslam Lab"), one lab with 102 computers in SBASSE ground floor ("Programming Studio"), one lab with 20 computers in LAW ground floor ("UBL Lab"). Computing resources, printing facilities and support in the library building labs are available 24x7. All the computing labs are equipped with high-end workstations, document scanners and high-speed laser printers. In addition, kiosks have been placed, outside the library and Lab 2 for quick access to email and the web.

Apart from the general computing labs facility, there are four computing labs in SBASSE, having seating capacity of 25 computers each. These labs are located on 2nd, 3rd, 4th and 5th floor of the SBASSE building. A student may reserve a PC in the lab with custom installation of required software or hardware. Computing labs may also be reserved for a fixed period exclusively for specific group at the request of a faculty member, authorized staff and president of society. Lab reservation hours are posted by the lab staff and students are expected to observe them.

Email

Every student is provided with a LUMS email account, hosted on Microsoft Office 365 cloud services. Webmail is accessible via <https://outlook.office365.com/>. Students are strongly advised to check their emails regularly as communication between most departments and students is through this channel. At times homework is also assigned over email.

Printing Services

Laser printing facility is outsourced to vendors. Printers are spread throughout the campus. Contractor shop(s) are located above the Superstore where you can pay and get the printing quota.

Academic Software

Academic software that IST provides in computing labs are:

Microsoft Office including MS Visio and Project, MS Visual Studio, MS Visual Studio. Net, Matlab, Mathematica, STATA, Oracle, SQL, Grader, WinZip, ERP Client, Adobe Acrobat Professional, Adobe Photoshop, Adobe Illustrator, Microsoft Publisher, Oracle Client Configuration, SPSS with AMOS, Stata TSP, Eviews, Matlab, Scientific Workplace, Maple, MicroC Pro, Mathematica, Scientific and Palisade tools. ChemDraw Ultra, Lab View, GFI Client, Peachtree, Crystal Reports, Stella and Winedt, access to Data Stream, OSIRIS, Softech, Bloomberg databases. Abby fine reader, ArcGIS, Atlas, Axure, Edraw, Endnote x8, Graphpad, Inpage, Kaleida graph, Lync client, Math type, Maxqda, Nero,, NVIVO, Prism 6, PSIM, Sanp Gene, SAP Presentation Desk, Simio, Starpls, TSP, XPS

LUMS has also subscribed to the Microsoft Developer Network (MSDN). Any software that is available through the MSDN subscription can be installed per request on the computing lab per class requirement.

Student Information System (Zambeel)

Zambeel is a consolidated online platform used by the LUMS community to access information and record transactions related to:

- Student Personal Information
- Sole Medium of Student Record
- Semester Registration and Enrollment
- Term Schedules
- Student Financials
- Academic Advising
- Grading
- Graduation Requirements

Students have to use their respective campus ID and password to access Zambeel self-service from the web (<https://zambeel.lums.edu.pk>) or the *Zambeel* android/iOS app.

Important: *It is vital that you do not share your password with anyone.*

Learning Management System (LMS)

Sakai, the learning management system used at LUMS, provides a convenient online environment for teaching and learning, as well as student-faculty collaboration. Features include assignment management,

course material upload, course websites, online discussions, as well as the ability to conduct online quizzes and to grade them.

Students have to use their respective campus ID and password to access LMS via <https://lms.lums.edu.pk>

Video Conferencing Facilities

Video conferencing facilities are also available on-campus, enabling students and faculty to effectively collaborate with researchers and scholars across the globe. The University has conducted thousands of successful video conferencing sessions with national and international groups and individuals during the last few years. Video conferences are sponsored by faculty members at LUMS and require advance scheduling. For more details, please contact the IST Helpdesk.

Lecture-Capture and Streaming

Many lecturers choose to use lecture-capture technology where class lectures are recorded and placed online as soon as the class completes, providing students a great resource to refer to while preparing for exams or in case they skipped a lecture. IST offers live streaming/broadcasting of events through the Facebook pages. LUMS has successfully broadcasted a number of events including the Convocation Ceremonies.

Information Security

(InfoSec@lums.edu.pk)

Information Security team at LUMS is responsible for incidents such as password theft, compliance against Government regulations, unauthorized access etc.

However, instead of relying entirely on information -security professionals to prevent infiltration and minimize vulnerabilities, this team facilitates behavioral change and develop a culture of continuous learning and security awareness.

Queries/concerns about Information Security Policies are also managed by this team

LUMS IST Helpdesk

The LUMS IST Helpdesk is a technical support team that provides prompt, knowledgeable and courteous desktop computing support services over the phone, in person, and via web and email to LUMS. The Helpdesk aims to resolve all interactions with at least 80% or above satisfaction. If this is not possible, the inquiry is escalated to provide alternative referrals or resources. If the problem or request concerns an unsupported operating system, hardware, software or service, staff will do their best, given call volumes, to suggest other avenues of support. The helpdesk mission is to ensure a positive experience and a speedy resolution resulting in the efficient use of technology tools for our academic setting.

Computer Lab Usage Policy

LUMS computing facilities are designed to be used in connection with legitimate, University-related purposes. The following are considered as rules of computing lab usage. Failure to abide by these can result in the offender's account being disabled for a certain period, plus a monetary fine or a referral to the Disciplinary Committee.

General:

- Access to computing labs is only allowed to students with identification. Lab staff may request students to produce their LUMS student ID card and may request to leave the lab otherwise.
- IST strives to maintain a quiet, work friendly environment in its computing labs in order that lab users can use their time productively and with minimal distractions.
- Computing Labs are a work area; therefore, no food or drinks (including water) are allowed.
- Students are responsible for ensuring the confidentiality of access rights under their control. For instance, release of a password, whether intentional or inadvertent, invites misuse by others may be subject to disciplinary action.
- Damaging or misusing the lab equipment and furniture can result in penalties.
- Putting feet on the chairs and sleeping in the labs is not allowed.
- Installation of any software without permission of the IST staff is not allowed.
- Playing games is strictly not allowed in any of the computing labs.
- Use of computing and communication resources to support a profit entity (including any personal business) is strictly forbidden.
- Illegally downloading any copyrighted material (e.g. software, music, videos, books, photographs, etc.) is prohibited.
- Students should not leave papers, trash, books or bags on computer terminals/desks.

Hostel LAN/Wireless Usage Policy

The campus network is a facility that is to be used responsibly at all times by all members of the LUMS community. Hosting and transmitting material which is designed or likely to cause annoyance, inconvenience or needless anxiety to anyone is against usage norms, and will lead to action against individuals and groups involved in such activities.

- Internet Browsing from Hostels is monitored and students are advised to avoid accessing pornographic material or any objectionable site. In case a student is found browsing through objectionable site, serious action leading to the termination from the registered programme is taken
- Password sharing of any server of LUMS is considered as violation of the computer usage from the hostel. In case any attempts or activity is recorded from the login of a student, his/her account is disabled along with that of one whose password was used.
- Use of hacking tools and attempts to hack campus equipment will lead to the disciplinary action including termination of the room computer node for indefinite period.
- Disabling of room node(s) is made in case the activity falls under hacking, scanning etc. or the log in shows access to objectionable sites, or attempts to compromise other internet sites from the hostel LAN.
- Access to P2P sites is limited as they consume a lot of internet Bandwidth and may contain illegal material.
- Setting up personal or any wireless access point or routers without IST's prior written permission.

Note: In case of a violation, disciplinary action is taken against the student as per University rules and regulations.

Violations & Fines:

- Penalty for sending out mass emails can range from a fine of Rs. 5,000 to Disciplinary Committee referral.

- Allowing a fellow student to use your account will result in a penalty of Rs. 3,000.
- Violating lab rules for the second time will result in a penalty of Rs. 3,000.

Disciplinary Action:

- The use of computing resources to disseminate obscene, pornographic, or libelous materials, to threaten or harass others, or otherwise to engage in activities forbidden by this Code.
- Tampering with the lab surveillance system
- Email spamming and email wars
- Dropping malicious code using methods like Phishing emails etc.
- Use of another individual's identification and/or password
- Placing or offering any kind of commercial or indecent services from individual web pages
- Misbehaving with lab support staff and other IST staff
- Installing personal Wireless Access Points (APs)/Wireless Routers without permission anywhere in the campus will be subjected to appropriate disciplinary action and the device(s) will be confiscated.
- Manipulating with wireless devices will be subjected to disciplinary action; the actions include moving the antennas direction, relocating APs or manipulating AP power.

Important:

- LUMS maintains a comprehensive log of all user activity performed on workstations in computing labs. These user logs can, and are, referred to when an event of misuse of resources is reported.
- In case of these violations, even first time offenders are referred to the Disciplinary Committee.
- In case of any query your first point of contact is the lab support staff available on -site. You may also email your concerns to helpdesk@lums.edu.pk.

Contact Information

General Email	helpdesk@lums.edu.pk
Phone	042 3560 8000 Ext:4150 / 4149
Hours	Monday to Friday 8:30 am till 10 pm
	Saturday and Sunday 9 am till 6 pm
Customer Services Manager	Khubaib Nazir (khubaib@lums.edu.pk)
Director IST	Faisal Kheiri (faisal.kheiri@lums.edu.pk)

GENERAL ADMINISTRATION SERVICES DEPARTMENT (GAS)

The General Administration & Services department is responsible for providing support to all the activities of the university in coordination with other departments. Key responsibilities include the implementation of all General Administration & Services policies. Following are the areas:

- Security of Community, Campus & Assets.
- Facilities & Engineering (HVAC, Electrical & Civil)
- Dining facilities for the community i.e. PDC, EDH and Food Courts.
- Transport services.
- Campus traffic, vehicle entry & parking system.
- Travel Services (road/air)/National/International /Visa Services & Hotel Reservations.

- Smart card & its implementation.
- Venue bookings for events.
- Mail & courier services.
- Classroom staff in terms of services & maintenance of auditoriums & classrooms.
- Janitorial services ensuring neat & clean campus.
- Horticulture for maintaining Sarsabz LUMS & green campus.
- Space allocation & accommodations.

Smart Card Usage Guideline for LUMS Community

Scope and Applicability

LUMS smart card is an official ID of each community member, which will provide its owner authorized access to key University facilities including office blocks, student hostels, library, computing labs, sports complex and the aquatic center.

The policy is applicable to:

- All LUMS Community.
- Alumni.

The LUMS smart card will only grant access during the hours of operations of the different facilities on campus.

Applicable Policies

- It is mandatory that each student and alumnus obtain their LUMS smart card from the main security office of the University.
- It is mandatory to carry your smart card all the time when on campus. A University security representative can ask you for identification, and without the card you will not be able to access various locations on campus.
- The issued smart card will be valid for the entire duration of user's degree period.
- Cards are not transferable from one person to another. Only the person pictured on the card is authorized to use the card.
- For graduating classes, student's smart card would be returned to security office for issuance of Alumni card. Returned smart card will be de-activated right after the issuance of Alumni card on their graduation ceremony.
- In case card is lost or stolen, the card owner must inform Security office immediately through an email at vigilance@lums.edu.pk so that access privileges can be timely revoked to prevent any untoward security incident.
- Once issued in a working condition, the protection of the smart card is a sole responsibility of the user. In case of non-functional or worn-out card, the decision of the issuing authority will be considered as final. The cardholder will be charged a card replacement fee.
- Student user profiles are retained by LUMS for a period of three months after graduation.

Note: Students on financial aid can file their appeal for smart card fee reduction through Financial Aid Office. LUMS reserves the right to withdraw the card at any time.

Policy Violations

Extending access rights by lending card to someone else or helping other people to gain unauthorized access to facilities (tail gating).

Tampering with access control hardware and surveillance devices, theft and damage to University property e.g. door, glass, access control hardware, surveillance cameras etc.

User Forgets to Bring Card

In case a user forgets to bring his/her card at work, he/she should visit LUMS security office adjunct main IN Gate. However, there would be a usage limitation applicable in order to discourage people from making this a habit.

Penalties and Fines

If violations are proved against a person, his/her Smartcard would be immediately deactivated, and fines up to 20,000 PKR (Twenty Thousand Pakistan Rupees) could be imposed. In case of theft and damage to University property additional fines may be imposed.

Serious violations of the policy will be referred directly to the appropriate Disciplinary Committee, and could result in severance from degree programme.

Lost or stolen card

The loss or theft of a smart card must be notified to the LUMS security office immediately in person. The cardholder credentials can also be verified from the LUMS active directory through his campus ID.

In case the cardholder is not able to visit the said office, he must inform security by sending an email from LUMS account on vigilance@lums.edu.pk and reconfirming status via telephone within next twelve hours (Ext : 2560).

It is not possible to prevent the unauthorized use of a lost or stolen smart card until it has been reported by the registered cardholder to the security office for deactivation. Until it is deactivated, the user will be liable for the unauthorized use of the smart card.

Replacement Cards

A replacement smart card will be issued at a charge of 1,500 PKR (One Thousand, Five Hundred Pakistan Rupees). The replacement smartcard will have the same validity. Students on financial aid will be expected to file their appeal for relief through the Financial Aid Office.

Note: Relief of 850/- PKR can be extended to a student

Penalties related to violating the Security System.

The following penalties are in effect to make the access control system effective. All charges will be backed by material evidence.

Students are informed via email and penalties are charges along with the fee/hostel charges.

Violations	Description	Penalty
Tail gating	Helping others intentionally to gain access, on your smart card	Warning + 1000 & on second attempt card is blocked.
Door Held Open	Holding the door open physically for a longer duration, in access with the standard allowed time i.e., 7 seconds.	500
Door forced open	Using any material/ item to block/break or open the door, so the door remains unlocked	Warning + 5000 & on second attempt case is sent to DC
Tampering/ damaging the hard ware	Interfere with the access control hardware with intention to harm / disable/damage its function	10,000 to 20,000 with DC
Unauthorized access	Lending your smart card to the unauthorized person /outsider to gain access in your absence	20,000 + DC (Offense)

In case of any query, feedback, information or help please contact the security office (Near In Gate) or at telephone +92-42-111-11-5867 (ext. 2560) or email us at: vigilance@lums.edu.pk

IN CASE OF ANY EMERGENCY, PLEASE CALL 042 -35608877

Campus Parking Policy

This policy applies to the use of University parking facilities by faculty, staff, students and visitors. The overall responsibility of parking rests with the General Administration & Services Department (University administration). Vehicle entry stickers have been redesigned as per parking lots.

Parking fees and conditions are established by the University administration, which are as follows:

- Parking stickers can only be given to LUMS community holding smart cards.
- Valid vehicle documents must be in possession while getting the sticker issued.
- The sticker will be pasted by the respective staff on the vehicle.
- The stickers will be issued as per financial year and design / colour will be changed every year
- Two vehicle stickers can be issued on one smart card.
- Parking is permitted in designated parking spaces only. Parking along campus roadways, interior paths, or on campus landscaping is prohibited.
- Sleeping overnight in vehicles on campus is prohibited.
- No vehicle repair or maintenance will be made on campus except under emergency conditions with the approval of the LUMS General Administration and Services.
- LUMS Security Office must be informed in case of temporary parking of a vehicle on campus for longer duration. The University administration reserves the right to cancel any parking privileges as deemed necessary.

- In exceptional circumstances, such as for handicapped faculty, staff, students and visitors or special University guests, the University administration reserves the right to authorize the use of specific parking place at its discretion.
- The University administration reserves the right to close parking facilities when conditions warrant.
- The University administration is authorized to examine upon request, the contents of all vehicles on University premises in the presence of the owner. Refusal to submit to such examination may result in the immediate loss of parking privileges.
- The LUMS community must adhere to the parking policy, park the vehicles as per parking stickers and observe traffic signs. Failing which, a warning will be served by pasting a slip on the vehicle and subsequently a repetition will result in a fine, as follows:
 - Speeding 1000/- PKR
 - Wrong parking 1000/- PKR
 - Blowing horns 500/- PKR
- The campus speed limit is 20 km per hour.
- Overnight parking is prohibited except campus residents unless authorized in advance by the General Administration Department.
- The University assumes no responsibility for loss, theft or damages to vehicles parked in University parking premises. Owners are expected to lock their vehicles.

LUMS Entry Policy / Visitor Policy

Policies and Procedures The following guidelines cover the policies and procedure for all users:

- Visitors shall be required to cooperate with the Security staff while undergoing entry procedures.
- The entry timing for visitors shall be from 8:30 am to 10:30 pm. The visitors related to students, faculty and staff shall be allowed to visit the campus within the defined visiting hours only. The visitors shall leave the campus at or before 10:30 pm and no later than that.
- The concerned student shall come to the security office and deposit his/her Smart Card.
- Before entering LUMS, any member of the LUMS community (faculty, staff, students and alumni), without possession of the Smart Card shall be verified through the System in the control room for the satisfaction of the security.
- Drugs and weapons are not permitted on campus; therefore, a visitor carrying such items will not be allowed to enter the University.
- A visitor will only visit the office/individual that has been registered with the security control room. If he/she is found in an unauthorized area/office by the security staff, the visitor will be asked to immediately report to the security control room.
- A visitor shall be issued a Visitor Pass after endorsement of credentials and confirmation from the LUMS community member who he intends to meet. This pass must remain in possession of the visitor for identification within the campus and should be returned upon exit.
- On arrival of guests, students are required to submit their University Smart Card with the security supervisor on duty. The guest's CNIC or authorized legal driving license (original) shall be submitted with the security supervisor at the main gate. Guests not in possession of any valid identity will not be able to enter the premises.
- The Visitor Pass will be returned to the issuing authority after signing out.

- The visitor will not be allowed to stay overnight on campus, without a prior approval from the authorities nor visitor cannot enter the classrooms/labs/hostels/library/Sports Complex/discussion rooms.
- The visitor will not be allowed to stay overnight on campus, without a prior approval from the authorities.
- The Visitor Pass will be returned to the issuing authority after signing out.
- The visitor will park his/her vehicle at the visitor parking area only.

OTHER FACILITIES AVAILABLE AT LUMS

Student Lounges and Common Rooms

Student lounges are built within all the school buildings at LUMS, and common rooms are made in the main dining center building for all students. These designated areas offer students a space to interact outside of study time and the lounges are devoted to enhancing the student experience and campus life.

Common rooms and lounges are also present in each of the male and female hostels. Each residential facility features common rooms with large screen TVs and comfortable seating. All common rooms are air-conditioned and open 24 hours. Students should keep in mind the following rules:

- Residents are only allowed to sleep in the lounges during the summer months
- Personal belongings should not be left unattended in the common spaces
- The university cannot be held responsible in case of loss of personal property

The SDSB building houses the Student Lounge for the MBA students on the second floor of the building, while the PhD students have working spaces allotted to them on the second and third floor. There is a separate student's lounge in the PDC building on the first floor, which is open to all undergraduate students.

Dining Services

- **Cafeteria**

The Pepsi Dining Centre (PDC) provides three meals and snacks on daily basis. The operation starts at 7am and ends at 10:30pm. PDC caters variety of snacks and meals to the community.

For information on the Pepsi Dining Centre please visit <http://pdc.lums.edu.pk/>

- **Food/Commercial Outlets**

There are 9 different food outlets and 7 commercial shops including a pharmacy, salon, superstore, bookstore and photocopier within the campus, where edibles and everyday routine stuff are available to the students.

Banking & ATM

- **Campus Banking**

Allied Bank digital branch in commercial area building provides consumer banking services to LUMS community. We have four ATM machines on campus:

- Allied Bank ATM (Infront of PDC & Superstore Area)

- MCB ATM (School of Law)
- Askari Commercial Bank ATM (Suleman Dawood School of Business)

- **Student Payments**
Students and parents can make student account payments through the online payment system: <https://admission.lums.edu.pk/student-payment-options-0>

- **Emergency**
LUMS Emergency Services are available round the clock at Emergency Direct Number: 04235608877

- **Pharmacy**
LUMS also provides a 24/7 operational pharmacy on-campus which helps the community in procuring essential medications.

It is operational throughout the year and is easily accessible to the campus community. Each design and item is crafted meticulously, complementing the LUMS alumni, faculty, students, and visitors we serve, capturing the classic essence of LUMS, its tradition, its history, and its timelessness.

Masjid

The campus has a beautifully designed, community masjid, which is open 24 hours a day. Daily sermons are delivered in both Arabic and Urdu. The spacious mosque offers separate prayer facilities for men and women and is operational in all seasons of the year.

USEFUL CONTACTS

Department	Email / Web Address
Admission Office	helpdeskao@lums.edu.pk
Alumni Office	alumnirelations@lums.edu.pk
Development	giving@lums.edu.pk
Student Support Services	cso@lums.edu.pk
Co-curricular Activities	cca@lums.edu.pk
Finance Department	helpdeskar@lums.edu.pk
Financial Aid	ofa@lums.edu.pk
General Administration Services	vigilance@lums.edu.pk
IST	helpdesk@lums.edu.pk
Library	http://library.lums.edu.pk
Office of Advancement	communications@lums.edu.pk alumnirelation@lums.edu.pk giving@lums.edu.pk
National Outreach Programme	nop@lums.edu.pk
Office of Student Affairs	osa@lums.edu.pk
Office of the Registrar	https://roservice.lums.edu.pk helpdeskro@lums.edu.pk
Office of Sports, Wellness & Recreation	swr@lums.edu.pk
On Campus Residence	residence@lums.edu.pk
Office of Programme Enhancement	ope@lums.edu.pk
Office of International Affairs	https://www.facebook.com/OIALums/
Centre for Continuing Education Studies	ces@lums.edu.pk

SUBJECT AREAS AND COURSE CODE PREFIX TABLE

Subject Area	Code Prefix
ACCT	Accounting
ACF	Accounting and Finance
ANTH	Anthropology
AST	Astronomy
BIO	Biology
BUSS	Business
CHEM	Chemistry
CHE	Chemical Engineering
CLCS	Comparative Literary and Cultural Studies
CMPE	Computer Engineering
CS	Computer Science
DISC	Decision Sciences
ECON	Economics
EDU	Education
EE	Electrical Engineering
EMBA	EMBA
ENGL	English
FINN	Finance
GSL	General Studies Law
GSS	Gender and Sexuality Studies
HIST	History
LANG	Language
LAW	Law & Policy
MATH	Mathematics
MECO	Managerial Economics
MGMT	Management
MKTG	Marketing
ORSC	Organizational Sciences
PHIL	Philosophy
PHY	Physics
POL	Political Science
PSY	Psychology
SALT	South Asian Literature
SOC	Sociology
SS	Social Sciences
SWR	Sports, Wellness & Recreation

GLOSSARY

Academic Advisor

A faculty member or a trained advisor assigned to a student, who, through regular meetings, helps the student plan and implement immediate and long-term academic and vocational goals.

Academic Holiday

Day(s) when no classes are held but administrative offices remain open.

Academic Probation

A period or duration of observation/evaluation applicable to a student whose academic performance falls below the LUMS requirement for good academic standing. A student is placed on probation if his/her CGPA falls below 2.0 at the end of any regular semester. Upon not meeting the University defined conditions, a student placed on probation may be separated from the programme.

Academic Programme

A course of study to which a student applies, is admitted and graduates.

Academic Warning

A period or duration of observation/evaluation applicable to a student whose academic performance falls below the defined LUMS requirement. A warning letter is issued to students on the following basis: If semester GPA in any regular semester falls below 2.00, regardless of CGPA. - If CGPA is below 2.5.

Academic Year

The Academic year comprises of two regular semesters, the Fall and Spring semesters. Each semester is of 16 weeks, comprising 15 teaching weeks including reading and review period and a final examination week.

Active Student

An undergraduate, graduate or postgraduate student who is pursuing a degree at LUMS

whether enrolled or on leave in a particular semester/academic year will be considered as an active student.

Administrative Staff

A "professional, executive, or administrative" staff position that meets the labour laws for executive, administrative, or professional status. Individuals in these positions are not eligible for overtime compensation.

Admission Cancellation

Cancellation of admission of a student at any point in time by the University.

Admission Fee Waiver

A waiver given on admission fee.

Admitted Student

Applicant who has accepted the admission offer after meeting all the stipulated conditions of offer. The candidate who has met the LUMS admission criteria, has accepted the admission offer and the requisite terms and conditions.

Alumni Card

A LUMS identity card given to alumni for access across campus and to avail discount offers at major retail outlets and eateries across Pakistan.

Alumni

Alumni are defined as individuals who have completed requirements for a degree programme at LUMS.

Applicant

A person who applies and successfully submits his/her admission application through the LUMS Online Admission system.

Audit Student

An external or LUMS' student who takes a course without the benefit of a grade, credit or certification.

Bachelor's Degree

An award that normally requires full-time course work of at least four years but not more than six years for all undergraduate

programmes except BA-LLB. For a five year BA-LLB degree, maximum allowed completion time is seven years.

Bona-fide Letter

Bona-fide letter is a certificate which is issued by the University to students, which could include details pertaining to their admitted/graduation year, adherence to discipline, level of study, major field of study, medium of instruction and CGPA/SGPA as required by different officials i.e. recruiters, higher education institutions, funding organizations and for visa purpose etc.

Bona-fide Student

A student who is/was pursuing a degree programme at LUMS and has never been dismissed on disciplinary grounds.

Class Enrolment

The number of students enrolled in a class.

Closure

A closed activity that is not active at this moment.

Conditional Admission Offer

Admission offer made to an applicant where s/he is yet to meet the stipulated condition(s) for the confirmation of admission.

Consultancy

Consultancy is defined as an activity that a member of LUMS community carries out within or related to his or her professional field through which expertise is exchanged against some consideration with an external organization i.e. client. Work is classified as consultancy when: 1. The project involves purchase of the existing skills, knowledge and expertise of University staff and equipment by a client; and 2. The client expects to own the intellectual property (IP) arising from the paid consultancy and also expects complete confidentiality on the part of the University.

Consultancy work normally includes short-term investigations.

Course Audit

A course taken without the benefit of a grade, credit or certification. The purpose is self-enrichment and academic exploration only.

Course Catalogue

A repository which is maintained in Student Information System (Zambeel) to view all courses and related information.

Course Enrolment

Course enrolment is the process of adding/dropping/swapping of courses each semester within the pre-defined enrolment phases using Student Information System (Zambeel).

Course Load

The number of credit hours that each student takes in a regular semester. The University defines the programme and level wise requirements for minimum/maximum credit hours in a semester.

Course

A unit of teaching that normally lasts one semester, is led by one or more instructors and has a fixed number of students. It is typically described in course catalogue. Courses can contain multiple components such as lecture, recitation, tutorial, lab etc.

Credit Hour

A unit of measuring educational CREDIT, usually based on the number of contact hours per week throughout a semester. "A credit hour means teaching a theory course for 50 minutes each week throughout the semester. One credit hour in laboratory or practical work/project would require lab contact of 03 hours per week throughout the semester".

Credit Transfer

Successfully transferred credits of course(s) taken by a student at any other university during an exchange/visiting semester.

Credits

Recognition of attendance and performance in an instructional activity (course or programme) that a student is given credit to meet the requirements of a degree.

Cross Listed Courses

A single course which is offered with two or more course codes for the relevant areas. A student may register for the course with only one prefix that is pertinent to his major/minor field of study. The course will count towards the chosen area for the duration of the programme.

Cumulative Grade Point Average (CGPA)

Sum of all grade points divided by total credit hours attempted.

Dean of School

The dean of the school is the academic and administrative head of all department(s) within a School (i.e. MGSHSS, SBASSE, SAHSOL, SDSB) with the responsibilities of faculty hiring, implementing academic policies & standards, overseeing the budget and other administrative functions.

Dean of Student Affairs

The dean of student affairs is responsible for the student well-being and experience at the university including the extra-curricular activities.

Dean

The Dean of School brings together all aspects of the student experience. He is responsible for overseeing the curriculum, especially the aspects related to general education, as well as all non-curricular components of student life.

Dean's Honour List

The students are placed on the Dean's Honour list upon successful completion of at least 32 credit hours in a year and attaining cumulative GPA of 3.60 or above.

Degree Before Convocation (DBC)

Degree before convocation may be issued prior to graduation to the students who have completed all the degree requirements for their programme and their name has been approved in the faculty plenary.

Degree

An award conferred by LUMS at the time of graduation, as official recognition, for the successful completion of a programme of study.

Department Chair

The department chair is responsible for delivery of effective curriculum, facilities management and related services in an academic department. This person provides a key communication link between the administration and the departmental faculty.

Doctorate (PhD)

A degree that requires advance work beyond the master's level, including the preparation and defence of a dissertation based on original research, or the planning and execution of an original project demonstrating substantial artistic or scholarly achievement.

Double Major

An additional major chosen by a student in the junior/senior year of study, subject to availability of seats and fulfilment of requirements. In order to complete a double major degree a student is required to complete at least 160 credit hours.

Drop a Class/Course

The process of dropping a course/class that a student is enrolled in within the stipulated period.

Dropout

A student who leaves the university prior to completion of degree. Following conditions apply:

1. Un-authorized withdrawals;
2. University withdrawal;
3. Administrative Withdrawals.

Enroll

The process to register for course(s) in a semester.

Enrolled Student

An undergraduate, graduate or postgraduate student who is pursuing a degree at LUMS and is enrolled in a particular semester/academic year will be considered as an enrolled student.

Executive Courses

Courses offered for professionals by Rausing Executive Development Centre (REDC) at LUMS.

Extracurricular Activities

Activities undertaken by students that fall outside the realm of the normal curriculum of school or university education.

Faculty Member

Faculty members who are responsible for planning, directing and undertaking academic teaching only, research only or both teaching and research at LUMS. A faculty member can also hold an administrative position as designated by the University. Only adjunct faculty members are counted as part-time faculty members.

This includes: vice-chancellor, Deans, professors, heads of academic departments, associate professors, assistant professors, teaching fellows, research fellows or postdoctoral researchers, adjunct, visiting faculty members who contribute to teaching or research or both at your university for a minimum period of at least three months.

Faculty Workload

“Faculty Workload” refers to all faculty activities that contribute to the accomplishment of School related activities and responsibilities: research/creative activity, teaching and service.

Fee Paying Student

An undergraduate, graduate or postgraduate student who is paying fee (irrespective of fee source) to the University in a particular semester/academic year

will be considered as a fee paying student.

Fee Waiver (Hostel)

A waiver given to a student on hostel fee.

Fee Waiver (Tuition)

A waiver given to a student on tuition fee.

Fee waiver

A fee waiver is a form of financial aid made by LUMS to a student on a need/merit basis.

Fees

The pre-defined charges for educational and other related services by the University.

Final Exam

A final examination is a graded instrument given to students at the end of a course offered in a semester.

Final Separation

A student who has been permanently separated from the programme based on academic performance and is not eligible to apply for readmission.

Financial Aid (Loan)

Financial support from University's side to students for paying LUMS Fee which needs to be returned after graduation.

Financial Aid

Need based monetary support to a student to help pay tuition, fees and other educational expenses. This can include loans, grants, scholarships.

Financial Awards

Financial award is any grant or scholarship, loan, or paid employment offered to help or encourage a student. Such aid is usually provided by various sources such as federal and state agencies, foundations, corporations, donor organizations or University.

Foreign National applicant

An applicant who is not a Pakistani citizen and does not hold a

Pakistani passport/NICOP/CNIC. Applicants holding dual nationality out of which one is Pakistani are not considered as foreign national.

Free Elective Course

A course which student can freely choose to fulfil overall degree requirements. The requirements for free electives vary across degree programmes.

Freshman (First Year Student)

An undergraduate student in the 1st year of university study. At LUMS, student levels are categorized according to the number of credits earned during their academic career. The level of student remains freshman if the earned credits are within 1 - 30 credit hour range.

FTE-Student (in a semester)

Number of students who have taken full course load of 12 credit hours for undergraduate and 6 credit hours for a graduate level academic programme in a given regular semester. Formula to calculate FTE in Undergraduate Programmes: $(FTE = \text{full-time headcount} + (\text{part-time headcount}/(\text{full credits i.e., } 12/\text{average of credit hours taken by part-time personnel}))$ Formula to calculate FTE Graduate Programmes:

$(FTE = \text{full-time headcount} + (\text{part-time headcount}/(\text{full credits i.e., } 06/\text{average of credit hours taken by part-time personnel}))$

Full-time TAs

Full-time TA is a graduate from LUMS or any other HEC recognized University. A full-time TA must have a CGPA equal to or greater than 3.20. S/he can have a maximum workload of 40 hours per week. The contract for full-time Teaching Assistants is for ONE-year (renewed on semester basis) extendable to a maximum duration of TWO years.

Grade

An alphabet that indicates student's work quality and performance evaluation in a

course e.g. A+ (Exceptional) and F (Fail) etc.

Grading

The act of classifying something on a scale by quality, rank, size, or progression.

Graduate

Someone who has successfully completed the degree programme requirements and has been awarded a degree.

Graduating Senior

'A student in the final semester, enrolled in course(s) which confirms that s/he will be completing the required credit hours and graduation requirements for the respective degree programme.

Graduation

The formal process of receiving a degree, often at a graduation ceremony.

Honours and Awards

Honours and awards can be given to student(s), faculty and staff by LUMS or external party as recognition of an outstanding achievement.

Internal Grants

Sponsored research initiatives supported by LUMS

Internship

The internship is an important practical experience allowing students the opportunity to synthesize their in-class academic learning with the real-world organizational practice. Internship can be a mandatory requirement for the completion of a degree at LUMS.

Interschool transfer

A student who was initially enrolled in another School/Major at LUMS and after following the University defined process is transferred to another School/Major.

IP Rights

Intellectual Property Rights (IPR) of a researcher. IP refers to creation

promulgated by the human mind which are considered as a controllable resource and can be utilized to obtain future benefits e.g. patent, copyright, trademark etc.

Joint Major

Joint major provides the richness of two undergraduate pre-defined joint major areas in which degree programmes are offered at LUMS. In order to complete a joint major degree a student is required to complete minimum 130 credit hours.

Junior (3rd Year Student)

An undergraduate student in the third year of study at the University.

The students are categorized according to the number of credits earned during their academic career at LUMS.

Lab

An academic period defined in the class schedule devoted to work or study for Laboratory work. (Lab sessions are usually scheduled to compliment lectures and have some required experimental work. Usually, labs have a percentage of the final grade allocated to them. However, labs are also offered as a separate graded course particularly for SBASSE students).

Leave of Absence

An authorized time out from studies for reasons such as ill health, extenuating circumstances or exchange programme.

Lecture

An exposition of a given subject delivered before an audience or class, for the purpose of instruction.

Letter of Recommendation

A letter of recommendation is a document in which the writer assesses and provides the detail of the qualities, characteristics, and capabilities of the person being recommended in terms of that individual's ability to perform a particular task or function.

Loan

A monetary amount paid to a student (with or without interest) which needs to be paid back within stipulated time frame.

LUMS Smartcard ID

LUMS smartcard is the standard identification for the faculty, staff, students and alumni.

Major Core

Major core curriculum is the set of common courses which are mandatory for a student pursuing a particular major.

Major Elective

The major elective curriculum is the set of common courses which are mandatory for a student pursuing a particular major.

Major

The principal field of study of a student at LUMS.

Merit Scholarship

Merit scholarship is an award of Financial Aid to students who perform exceptionally well and maintain top position in their School as per policy and criteria defined by the University.

Midterm Exam

A midterm exam is a graded instrument near the middle of an academic semester.

Minor

Study/qualify in a subsidiary subject which could be adjacent or distinct from the major stream of study.

National Outreach Programme (NOP)

LUMS Scholarship Programme to provide the talented yet financially challenged youth of Pakistan a chance to study at LUMS on full financial aid.

National Student

A permanent resident of Pakistan whose record is registered with National Database and Registration Authority (NADRA) and does not require a visa to enter Pakistan.

Official Transcript

A transcript printed on special transcript paper with security features, provided in a sealed and stamped envelope.

Open day

A day planned for prospective students to get oriented with the university.

Orientation (O-week)

Orientation is a period of time at the beginning of the academic career at LUMS, during which a variety of planned trainings, events and activities are conducted to orient and welcome new students.

Part-time Programme

The flexibility of completing a programme of study in a longer duration than the regular time specified by the University to complete that particular programme/degree.

Applicable only, in case of students who for medical/beyond human control reasons, as verified by the University are unable to undertake full-time load.

Part-time TAs

Part-time TA is a LUMS graduate level active student or a graduate from any other HEC recognized University. The student must have a CGPA equal to or greater than 3.20. S/he can have a maximum workload of 20 hours per week. Part-time (internal) graduate TAs require an active, full-time student status.

PhD Supervisor

A Full-time faculty member, under whom the students are admitted into a PhD programme and is associated with the research area most relevant to the student's interest.

Plagiarism

Plagiarism is the use of the intellectual work of other people, without acknowledgement, and the act of representing the ideas or discoveries of another as one's own in written work submitted for assessment. Plagiarism could lead

to strict disciplinary action against the individual.

Portal

Website that can only be accessed by University students and staff and provides a range of personalized tools and information.

Pre-requisites

The requirement(s) that must be met, in order to be eligible to enroll in a course. This may include passed course(s), registration in a specific programme or plan, specified academic level or academic standing.

Primary Nationality

The first nationality attained by an individual regardless of birthplace.

Prospective student

A candidate who is interested in studying at LUMS.

Quiz

A quiz is a brief assessment used in education and similar fields to measure growth in knowledge, abilities and skills. Quizzes can be taken during any teaching session of a course for students' assessment about the topic being covered in the session and are usually a graded component of the course. Quizzes can be announced/un-announced.

RA-(Research**Assistant/Associate)**

A research assistant/associate is a researcher employed, often on a temporary contract, by LUMS for the purpose of assisting in academic research. Assistant is usually a junior level position whereas, Associate is an experienced researcher.

Recitation

Recitations are conducted to reinforce the concepts delivered in the lecture. Recitations supplement the course material, and are conducted in small groups for individualised engagement by teaching assistant (TA) or instructor.

Registrar's Office (RO)

Registrar Office (RO) is the custodian of LUMS student records and transcripts, degree progress and graduation audit, in addition to serving as a clearinghouse for course enrolment and other related activities e.g. assigning majors and swapping or changing them subsequently, posting of grades etc. RO also serves as the transparent implementer of approved University policies and functions as the secretariat to University Committees.

Research

Research can be defined as an activity involving a creative program of systematic investigation which: 1. Typically carries on for a considerable period; 2. Involves potential innovation and risk. With research, it is not possible to predict whether a given objective can be achieved; 3. Leads to publicly verifiable outcomes that are open to peer appraisal; and 4. May be initiated by a research proposal and funded by a sponsor.

SCGPA (Specialization Cumulative Grade Point Average)

Sum of all grade points divided by total credit hours attempted in the particular stream/major of study which includes major cores, major electives and relevant free electives.

Semester Withdrawal

Withdrawal of a student from the semester on his/her own will following a formal procedure.

Semester

At LUMS each semester consists of 16 weeks, comprising 15 teaching weeks including reading and review period and a final examination week.

Seminar

A group meeting in which participants and trainer/faculty discuss information on a chosen topic.

Senior (4th Year Student): An undergraduate student in the final year of university study. The

students are categorized according to the number of credits earned during their academic career at LUMS

Senior Project

Senior project (Sproj) is a collaborative task that may be taken in the senior year according to the requirements specified for a particular academic programme.

Separation (Low CGPA)

If CGPA of the student remains below 2.0 for two consecutive regular semesters (Fall and Spring), then s/he will be separated from the programme.

SGPA (Semester Grade Point Average)

Sum of all grade points divided by total credit hours attempted in a particular semester.

Sophomore (2nd Year Student)

An undergraduate student in the 2nd year of university study. The students are categorized according to the number of credits earned during their academic career at LUMS.

Student

An individual who is pursuing an undergraduate, graduate or postgraduate degree at LUMS.

Student Loans

Loans from University to help university students pay their living and study costs.

Teaching Assistant (TA)

Teaching Assistant is an active student of graduate level at the University or an externally hired alumnus/graduate. S/he provides teaching support and is responsible to grade, monitor/invigilate, lead lab(s) and/or discussion sessions, recitations and tutorials. A TA is required to work during specified office hours in order to provide assistance to the students. His/her work assignments are carried out under the close supervision of course instructor(s). Exchange, visiting or auditing

students are not eligible for this position.

Thesis

A thesis is a document submitted in support of candidature for a graduate/doctoral degree presenting the author's research.

Transcript

The transcript is an inventory of the courses taken, grades obtained, CGPA and credit hours earned by a student throughout his/her academic career.

Transfer Student

A student who was initially enrolled in another accredited institution and after following the University defined process is admitted to LUMS.

Unauthorized Withdrawal

Withdrawal of a student from the University/Semester on his/her own will but without following a formal procedure.

Undergraduate Exchange Student: Inbound

International students who study at LUMS for one/two semesters according to the terms and conditions defined for a bi-lateral exchange programme. The exchange programme must be academic in nature and acknowledged by a formal agreement through LUMS.

Undergraduate Exchange Student: Outbound

LUMS students who go abroad to study for one/two semesters according to the terms and conditions defined for a bi-lateral exchange programme. The exchange programme must be academic in nature and acknowledged by a formal agreement through LUMS. The international exchange programme must be between LUMS and a university, NOT between LUMS and a company OR corporation.

Undergraduate Student

A student pursuing a Bachelor's level or equivalent degree at

LUMS.

This includes programmes designed to provide intermediate academic and/or professional knowledge, skills and competencies leading to a first tertiary degree or equivalent qualification.

Undergraduate TA

Undergraduate TA is an active undergraduate student at LUMS, who can take a maximum workload of 20 hours per week. The minimum cumulative GPA available in Zambeel must be equal to or greater than 3.2 (Candidates having semester GPA greater than 3.2 and Cumulative GPA less than 3.2 cannot be considered for TA-ship).

An Undergraduate TA's responsibility is to provide assistance and mark minor course instruments (e.g. quizzes, MCQs, Lab reports etc.) as assigned by the course instructor and/or TA. However, s/he is not eligible to upload marks in Zambeel and invigilate examinations. S/he can sit through the class upon the discretion of course instructor and nature of the course. An undergraduate TA should not have any Disciplinary Committee decision against him/her for violation of the university rules and regulations. Exchange, visiting or auditing students are not eligible for this position.

University Academic Honours and Awards

University Academic Honours are bestowed as recognition of outstanding academic achievement and to further encourage sound scholarship. They are awarded to every undergraduate student attaining the required proficiency. For some awards, students also receive certificates.

University Core Requirements:

he core curriculum is the set of common courses required to be successfully completed by all undergraduate students irrespective of their allocated major.

University Holiday

Day(s) when Administrative and Academic Offices are closed.

University Withdrawal

Withdrawal of a student from the University on his/her own will following a formal procedure. This could be categorized as withdrawal from programme prior to or after the commencement of classes.

Unofficial Transcript

A transcript with a watermark "unofficial" and without the signature of the Registrar. It is not provided in a sealed and stamped envelope.

In case an official transcript is opened, and the seal is broken, then it should also be treated as unofficial.

VC

Vice Chancellor is the chief executive of the university for both academic and administrative affairs.

Visiting Student

A student who takes course(s) at LUMS after due University defined process on fulfilment of admission requirements.

Year Admitted

The year in which an admitted student joins the degree program. The students at LUMS joins the degree program in either of the regular semester(s) of that particular academic year i.e., Fall OR Spring. Example: The Academic Year 2017-2018 at LUMS comprises two regular semesters, the Fall 2017 & Spring 2018. If a student joins the program in Fall 2017-2018 or *Spring 2017-2018 (*only in case of transfer

students), the academic year of admission will be 2017.

Year Graduated

The year in which a student completes all the degree requirements from LUMS and is eligible to convocate. In order to mark graduation year in Zambeel, the submission of Graduation Audit Form (GAF) and inclusion of name in the faculty plenary for that particular semester is requisite.

Example: If a student completes all the degree requirements in Summer 2017, Fall 2017 or Spring 2018, the year of graduation will be marked as 2018 on the regular degree.

On the transcript, the year of graduation for the Summer Semester may vary from the degree and will be according to the date when completion has been assigned to the student. Please also refer to definition of "Degree Before Convocation".

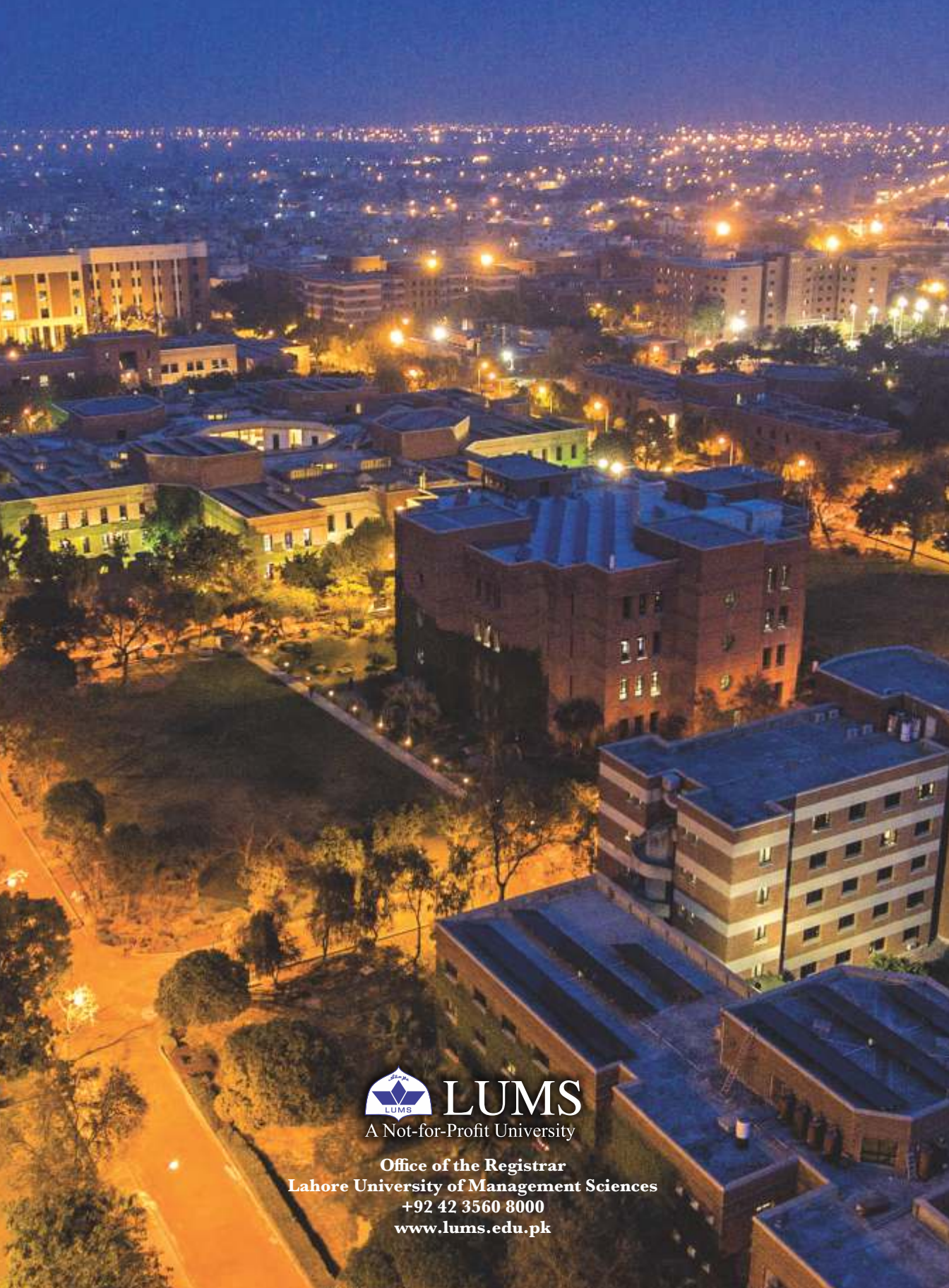

LUMS

A Not-for-Profit University

Office of the Registrar

Lahore University of Management Sciences

+92 42 3560 8000

www.lums.edu.pk